

PACKAGE DIMENSIONS

F TYPE

TABLE 1	
unit:mm	
Symbol	Dimensions
H(max.)	26.5
H1(max.)	28.0
L(min.)	20.0
L1(min.)	15.0
D(max.)	23.0
D1	7.5±0.8/10.0±1.0
T(max.)	TABLE 2
d(±0.05)	0.8/1.0
d1(±0.4)	1.4/1.6

TABLE 2			
unit:mm			
Model	T(Max.)	Model	T(Max.)
180K	4.35	361K	5.38
220K	4.44	391K	5.55
270K	4.59	431K	5.77
330K	4.80	471K	5.99
390K	4.56	511K	6.21
470K	4.77	561K	6.48
560K	5.02	621K	6.81
680K	5.32	681K	7.14
820K	4.48	751K	7.53
101K	4.65	781K	7.69
121K	4.80	821K	7.91
151K	4.52	911K	8.17
181K	4.66	102K	8.64
201K	4.76	112K	9.16
221K	4.84	122K	9.69
241K	4.95	142K	11.26
271K	5.00	162K	11.78
301K	5.05	182K	12.83
331K	5.22		

ELECTRICAL CHARACTERISTIC

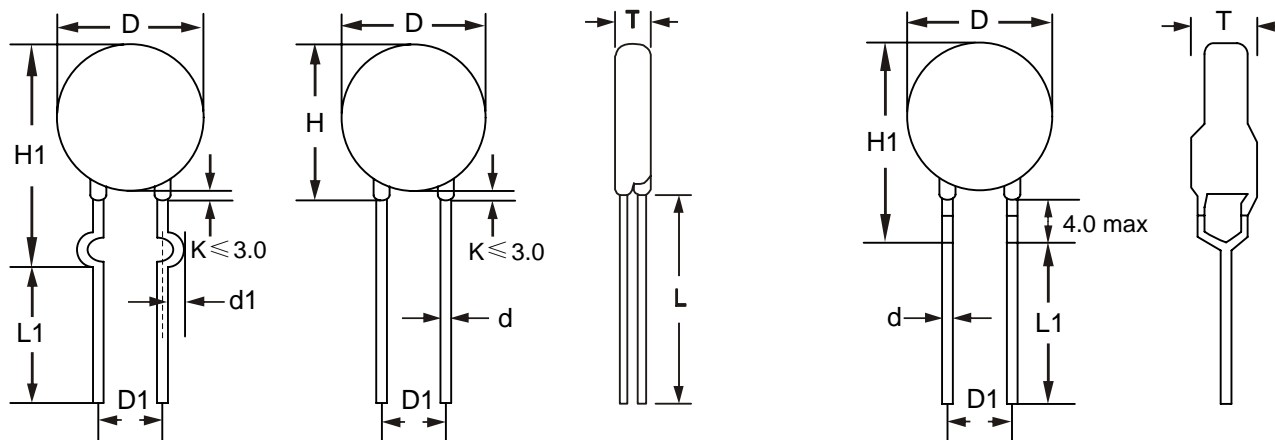
Part Number		Maximum Allowable Voltage		Varistor Voltage	Maximum Clamping Voltage		Withstanding Surge Current		Maximum Energy (10/1000μs)		Rated Power	Typical Capacitance (Reference)
Standard	High Surge	V _{AC} (V)	V _{DC} (V)	V _{1mA} (V)	I _P (A)	V _C (V)	I(A) Standard	I(A) High Surge	(J) Standard	(J) High Surge	(W)	@1KHZ(pf)
20D180K	20D180J	11	14	18(15~21.6)	20	36	2000	3000	11	13	0.2	28500
20D220K	20D220J	14	18	22(19.5~26)	20	43	2000	3000	14	16	0.2	18500
20D270K	20D270J	17	22	27(24~31)	20	53	2000	3000	16	19	0.2	13000
20D330K	20D330J	20	26	33(29.5~36.5)	20	65	2000	3000	23	24	0.2	11500
20D390K	20D390J	25	31	39(35~43)	20	77	2000	3000	26	28	0.2	8500
20D470K	20D470J	30	38	47(42~52)	20	93	2000	3000	30	34	0.2	7400
20D560K	20D560J	35	45	56(50~62)	20	110	2000	3000	41	41	0.2	6500
20D680K	20D680J	40	56	68(61~75)	20	135	2000	3000	46	49	0.2	5800
20D820K	20D820J	50	65	82(74~90)	100	135	6500	10000	38	56	1.0	4900
20D101K	20D101J	60	85	100(90~110)	100	165	6500	10000	45	70	1.0	4000
20D121K	20D121J	75	100	120(108~132)	100	200	6500	10000	55	85	1.0	3300
20D151K	20D151J	95	125	150(135~165)	100	250	6500	10000	70	106	1.0	2700
20D181K	20D181J	115	150	180(162~198)	100	300	6500	10000	85	130	1.0	2200
20D201K	20D201J	130	170	200(180~220)	100	340	6500	10000	95	140	1.0	2000
20D221K	20D221J	140	180	220(198~242)	100	360	6500	10000	100	155	1.0	1800
20D241K	20D241J	150	200	240(216~264)	100	395	6500	10000	108	168	1.0	1650
20D271K	20D271J	175	225	270(243~297)	100	455	6500	10000	127	190	1.0	1500
20D301K	20D301J	190	250	300(270~330)	100	500	6500	10000	136	210	1.0	1300
20D331K	20D331J	210	275	330(297~363)	100	550	6500	10000	150	228	1.0	1200
20D361K	20D361J	230	300	360(324~396)	100	595	6500	10000	163	255	1.0	1100
20D391K	20D391J	250	320	390(351~429)	100	650	6500	10000	180	275	1.0	1000
20D431K	20D431J	275	350	430(387~473)	100	710	6500	10000	190	305	1.0	930
20D471K	20D471J	300	385	470(423~517)	100	775	6500	10000	220	350	1.0	850
20D511K	20D511J	320	415	510(459~561)	100	845	6500	10000	220	360	1.0	780
20D561K	20D561J	350	460	560(504~616)	100	925	6500	10000	220	380	1.0	710
20D621K	20D621J	385	505	620(558~682)	100	1025	6500	10000	220	390	1.0	650
20D681K	20D681J	420	560	680(612~748)	100	1120	6500	10000	230	400	1.0	600
20D751K	20D751J	460	615	750(675~825)	100	1240	6500	10000	255	420	1.0	530
20D781K	20D781J	485	640	780(702~858)	100	1290	6500	10000	265	440	1.0	510
20D821K	20D821J	510	670	820(738~902)	100	1355	6500	10000	282	460	1.0	500
20D911K	20D911J	550	745	910(819~1001)	100	1500	6500	10000	310	510	1.0	440
20D102K	20D102J	625	825	1000(900~1100)	100	1650	6500	10000	342	565	1.0	400
20D112K	20D112J	680	895	1100(990~1210)	100	1815	6500	10000	383	620	1.0	360
20D122K	20D122J	750	990	1200(1080~1320)	100	1980	6500	10000	408	660	1.0	350
20D142 K	20D142J	880	1140	1400(1260~1540)	100	2310	6500	10000	532	784	1.0	340
20D162K	20D162J	1000	1280	1600(1440~1760)	100	2640	6500	10000	606	896	1.0	330
20D182K	20D182J	1100	1465	1800(1620~1980)	100	2970	6500	10000	625	990	1.0	320

The tolerance of varistor voltage between 18V and 27V is more than 10%.

Varistor voltage ≥ 1200V, structure diagram is F type.

ELECTRICAL RATINGS

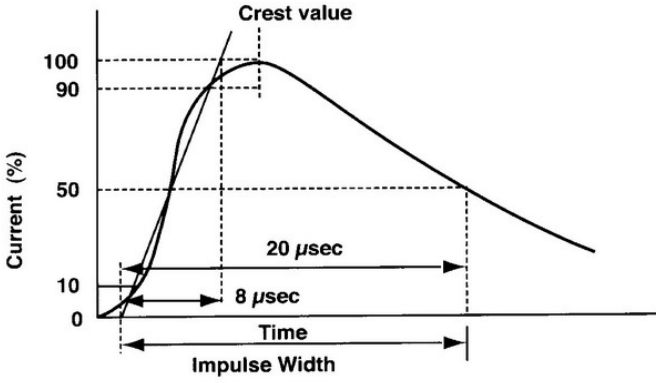
Item	Test Condition/Description	Requirement																									
Varistor Voltage	The voltage between two terminals with the specified measuring current 1mA.DC applied is call Vb.																										
Maximum Allowable Voltage	The recommended maximum sine wave voltage (RMS) or the maximum DC voltage can be applied continuously.																										
Maximum Clamping Voltage	<p>The maximum voltage between two terminals with the specification standard impulse current. Applied waveform: 8/20μsec.</p> 		To meet the specified value																								
Rated Wattage	The maximum average power that can be applied within the specified ambient temperature.																										
Energy	The maximum energy within the varistor voltage change of ±10% when one impulse of 10/1000μsec. or 2 msec. is applied.																										
Withstanding Surge Current	The maximum current within the varistor voltage change of ±10% with the standard impulse current (8/20μsec.) applied one time.																										
Varistor Voltage Temp. Coefficient	$\frac{V_b \text{ at } 20^\circ\text{C} - V_b \text{ at } 70^\circ\text{C}}{V_b \text{ at } 20^\circ\text{C}} \times \frac{1}{50} \times 100 (\% / ^\circ\text{C})$	0.05% / °C max																									
Surge Life	<p>The change of Vb shall be measured after the impulse listed below is applied 10,000 times continuously with the interval of ten seconds at room temperature.</p> <table border="1" data-bbox="395 1451 1244 1975"> <tbody> <tr> <td rowspan="2">5Φ series</td> <td>180K to 680K</td> <td>10A (8/20μsec.)</td> </tr> <tr> <td>820K to 751K</td> <td>20A (8/20μsec.)</td> </tr> <tr> <td rowspan="2">7Φ series</td> <td>180K to 680K</td> <td>25A (8/20μsec.)</td> </tr> <tr> <td>820K to 821K</td> <td>50A (8/20μsec.)</td> </tr> <tr> <td rowspan="2">10Φ series</td> <td>180K to 680K</td> <td>50A (8/20μsec.)</td> </tr> <tr> <td>820K to 112K</td> <td>100A (8/20μsec.)</td> </tr> <tr> <td rowspan="2">14Φ series</td> <td>180K to 680K</td> <td>75A (8/20μsec.)</td> </tr> <tr> <td>820K to 182K</td> <td>150A (8/20μsec.)</td> </tr> <tr> <td rowspan="2">20Φ series</td> <td>180K to 680K</td> <td>100A (8/20μsec.)</td> </tr> <tr> <td>820K to 182K</td> <td>200A (8/20μsec.)</td> </tr> </tbody> </table>	5Φ series	180K to 680K	10A (8/20μsec.)	820K to 751K	20A (8/20μsec.)	7Φ series	180K to 680K	25A (8/20μsec.)	820K to 821K	50A (8/20μsec.)	10Φ series	180K to 680K	50A (8/20μsec.)	820K to 112K	100A (8/20μsec.)	14Φ series	180K to 680K	75A (8/20μsec.)	820K to 182K	150A (8/20μsec.)	20Φ series	180K to 680K	100A (8/20μsec.)	820K to 182K	200A (8/20μsec.)	$\frac{\Delta V_b}{V_b} \leq \pm 10\%$
5Φ series	180K to 680K		10A (8/20μsec.)																								
	820K to 751K	20A (8/20μsec.)																									
7Φ series	180K to 680K	25A (8/20μsec.)																									
	820K to 821K	50A (8/20μsec.)																									
10Φ series	180K to 680K	50A (8/20μsec.)																									
	820K to 112K	100A (8/20μsec.)																									
14Φ series	180K to 680K	75A (8/20μsec.)																									
	820K to 182K	150A (8/20μsec.)																									
20Φ series	180K to 680K	100A (8/20μsec.)																									
	820K to 182K	200A (8/20μsec.)																									

MARKING CODE

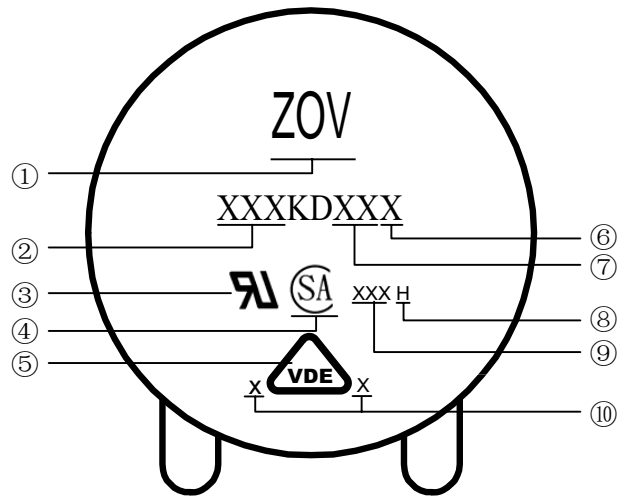

- ① ZOV Logo
- ② Varistor Voltage
- ③ UL Accreditation Logo
- ④ CSA Accreditation Logo
- ⑤ VDE Accreditation Logo
- ⑥ "J" is High Surge Code,not "J" is Standard Surge
- ⑦ Disk Size
- ⑧ "H" is Halogen Free Code,not "H" is Halogen
- ⑨ Date Code
- ⑩ Product Line Code