

# Service Manual

Dolby NR-Equipped  
Stereo Cassette Deck

Cassette Deck  
**RS-B655**

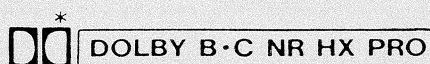

Color

(K)... Black Type



Area

Country Code	Area	Color
(E, E5)	Continental Europe.	(K)
(EB)	Great Britain.	
(EG)	F.R. Germany and Italy	

\* HX Pro headroom extension originated by Bang Olufsen and manufactured under license from Dolby Laboratories Licensing Corporation. "DOLBY", the double-D symbol, and "HX PRO" are trademarks of Dolby Laboratories Licensing Corporation.

## MECHANISM SERIES: AR350

## SPECIFICATIONS

### CASSETTE DECK SECTION

Deck system	Stereo cassette deck
Track system	4-track, 2-channel
Heads	
Rec/play	Permalloy head
Erasing	Double-gap ferrite head
Motors	
Capstan	Quartz direct drive DC motor
Reel table drive	DC motor
Recording system	AC bias
Bias frequency	80 kHz
Erasing system	AC erase
Tape speed	4.8 cm/sec. (1 $\frac{7}{8}$ ips)
Frequency response	
NORMAL	20 Hz~18 kHz
CrO <sub>2</sub>	20 Hz~16 kHz (DIN)
METAL	20 Hz~18 kHz
METAL	20 Hz~17 kHz (DIN)
METAL	20 Hz~19 kHz
METAL	20 Hz~18 kHz (DIN)
S/N (signal level=max recording level, CrO <sub>2</sub> : type tape)	
Dolby C NR on	74 dB (CCIR)
Dolby B NR on	66 dB (CCIR)
Dolby NR off	56 dB (A weighted)

Wow and flutter 0.05% (WRMS)  
±0.15% (DIN)

### Fast forward and rewind times

Approx. 90 seconds with C-60 cassette tape

### Input sensitivity and impedance

MIC 0.25 mV/400Ω~10 kΩ  
LINE 60 mV/47 kΩ

### Output voltage and impedance

LINE 400 mV/800Ω  
HEADPHONES 125 mV/8Ω  
(8Ω~600Ω)

### GENERAL

Power consumption 21 W

### Power supply

For Great Britain AC 240V, 50/60Hz  
For others AC 220V, 50/60Hz

### Dimensions (W × H × D)

430 × 135 × 290 mm  
(16 $\frac{15}{16}$ " × 5 $\frac{1}{8}$ " × 11 $\frac{13}{32}$ " )

### Weight

4.9 kg (10.8 lb.)

### Note:

Specifications are subject to change without notice.  
Weight and dimensions are approximate.

# Technics

Matsushita Electric Industrial Co., Ltd.

Central P.O. Box 288, Osaka 530-91, Japan

CONTENTS

CONNECTIONS .....	Page
ACCESSORIES .....	2
FRONT PANEL CONTROLS AND FUNCTIONS .....	3, 4
RECORDING WITH HIGH TONE QUALITY .....	5
OUTLINE OF THE DIRECT DRIVE MOTOR SYSTEM .....	6
DISASSEMBLY INSTRUCTIONS.....	7~10
MEASUREMENT AND ADJUSTMENT METHODS.....	11~13
TERMINAL FUNCTION OF IC'S.....	14, 15
BLOCK DIAGRAM.....	16, 17
INTERNAL CONNECTION OF FL.....	18
SCHEMATIC DIAGRAM.....	19~26

TRUBLESHOOTING OF DIRECT DRIVE MOTOR.....	Page
TERMINAL GUIDE OF IC'S,	26
TRANSISTORS AND DIODES.....	27
PRINTED CIRCUIT BOARDS.....	28~32
WIRING CONNECTION DIAGRAM .....	33
REPLACEMENT PARTS LIST.....	34~36
EXPLODED VIEWS.....	37~40
REPLACEMENT PARTS LIST.....	41
RESISTORS & CAPACITORS.....	42~44
PACKING.....	44

TECHNICAL INFORMATION

※ This technical information is located on pp 45-51 of the RS-B555 Service Manual (Order No. AD8907231C5). Therefore, refer to that Service Manual.

CONNECTIONS

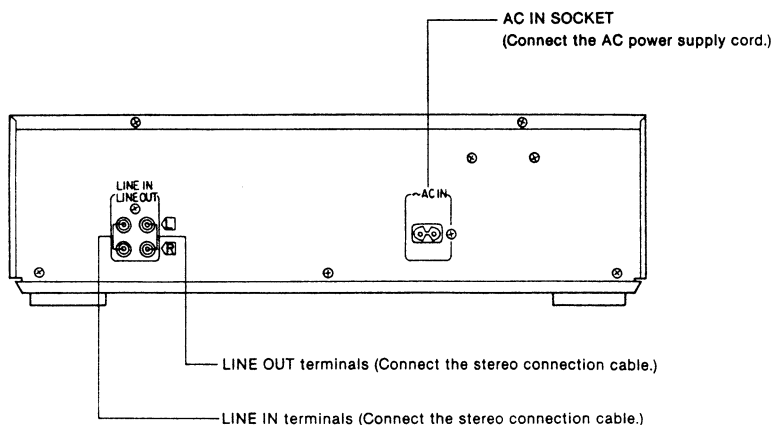

ACCESSORIES

• Stereo connection cables..... 2  
[SJP2249-3]

• AC power supply cord..... 1  
[SFDAC05E03: (E, E5, EG)]  
[SJA193-1: (EB)]

FRONT PANEL CONTROLS AND FUNCTIONS

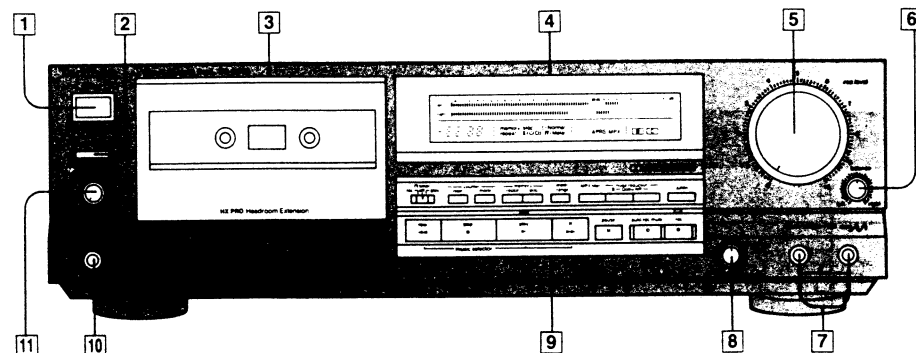

- 1 Power "standby  $\downarrow$  /on" switch (power "standby  $\downarrow$  /on")**  
This switch switches ON and OFF the secondary circuit power only. The unit is in the "standby" condition when this switch is set to the "standby( $\downarrow$ )" position. Regardless of the switch setting, the primary circuit is always "live" as long as the power cord is connected to an electrical outlet.
- 2 Eject button ( $\blacktriangle$ eject)**  
This button can be used to open the cassette holder.
- 3 Cassette holder**
- 4 Display section**
- 5 Recording-level control (rec level)**  
This control can be used to regulate the recording level and the peak level.
- 6 Recording-balance control (balance)**  
Use this control to balance the left and right sound levels during recording.
- 7 Microphone jacks (mic)**
- 8 Bias-adjustment control (bias adjust)**  
The frequency response for each tape type can be equalized by using this control.
- 9 Operation section**
- 10 Headphones jack (phones)**
- 11 Headphones volume control (phones level)**

Display Section

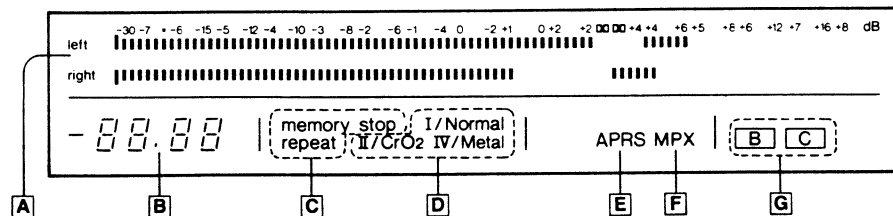

- A Input level meter (peak level)**  
During playback, this meter indicates the level of the recorded sound. During recording, it indicates the level being recorded, adjusted by the recording-level control.
- B Tape/Linear counter**  
Indicates the amount of tape movement or elapsed time.
- C Memory-mode indicators (memory stop/repeat)**  
Each indicator illuminates to show which of the memory mode was set by the memory-mode buttons.
- D Tape-select indicators**  
The type of tape being used will be automatically detected and the indicator will illuminate.

**E** **APRS indicator (APRS)**

Illuminates to indicate that the "APRS" is set to "on" in the recording stand-by mode.

**F** **Multiplex filter indicator (MPX)**

Illuminates to indicate that the multiplex filter is set to "on".

**G** **Dolby noise-reduction indicators (B, C)**

Each indicator illuminates to show the type of Dolby noise-reduction system selected by pressing one of the Dolby noise-reduction buttons.

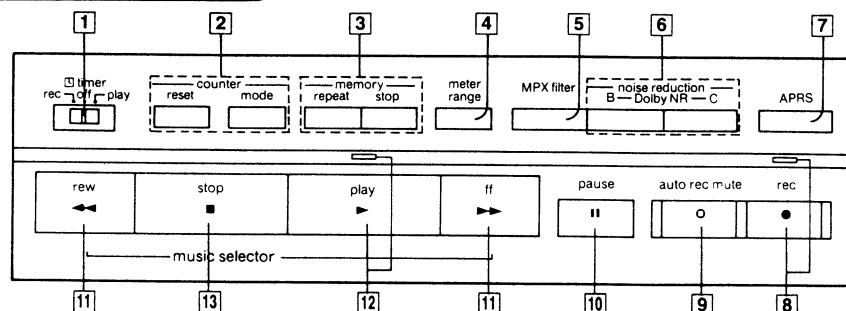
**1** **Timer switch (timer)**

This switch is used to automatically begin a tape recording or tape playback at a certain time, selected by a timer (not included).

**2** **Counter buttons (counter reset/mode)**

**mode:** This button can be used to select the tape/linear counter indication.

**reset:** This button can be used to reset the tape/linear counter indication to "0000".

**3** **Memory-mode buttons (memory repeat/stop)**

**stop:** This button can be used to rewind the tape to the preset "0000" point when the rewind (rew) button is pressed.

**repeat:** This button can be used to set this unit to the "A-B repeat" mode.

**4** **Meter-range selector (meter range)**

This selector can be used to select the meter-range display of the input level meter.

**5** **Multiplex filter switch (MPX filter)**

This switch can be used during the recording of an FM stereo broadcast that employs Dolby noise reduction so as to prevent misoperation of the Dolby noise reduction.

**6** **Dolby noise-reduction buttons (noise reduction)**

These buttons are used to reduce the hissing noise heard from the tape. This unit is provided with both the B-type and C-type noise-reduction systems.

**7** **APRS button (APRS)**

This button can be used to hold the peak level while monitoring the input sound.

The "APRS" can only be used in the recording stand-by mode.

**8** **Record button and indicator (rec)**

This button can be used to change the tape deck to the recording stand-by mode.

This indicator illuminates to indicate that this tape deck is in the recording stand-by mode, or is recording.

**9** **Automatic-record-muting button (auto rec mute)**

This button can be used to make a silent interval on the tape being recorded on tape deck.

**10** **Pause button (pause)**

This button can be used to temporarily stop the tape playback or recording of tape deck.

**11** **Rewind/fast-forward/search buttons (rew/ff)**

These buttons can be used to fast forward or rewind the tape, or to easily search for the tune's beginning of the tape quickly.

**12** **Playback button and indicator (play)**

This button can be used to start the playback or recording of the cassette.

(The tape will then begin moving in the left-to-right direction.)

When this indicator illuminates steadily, it indicates that this tape deck is in the playback mode or the recording mode. When it flashes continually, this is an indication that this tape deck is in the pause mode or the recording stand-by mode.

**13** **Stop button (stop)**

This button can be used to stop tape movement.

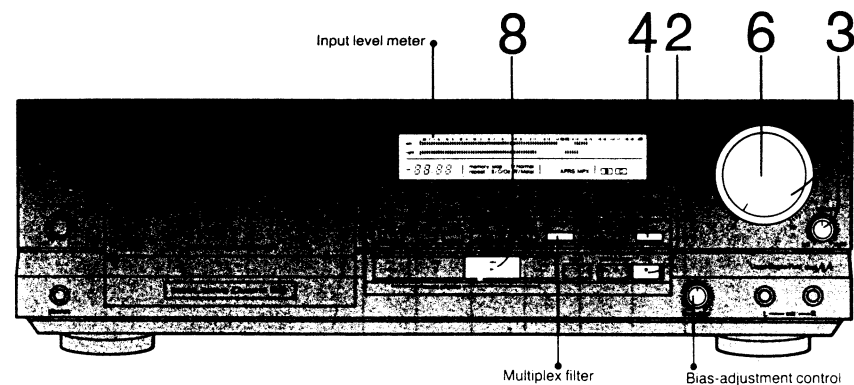
**RECORDING WITH HIGH TONE QUALITY****APRS function**

Because the dynamic range of cassette tape is narrower than the dynamic range of a digital source, the recording will be too noisy if the recording level setting is too low, and, conversely, the recorded sound will be distorted if the setting is too high.

It was for this reason that it has always been recommended that the signals to be recorded be first (before recording) input to the cassette deck and the recording level then be set while watching the level meter, but, for former conventional level meter equipped with the peak-hold function, it was necessary to re-adjust and input the signals again if the level setting was too high or too low.

This unit, however, is equipped with the **APRS: Advanced Precise Recording-level System**, which holds and displays the maximum peak of the input signal level, so that once the peak level of the source is held, there is no necessity to re-input the source signals, and the optimum recording level can be set.

•The APRS function can be used only during the recording-standby mode.

**1** **Prepare for recording as described in steps 1 to 6 of the "Recording" section.****2** **Press the record button.**

(The recording indicator will illuminate and the playback indicator will flash continuously; the unit will be in the recording stand-by mode.)

**3** **Set the recording-level control and the recording-balance control to the suitable position for the sound source.****4** **Press the APRS button.**

(The APRS indicator will illuminate.)

**5** **Play the sound source to be recorded, from beginning to end.**

[The peak level (the highest level of the input signal) of the sound source will be displayed and held on the input-level meter.]

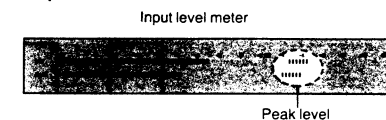
**Note:**

The range within which the peak level can be held is  $-8$  dB to  $+16$  dB. Note that the APRS indicator will flash continuously if the peak level of the sound source is input at a level that exceeds the maximum recording level ( $+16$  dB). If that happens, press the APRS button to cancel the APRS function, and then reset the recording level and set the APRS once again. Also note that the peak level cannot be held to less than  $-8$  dB.

**6** **Using the recording-level control, adjust the peak level to the desired setting.**

The peak level will move to the right when the recording-level control is turned to the right, and will move to the left when the recording-level control is turned to the left.

•The recording-balance control cannot be used to adjust the peak level.

**7** **Begin playing the sound source from the beginning once again.****8** **Press the playback button.**

(The playback indicator will illuminate steadily, and the recording will begin.)

The APRS indicator will switch OFF, and the indication of the input-level meter will return to the ordinary peak-hold mode.

## OUTLINE OF THE DIRECT DRIVE MOTOR SYSTEM

The capstan motor is actuated by the DD motor digital servo system. The FG pulse is generated after the detection of the zero crosspoint, and the reference signal generated from the quartz oscillator is compared with this FG pulse. From this comparison, the accelerated and reduced speed pulses are generated, causing the driving coil to function.

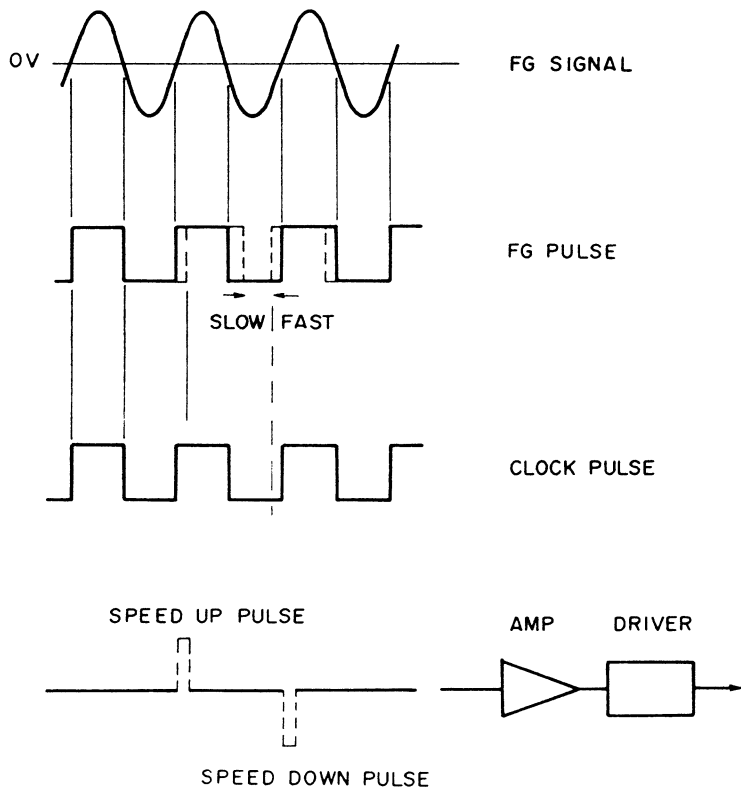

## DISASSEMBLY INSTRUCTIONS

### "ATTENTION SERVICER"

Some chassis components may have sharp edges. Be careful when disassembling and servicing.

Ref. No. 1	Removal of the cabinet	Ref. No. 2	Removal of the main P.C.B.
Procedure 1	<p>• Remove the 6 screws (1~6).</p>	<p>Procedure 1→2</p> <ol style="list-style-type: none"> <li>1. Remove the 7 screws (1~7).</li> <li>2. Remove the rear panel from the projection of the bottom chassis.</li> </ol>	
	<ol style="list-style-type: none"> <li>3. Remove the 6 screws (8~13).</li> <li>4. Remove the 1 connector (CP2).</li> <li>5. Remove the 4 flat cables (CN3, CN4, CN6, CN201).</li> <li>6. Remove the main P.C.B. in the direction of the arrow.</li> </ol> <p><b>How to remove the flat cable</b></p> <ul style="list-style-type: none"> <li>• Pull out the flat cable while pressing the connector.</li> </ul> <ol style="list-style-type: none"> <li>1. Lift the connector.</li> <li>2. Pull out the flat cable.</li> </ol>	<p><b>How to check the main P.C.B.</b></p> <ul style="list-style-type: none"> <li>• When checking the soldered surfaces of main P.C.B. and replacing the parts, do as show.</li> </ul> <ol style="list-style-type: none"> <li>1. Remove the 9 screws (1, 9, 7~8) in above figure.</li> <li>2. Remove the 4 screws (10~13).</li> <li>3. Remove the front panel in the direction of the arrow A.</li> </ol> <ol style="list-style-type: none"> <li>4. Remove the bottom board in the direction of the arrow B.</li> <li>5. Reinstall the front panel to the main P.C.B.</li> </ol>	

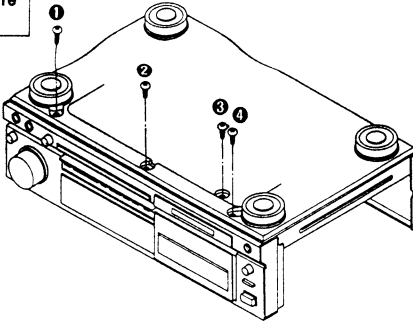
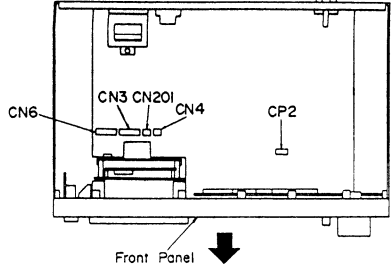
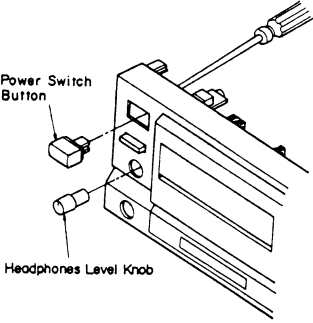
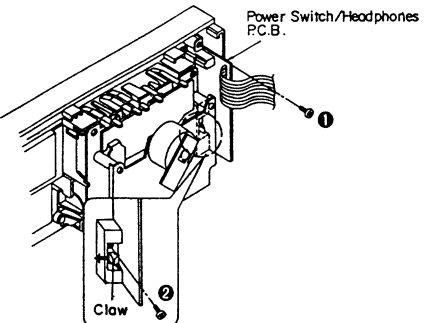
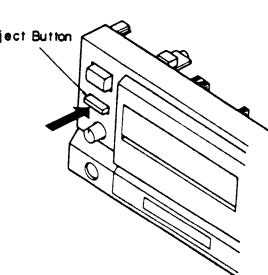
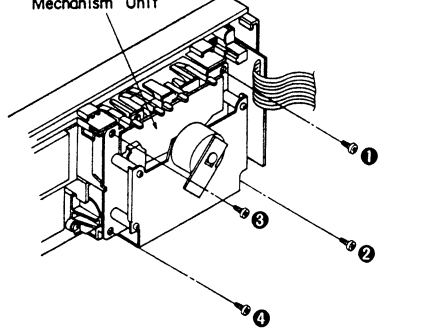

Ref. No. 3	Removal of the front panel	<ol style="list-style-type: none"> <li>Remove the 1 connector (CP2).</li> <li>Remove the 1 connector (CP2).</li> <li>Remove the 4 flat cables (CN3, CN4, CN6, CN201).</li> </ol>
Procedure 1→3		 <p>Front Panel</p> <ol style="list-style-type: none"> <li>Remove the front panel in the direction of the arrow.</li> </ol>
Ref. No. 4	Removal of the power switch/headphones P.C.B.	
Procedure 1→3→4		
Ref. No. 5	Removal of the mechanism unit	
Procedure 1→3→5		

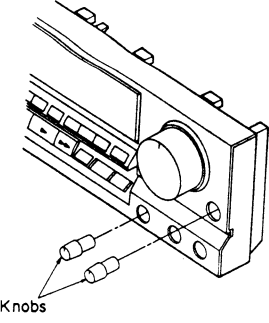
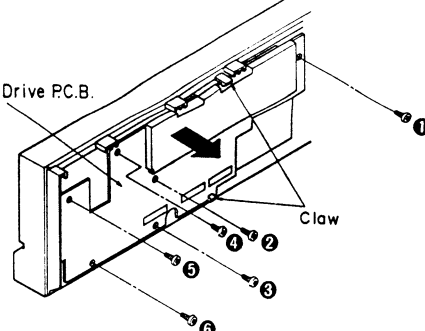
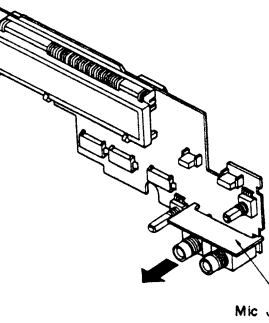
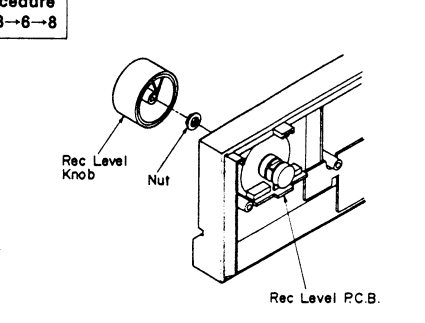
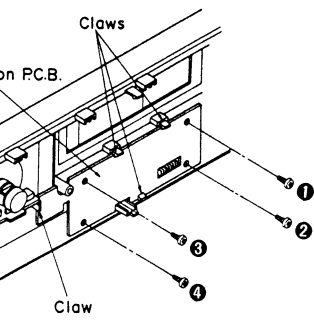
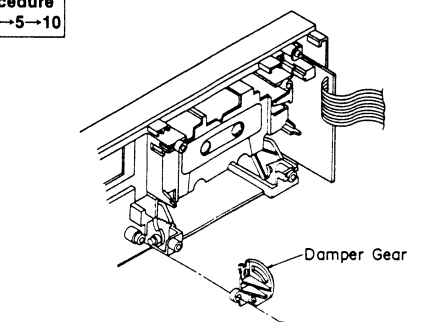
Ref. No. 6	Removal of the FL drive P.C.B.	
Procedure 1→3→6		
Ref. No. 7	Removal of the mic jack P.C.B.	Ref. No. 8
Procedure 1→3→6→7		
Ref. No. 9	Removal of the operation P.C.B.	Ref. No. 10
Procedure 1→3→6→9		

<b>Ref. No.</b> 11	<b>Removal of the cassette holder</b>	<ol style="list-style-type: none"> <li>1. Remove the rib in the direction of the arrow.</li> <li>2. Remove the cassette holder spring.</li> <li>3. Pull out the cassette holder in the direction of the arrow.</li> </ol>
<b>Procedure</b> 10→11		

<b>Ref. No.</b> 12	<b>Removal of the eject lever and eject button</b>	<ol style="list-style-type: none"> <li>1. Push the claw in the direction of the arrow A.</li> <li>2. Remove the eject lever in the direction of the arrow B.</li> <li>3. Pull out the eject button.</li> </ol>
<b>Procedure</b> 1→3→4→5→12		

## MEASUREMENT AND ADJUSTMENT METHODES

### Measurement Condition

- Rec. level control; Maximum
- Timer switch; Off
- MPX filter switch: off
- Bias-adjustment VR: Center

- Dolby NR switch; Off
- Make sure heads are clean
- Make sure capstan and pressure roller are clean
- Judgeable room temperature 20±5°C (68±9°F)

### Measuring Instrument

- EVM (Electronic Voltmeter)
- Oscilloscope
- Digital frequency counter
- AF oscillator

- ATT (Attenuator)
- DC voltmeter
- Resistor (600Ω)

### Test tape

- Head azimuth adjustment (8kHz, -20dB); QZZCFM
- Tape speed adjustment (3kHz, -10dB); QZZCWAT
- Playback frequency response (315Hz, 12.5kHz, 10kHz, 8kHz, 4kHz, 1kHz, 250Hz, 125Hz, 63Hz, -20dB); QZZCFM

- Playback gain adjustment (315Hz, 0dB); QZZCFM
- Overall frequency response, Overall gain adjustment Normal reference blank tape; QZZCRA CrO<sub>2</sub> reference blank tape; QZZCRX Metal reference blank tape; QZZCRZ

### Adjustment Points

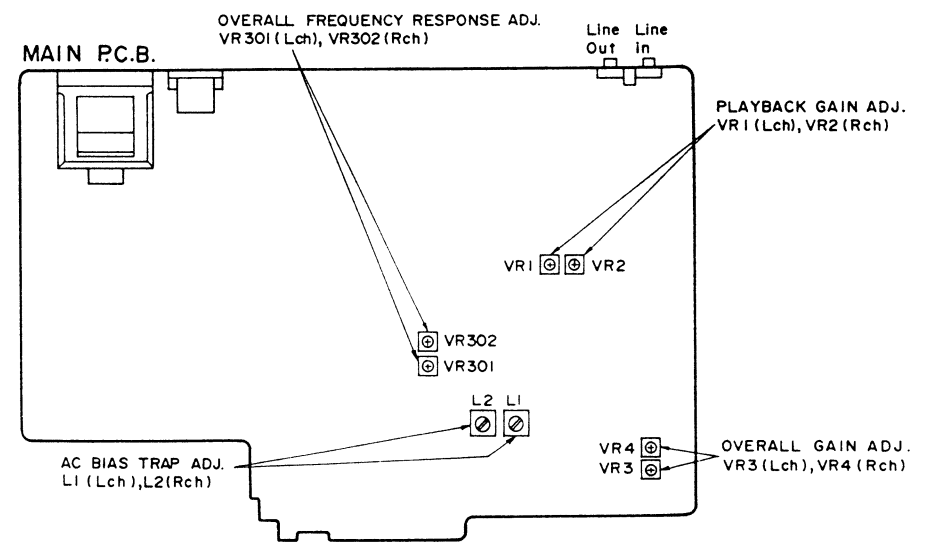

**HEAD AZIMUTH ADJUSTMENT**

1. Playback the azimuth adjustment portion (8 kHz, -20 dB) of the test tape (QZZCFM). Vary the azimuth adjusting screw until the outputs of the L-CH and R-CH are maximized and the lissajous waveform, as illustrated, approaches 0 degrees.

**Note:** If L-CH and R-CH are not maximized at the same point, adjust to the point where the levels of each channel are maximized and equal.

2. Perform the same adjustment in the play mode.
3. After the adjustment, apply screwlock to the azimuth adjusting screw.

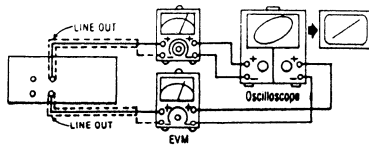

Fig. 1

Record/Playback Head



Fig. 2

**PLAYBACK GAIN ADJUSTMENT**

1. Playback the gain adjusted portion (315 Hz, 0 dB) of the test tape (QZZCFM).
2. Adjust VR1 (L-CH) and VR2 (R-CH) so that the output is within the standard value.

Standard value: 0.4V ± 0.5dB

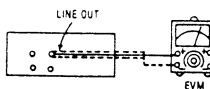

Fig. 3

**PLAYBACK FREQUENCY RESPONSE**

1. Playback the frequency response portion (315 Hz, 12.5 kHz ~ 63 Hz, -20 dB) of the test tape (QZZCFM).
2. Assure that the frequency response is within the range shown in Fig. 6 for both L-CH and R-CH.

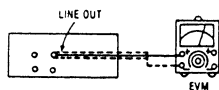

Fig. 4

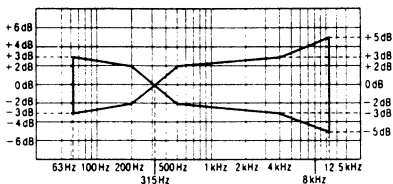
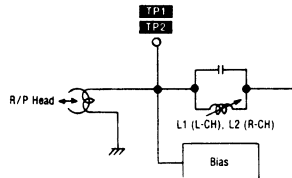

Fig. 5

**AC BIAS TRAP ADJUSTMENT**

1. Insert the Metal blank test tape (QZZCRZ) and set the unit to the Record mode.
2. Adjust L1 (L-CH) [[L2 (R-CH)]] so that the output voltage between TP1 (TP2) and GND is less than the minimum value.



**OVERALL FREQUENCY RESPONSE**

1. Insert the normal blank test tape (QZZCRA) and set the unit to the record pause mode.
2. Apply a reference input signal (1 kHz, -24 dB) through an attenuator.
3. Attenuate the signal by 20dB and adjust the frequency from 50 Hz ~ 10 kHz.
4. Record the frequency sweep.
5. Playback the recorded signal and assure that it is within the range shown in Fig. 8 in comparison to the reference frequency (1 kHz).
6. If it is not within the standard range, adjust VR301 (L-CH) and VR302 (R-CH) so that the frequency level is within the standard range.
  - Level up in high frequency range .....Increase the bias current.
  - Level down in high frequency range ...Decrease the bias current.
7. Repeat steps 2~6 above using the CrO<sub>2</sub> tape (QZZCRX) and the metal tape (QZZCRZ) increasing the frequency range to 12.5 kHz (50 Hz ~ 12.5 kHz).
8. Assure that the level is within the range shown in Fig. 9.

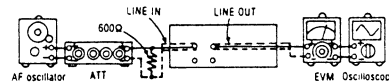

Fig. 10

**Normal Overall frequency response chart (NR OUT)**

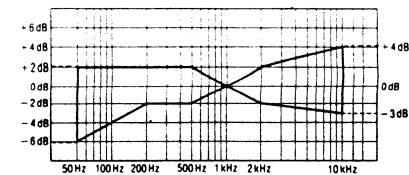

Fig. 8

**CrO<sub>2</sub> Metal Overall frequency response chart (NR OUT)**

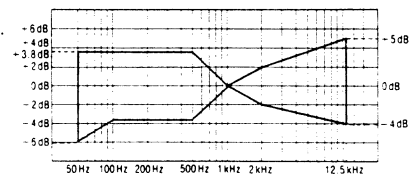

Fig. 9

**OVERALL GAIN ADJUSTMENT**

1. Insert the normal blank test tape (QZZCRA) and set the unit to the record pause mode.
2. Apply a reference input signal (1 kHz, -24 dB). Attenuate the output so that its level becomes 0.4 V.
3. Record this input signal.
4. Playback the signal recorded in step 3 above, and assure that the output is within the standard value.
5. If it is not within the standard value, adjust VR3 (L-CH) and VR4 (R-CH).
6. Repeat the step 2~5 above until the output is within the standard value.

Standard value: 0.4V ± 0.5dB

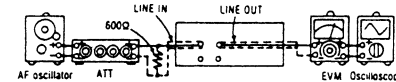

Fig. 11

## TERMINAL FUNCTION OF IC'S

### • IC901 (MB88511-224N): MICROCOMPUTER (This microcomputer is used for mechanical operation.)

Pin No.	Mark	I/O Division	Function	Pin No.	Mark	I/O Division	Function
1	DMT	O	Line out mute signal ("H"...ON, "L"...OFF)	22	DIRECT	I	CD direct operation det. signal
2	RMT	O	REC AMP mute signal ("H"...ON, "L"...OFF)			O	CD direct/LINE input select control signal ("H"...CD DIRECT, "L"...LINE INPUT)
3	BOS	O	BIAS OSC ON/OFF control signal ("H"...OFF, "L"...ON)	23	C	O	Dolby NR mode select signal NR OFF   Dolby B   Dolby C   dbx C   H   H   L   L B   H   L   H   L
4	REC	O	REC LED ON/OFF control signal ("H"...OFF, "L"...ON)	24	B		
5	PLAY	O	PLAY LED ON/OFF control signal ("H"...OFF, "L"...ON)	25	MPX	O	MPX coil ON/OFF control signal ("H"...MPX OFF, "L"...MPX ON)
6	EJECT F	O	Power eject motor open control signal ("H"...OPEN, "L"...CLOSE/STOP)	26	T/S	I	Two head/Three head select signal ("H"...THREE HEAD, "L"...TWO HEAD)
7	EJECT R	O	Power eject motor close control signal ("H"...CLOSE, "L"...OPEN/STOP)			O	Tape/Source monitor select control ("H"...TAPE MONITOR, "L"...SOURCE MONITOR)
8	CAPM	O	Capstan motor ON/OFF control signal ("H"...OFF (POWER OFF or ABNORMAL CONDITION), "L"...ON)	27	HALF	I	Cassette half det. SW terminal ("L"...ON)
9	SOL1	O	Trigger solenoid ON/OFF control signal ("H"...OFF, "L"...ON)	28	MODE	I	Mechanism mode SW terminal
10	SOL2	O	Brake solenoid ON/OFF control signal ("H"...OFF, "L"...ON)	29	ARM	I	Auto Rec Mute key signal ("L"...PUSH)
11	SOL2C	O	Brake solenoid hold ON/OFF control signal ("H"...OFF, "L"...ON (FF/REW/MS))	30	AVss	—	Connected to GND
12	RP (REEL PULSE)	I	Reel pulse signal	31	AVR	—	Connected to GND
13	RMR	O	Reel motor reverse control signal ("H"...REW, "L"...STOP/PLAY/FF)	32	AVcc	—	Power supply terminal
14	RMF	O	Reel motor forward control signal ("H"...FF/PLAY, "L"...STOP/REW)	33	KEY 1	I	Key SW Input (STOP/FF REW/PLAY/REC/PAUSE/dbx/C/B/MPX/TIMER REC/TIMER PLAY)
15	OSC	I	Single capstan/Dual capstan select signal ("H"...DUAL CAPSTAN, "L"...SINGLE CAPSTAN)	34	KEY 2	I	Key SW Input (MEMORY REPEAT/MEMORY STOP/EJECT/MONITOR/CD DIRECT/OSC/TEST/REMOTE A/B)
		O	Calibration OSC circuit ON/OFF control signal ("H"...OFF, "L"...ON)	35	ATS	I	Auto Tape Select SW Input (ATSC/ATSM/EJECT OPEN LEAF SW)
16	Ex	I	Clock OSC terminal (6MHz)	36	INH	I	REC INH SW Input (REC INH/EJECT MOTOR LEAF SW)
17	X	O					
18	RES	I	Reset signal ("L"...RESET)	37	B555	I	Connected to GND
19	OSCF	O	Calibration OSC circuit (400 Hz/10 kHz) select signal ("H"...HIGH FREQ. (10 kHz), "L"...LOW FREQ. (400 Hz))	38	DISP	O	Serial data signal of FL display (ACTIVE: "H")
20	POF	I	AC POWER detect signal	39	MSP	I	Music select det. signal ("H"...NO SIGNAL, "L"...ON SIGNAL)
21	Vss	—	GND	40	MEMORY PULSE	I	Memory Pulse signal
				41	REMOCON	I	Remote control serial data ("L" for 50ms. with counter "0000")
				42	Vcc	—	Power supply terminal

### • IC551 (HD404302SA07): MICROCOMPUTER (This microcomputer is used for FL meter operation.)

Pin No.	Mark	I/O Division	Function	Pin No.	Mark	I/O Division	Function
1	S5	O	Segment signal for FL display	22	AVcc	—	Power supply terminal
2	S6	O		23	VR IN	I	Rec level control (VR MAX...+5V)
3	S7	O		24	F IN	I	Function key terminal (COUNTER RESET/COUNTER MODE/APRS)
4	Vdisp	—	Pull down power supply terminal (-Vcc)	25	SIG L	I	LCH level signal
5	S8	O	Segment signal for FL display	26	SIG R	I	RCH level signal
6	S9	O		27	AVss	—	Connected to GND
7	S10	O		28	RESET	I	Reset terminal (with Reset: "H")
8	S11	O		29	TEST	I	Test terminal
9	S12	O		30	OSC 1	O	Clock OSC terminal (4MHz)
10	S13	O		31	OSC 2	I	
11	S14	O		32	Vcc	I	Power supply terminal
12	S15	O		33	G1	O	Grid signal for FL display
13	S16	O		34	G2	O	
14	S17	O		35	G3	O	
15	S18	O	36	G4	O		
16	S19	O	37	G5	O		
17	RPT	I	Reel pulse signal of tape up reel	38	G6	O	Segment signal for FL display
18	RPS	I	Reel pulse signal of supply reel	39	S1	O	
19	MP	O	Memory pulse signal ("L" for 50ms. with counter "0000")	40	S2	O	
20	DISP	I	Serial data signal (ACTIVE: "H")	41	S3	O	
21	GND	—	GND terminal	42	S4	O	



# BLOCK DIAGRAM

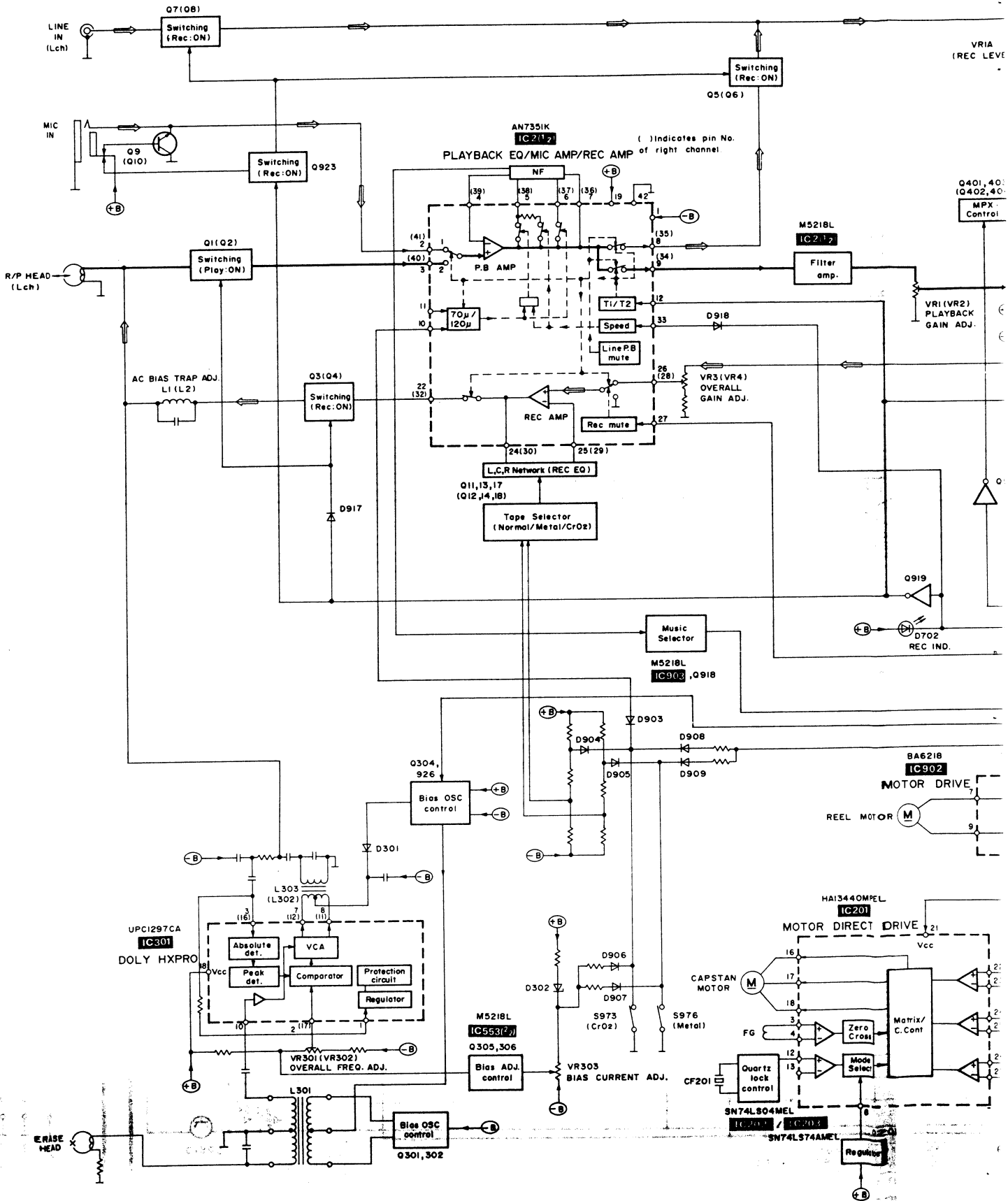

INTERNAL CONNECTION OF FL

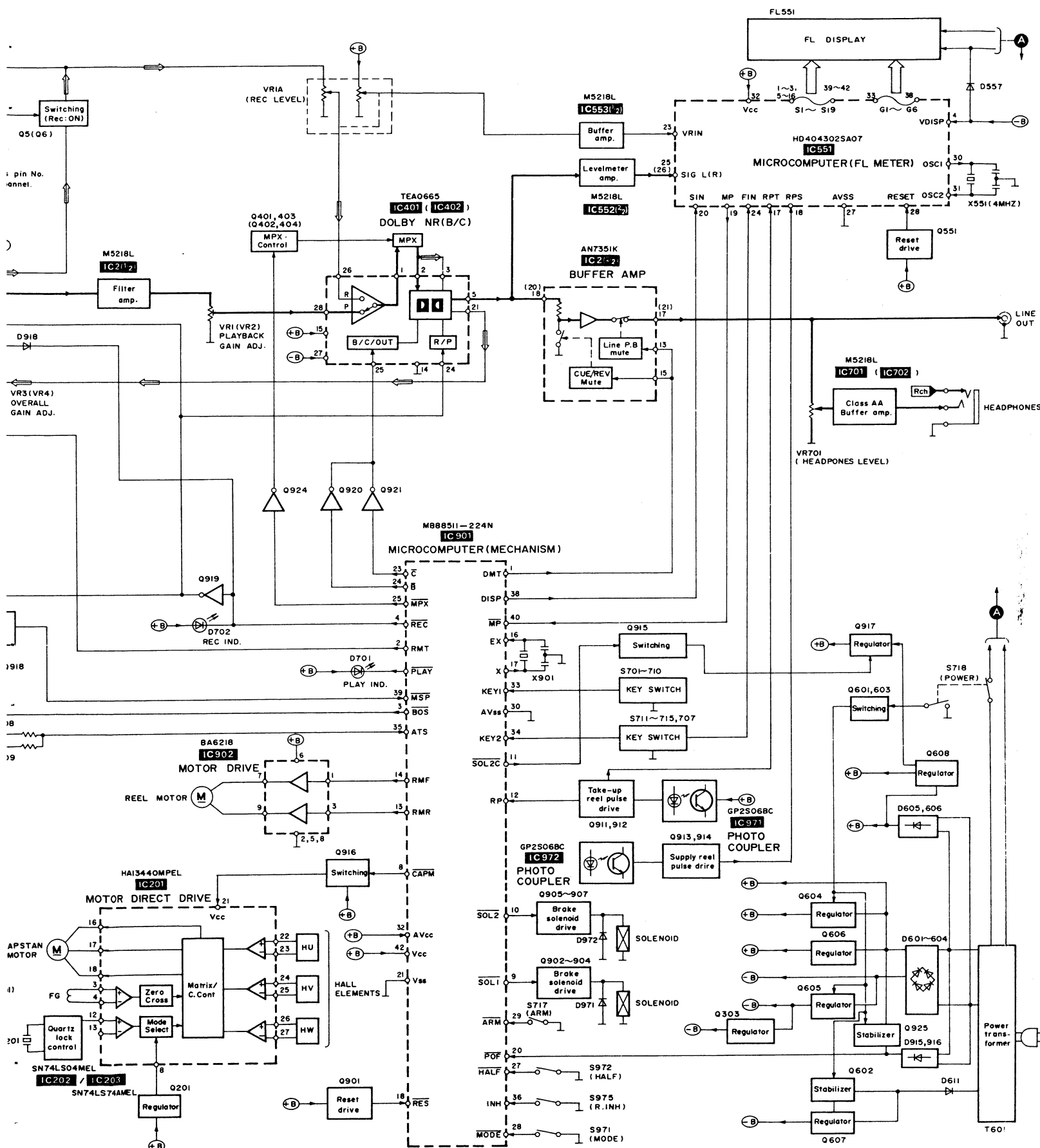

**Notes**  
 ● Playback signal  
 ● Recording signal

Grid connection diagram

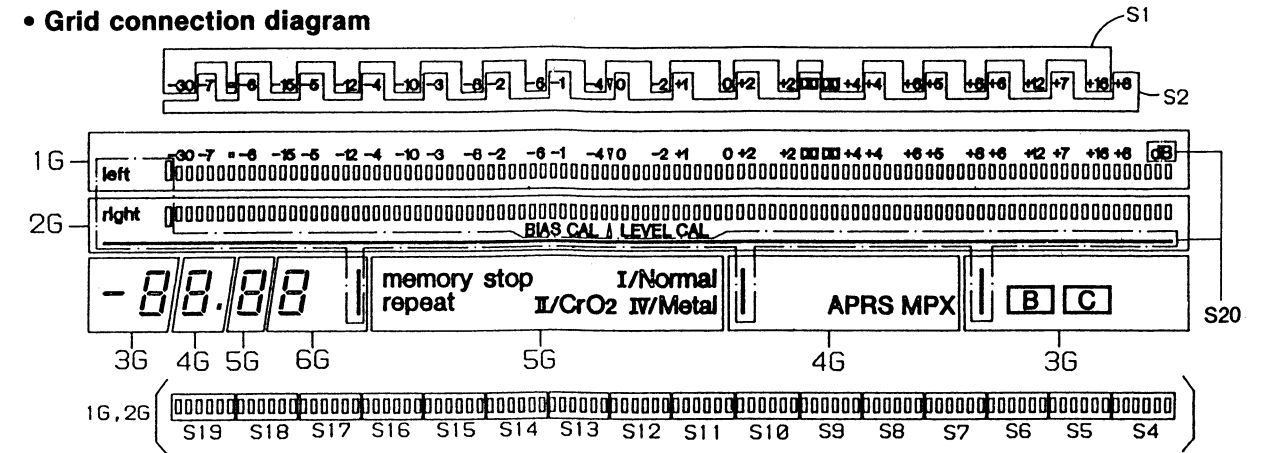

Anode connection table

	1G	2G	3G	4G	5G	6G
S1	S1	LEVEL CAL	-	APRS	-	-
S2	S2	BIAS CAL	-	-	-	-
S3	▼	▲	-	-	-	-
S4			-	-	-	-
S5			-	-	-	-
S6			-	-	memory	-
S7			-	-	repeat	-
S8			-	-	stop	-
S9			B	-	-	-
S10			C	-	I /Normal	-
S11			-	MPX	II /CrO <sub>2</sub>	-
S12			-	-	IV/Metal	-
S13			a	a	a	a
S14			b	b	b	b
S15			f	f	f	f
S16			g	g	g	g
S17			c	c	c	c
S18			e	e	e	e
S19			d	d	d	d
S20 (dB)	left   dB right				-	

Pin connection

PIN NO.	40	39	38	37	36	35	34	33	32	31	30	29	28	27	26	25	24	23	22	21	20	19	18	17	16	15	14	13	12	11	10	9	8	7	6	5	4	3	2	1	
CONNECTION	N	N	N	N	S	S	S	S	S	S	S	S	S	S	S	S	S	S	S	S	S	S	N	6	5	4	3	2	1	S	N	N	N	N	N	N	N	N	N	F	F
	P	P	P	P	P	P	P	P	P	P	P	P	P	P	P	P	P	P	P	P	P	P	C	G	G	G	G	G	G	G	20	P	P	P	P	P	P	P	P	1	1
PIN NO.	55	54	53	52	51	50	49	48	47	46	45	44	43	42	41																										
CONNECTION	F	F	N	N	N	N	N	N	N	N	N	N	N	N	N																										
	2	2	P	P	P	P	P	P	P	P	P	P	P	P	P																										

# SCHEMATIC DIAGRAM

(Parts list on pages 34, 35, 42~44.)

(This schematic diagram may be modified at any time with development of new technology.)

**Notes:**

- S701 : Stop switch (stop) in "off" position.
- S702 : F.F. switch (ff) in "off" position.
- S703 : Rew switch (rew) in "off" position.
- S704 : Playback switch (Play) in "off" position.
- S705 : Record switch (rec) in "off" position.
- S706 : Pause switch (pause) in "off" position.
- S707 : Dolby noise-reduction switch (Dolby NRC) in "off" position.
- S708 : Dolby noise-reduction switch (Dolby NR B) in "off" position.
- S709 : Multiplex filter switch (MPX filter) in "off" position.
- S710 : Timer switch (timer) in "off" position.
- S711 : Counter reset switch (counter reset) in "off" position.
- S712 : Counter mode switch (counter mode) in "off" position.
- S713 : Meter range switch (meter range) in "off" position.
- S714 : Memory mode switch (memory repeat) in "off" position.
- S715 : Memory mode switch (memory stop) in "off" position.
- S716 : APRS switch (APRS) in "off" position.
- S717 : Automatic-record-muting switch (auto rec mute) in "off" position.
- S718 : Power switch (standby  $\phi$  / on) in "on" position.
- S971 : Mode switch in "off" position.
- S972 : Cassette half detection switch in "off" position.
- S973 : ATS (CrO<sub>2</sub>) switch in "off" position.
- S975 : Rec Inhibit switch in "off" position.
- S976 : ATS (Metal) switch in "off" position.

- Resistance are in ohms ( $\Omega$ ), 1/4 watt unless specified otherwise.
- 1K=1,000 ( $\Omega$ ), 1M=1,000k ( $\Omega$ )
- Capacity are in micro-farads ( $\mu$ F) unless specified otherwise.
- All voltage values shown in circuitry are under no signal condition and playback mode with volume control at minimum position otherwise specified.

- ( ) .....Voltage values at record mode.
- For measurement use EVM.
- Important safety notice
- Components identified by  $\Delta$  mark have special characteristics important for safety. When replacing any of these components, use only manufacturer's specified parts.
- (  $\text{---} \langle +B \rangle \text{---}$  ) indicates +B (bias).
- (  $\text{---} \langle -B \rangle \text{---}$  ) indicates -B (bias).
- (  $\text{---} \langle \text{PLAYBACK SIGNAL} \rangle \text{---}$  ) indicates the flow of the playback signal.
- (  $\text{---} \langle \text{RECORD SIGNAL} \rangle \text{---}$  ) indicates the flow of the record signal.

- \* Caution!**  
 IC and LSI are sensitive to static electricity.  
 Secondary trouble can be prevented by taking care during repair.  
 \* Cover the parts boxes made of plastics with aluminum foil.  
 \* Ground the soldering iron.  
 \* Put a conductive mat on the work table.  
 \* Do not touch the legs of IC or LSI with the fingers directly.

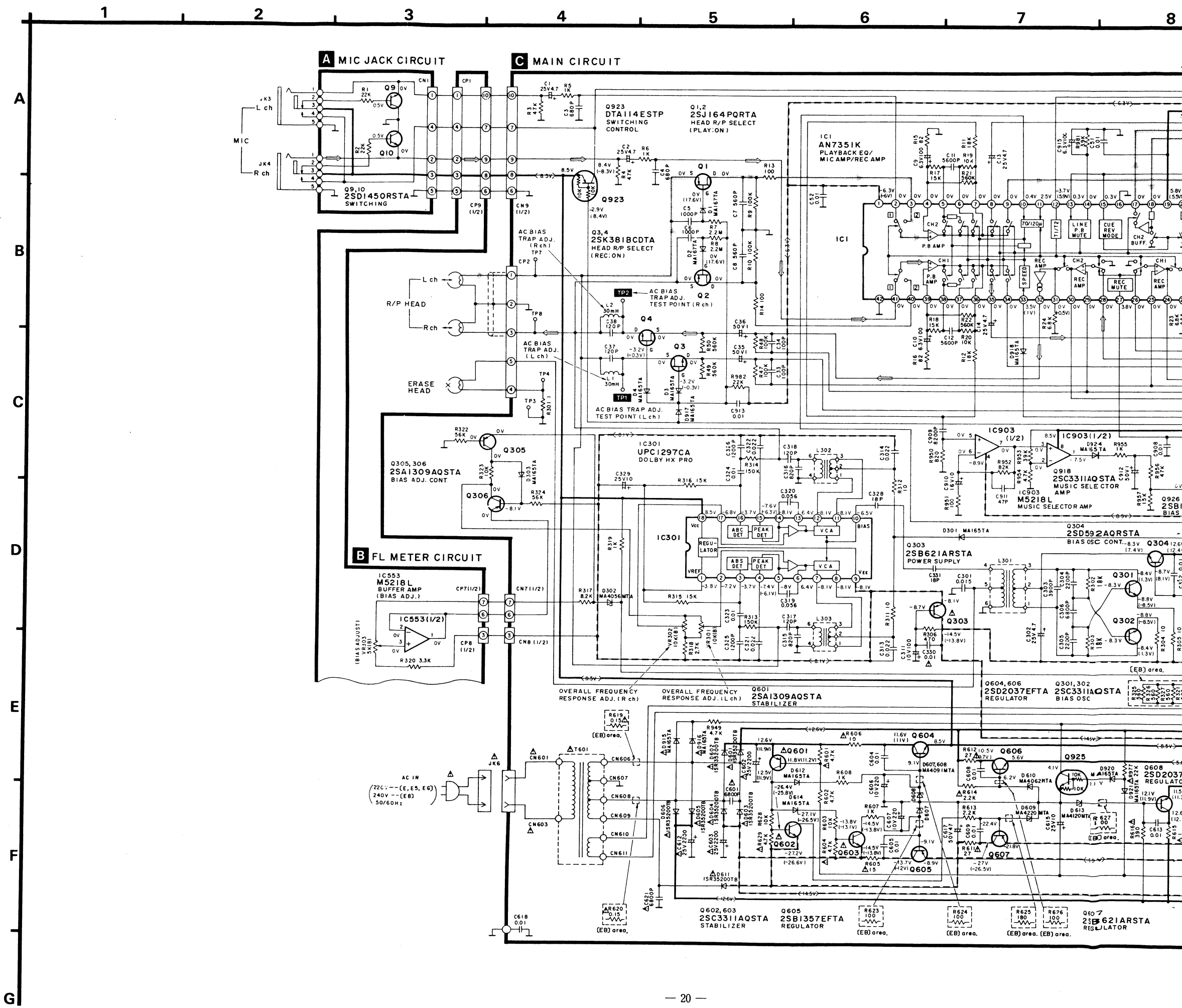





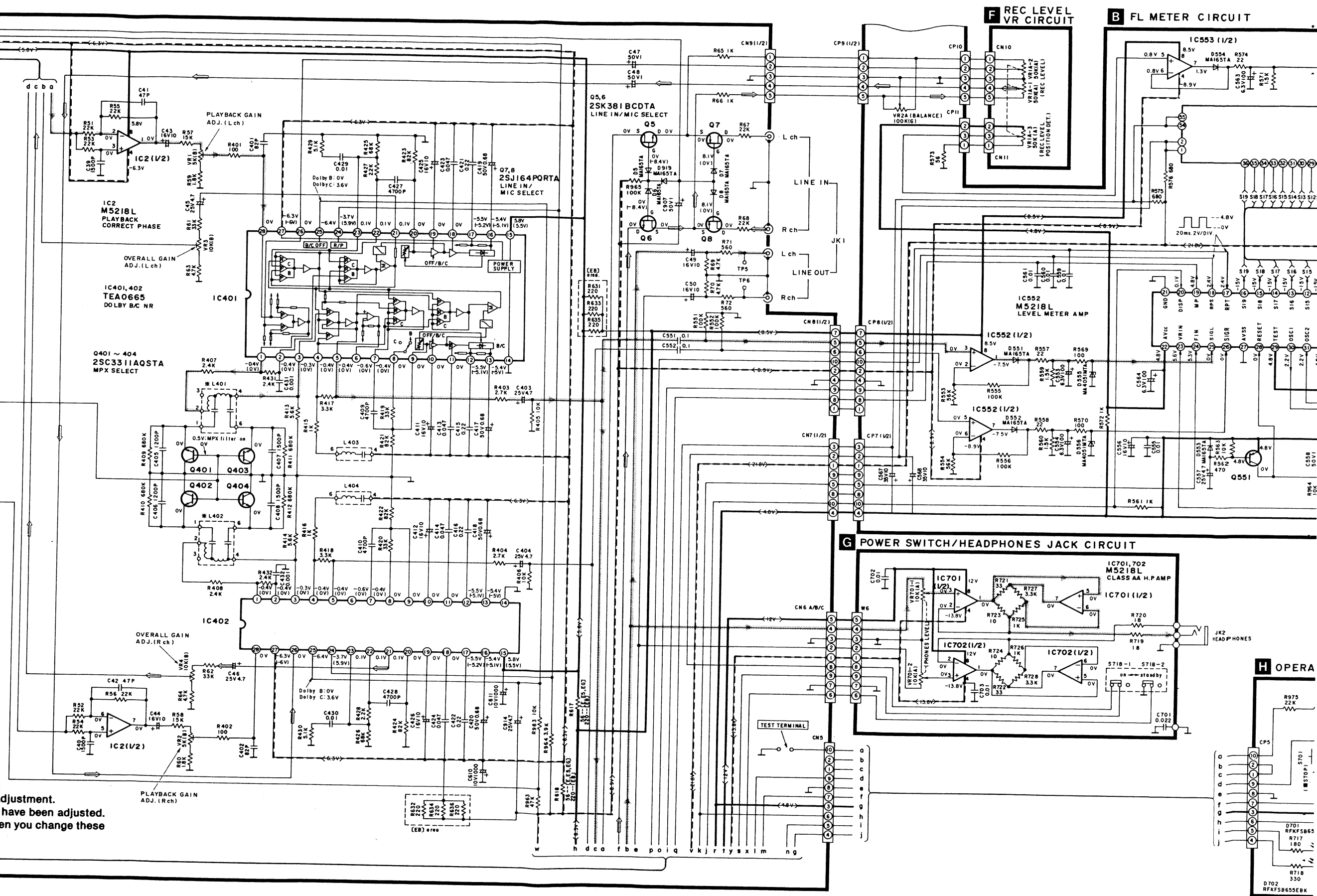

※ These are the parts for MPX effect adjustment.  
 When these parts are supplied, they have been adjusted.  
 Thus it does not need to readjust when you change these parts.

LEVEL CIRCUIT

B FL METER CIRCUIT

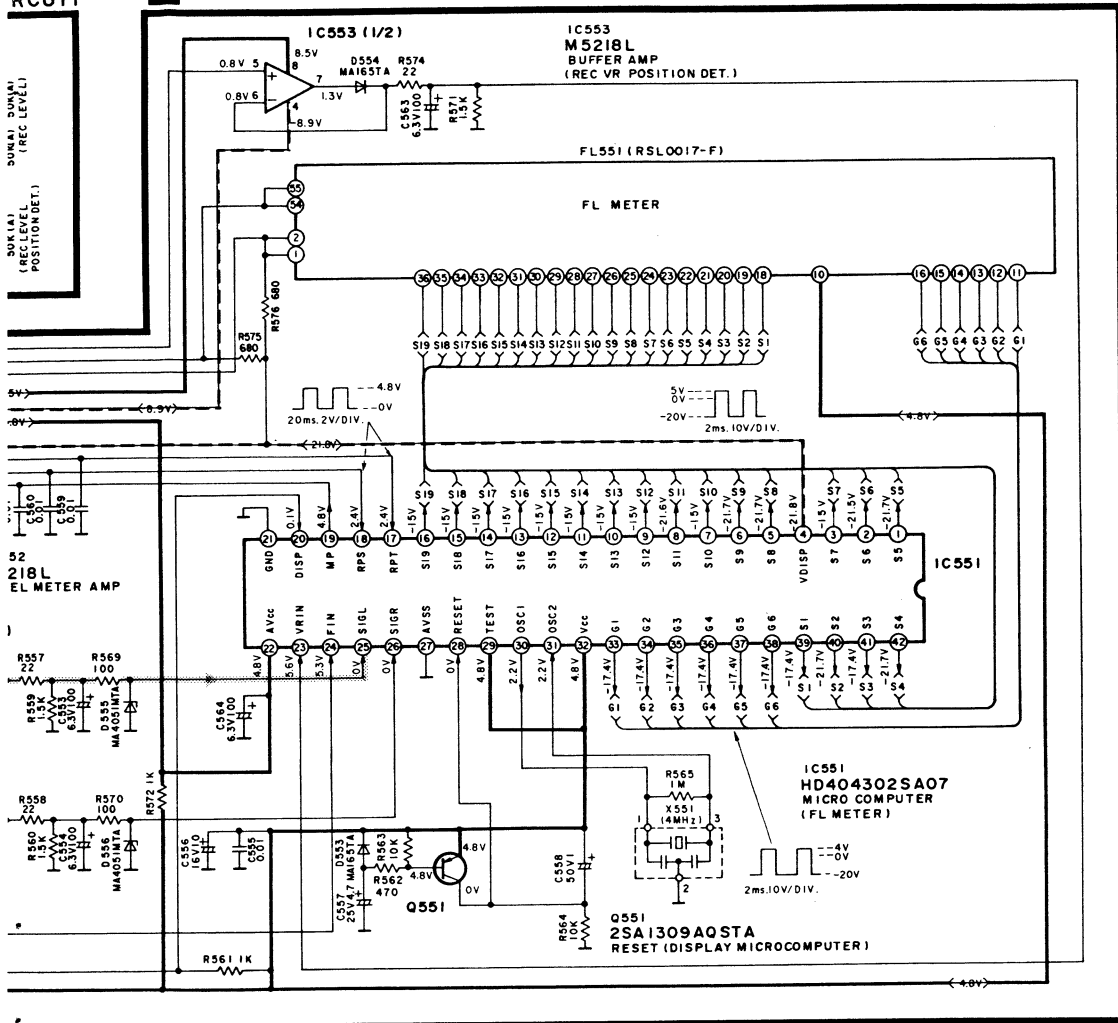

ES JACK CIRCUIT

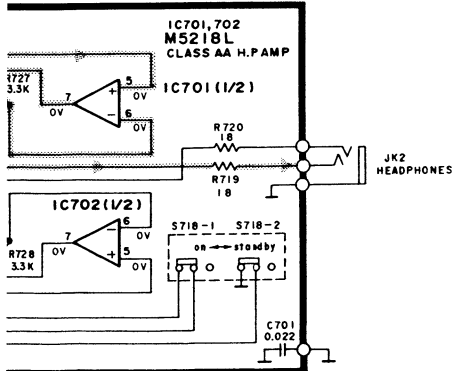

H OPERATION SWITCH CIRCUIT

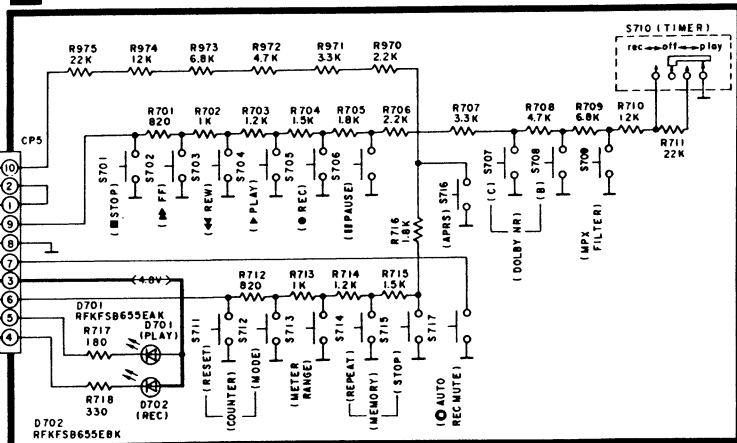

I CAPSTAN MOTOR(D.D) CIRCUIT

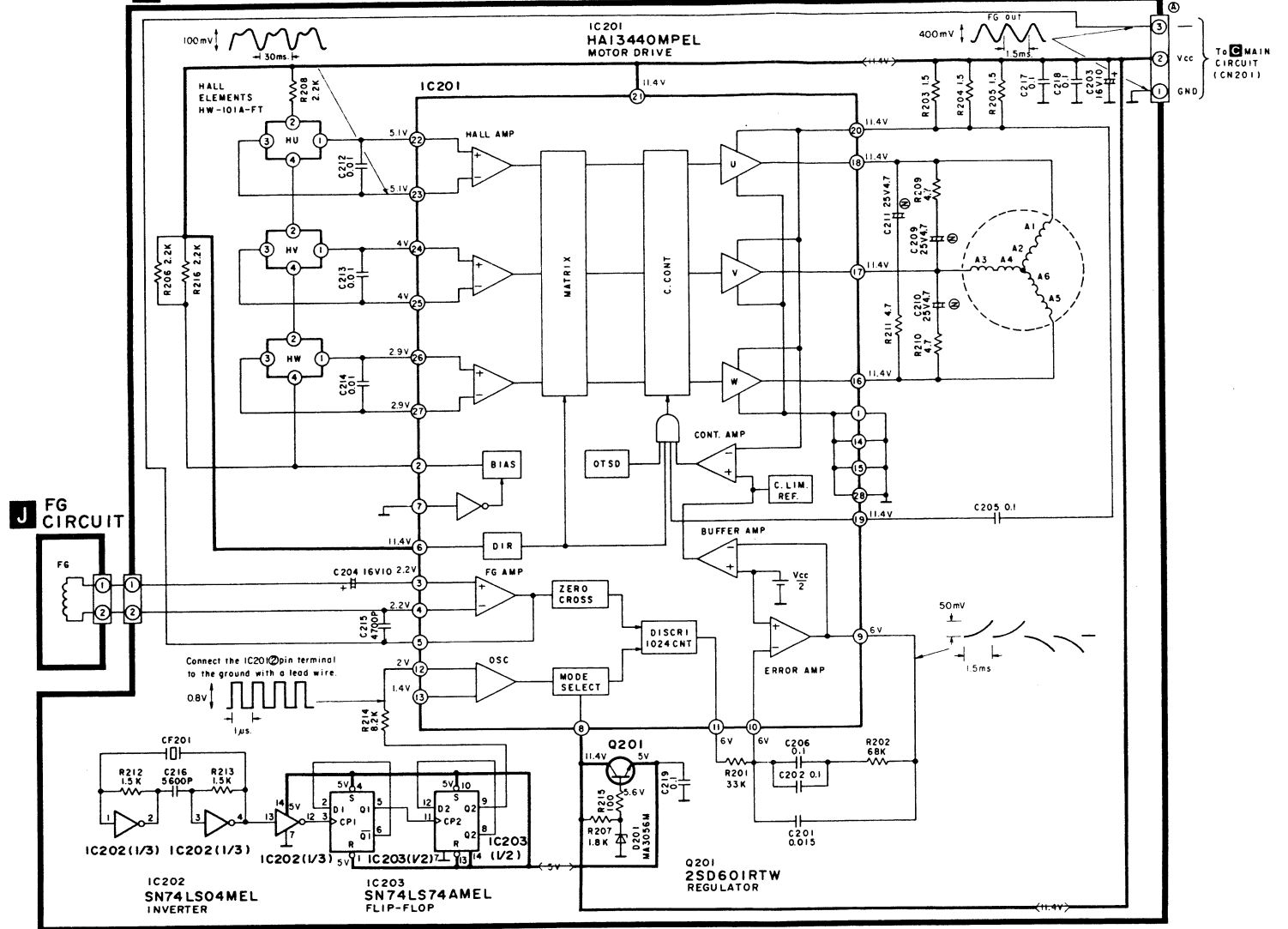

J FG CIRCUIT

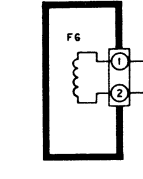





TROUBLESHOOTING OF DIRECT DRIVE MOTOR

Problem	Possible Cause	Check Points
1. The motor does not rotate.	1. No power supply (+12V) 2. The Hall element has failed (Current does not flow). 3. The ceramic (or crystal) does not oscillate.	• Check the voltage applied to the connector. • Check the DC potential on IC pins ②~⑦. * Check the waveform of IC pin ⑬.
2. The motor does not rotate properly. (When pressed, it stops at certain angles. Sometimes it does not rotate even if power is ON.)	1. The coil is broken or not properly soldered. 2. Output of the Hall element is not proper.	* Check the conductance of the coil. If normal, the resistances between IC pins ⑩~⑬, ⑭~⑯ will reach 20 ohms. • Check the waveform of IC pins ②~⑦.
3. The motor is out of control.	1. The FG coil is broken.	• Check the waveform of IC pin ⑤. • Check if the FG coil is broken.
4. Abnormal wow	1. Same as those described for problem 2.	

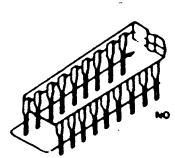
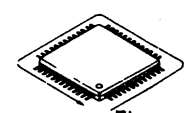
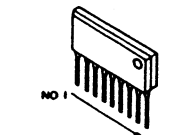
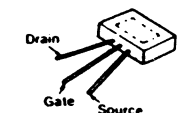
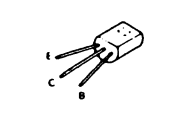
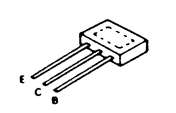
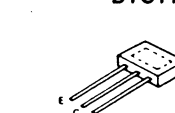
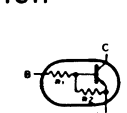
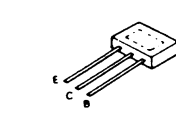
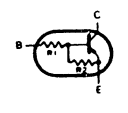
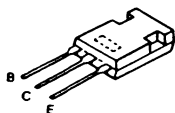
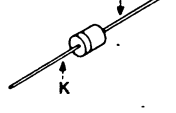
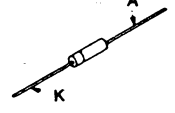
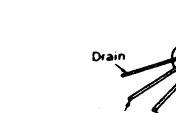
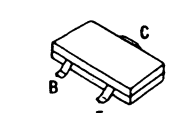
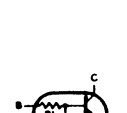
**Note:** Check the points marked with an asterisk (\*) by removing the DD motor control P.C.B. and then connecting IC pin ② to GND with a lead wire. (After the DD motor control P.C.B. is removed, current will start flowing through the coil, heating the IC.)

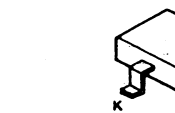
**TERMINAL GUIDE OF IC'S,  
TRANSISTORS AND DIODES**

 <table border="1"> <tr><td>UPC1297CA</td><td>18 Pin</td></tr> <tr><td>TEA0665</td><td>28 Pin</td></tr> <tr><td>AN7351K</td><td>42 Pin</td></tr> <tr><td>HD404302SA07</td><td>42 Pin</td></tr> <tr><td>MB88511-224N</td><td>42 Pin</td></tr> </table>	UPC1297CA	18 Pin	TEA0665	28 Pin	AN7351K	42 Pin	HD404302SA07	42 Pin	MB88511-224N	42 Pin	 <table border="1"> <tr><td>HA13440MPEL</td><td>30 Pin</td></tr> </table>	HA13440MPEL	30 Pin
UPC1297CA	18 Pin												
TEA0665	28 Pin												
AN7351K	42 Pin												
HD404302SA07	42 Pin												
MB88511-224N	42 Pin												
HA13440MPEL	30 Pin												
 <table border="1"> <tr><td>M5218L</td><td>8 Pin</td></tr> <tr><td>BA6218</td><td>9 Pin</td></tr> </table>	M5218L	8 Pin	BA6218	9 Pin	<p>2SJ164PQRTA</p>  <p>Drain Gate Source</p>								
M5218L	8 Pin												
BA6218	9 Pin												
 <p>2SB621ARSTA 2SD592A</p>	 <p>2SA1309AQSTA 2SC3311AQSTA 2SD1450RSTTA 2SB1030RSTTA</p>												
<p>DTC114ESTP DTC114YSTP</p>  	<p>DTA114ESTP</p>  												
 <p>2SB1357DEFTA 2SD2037EFTA</p>	 <p>MA167TA MA165TA 1SR35200TB 1SS133</p>												
 <p>MA4200M MA4047MTA MA4091MTA MA4062HTA MA4120M MA4330MTA MA4056H MA4051MTA MA4056MTA</p>	<p>2SK381BCDTA</p>  <p>Drain Gate Source</p>												
<p>2SD601RTW</p>  	<table border="1"> <tr><td>SN74LS04MEL</td><td>14 Pin</td></tr> <tr><td>SN74LS74AMEL</td><td>14 Pin</td></tr> </table> 	SN74LS04MEL	14 Pin	SN74LS74AMEL	14 Pin								
SN74LS04MEL	14 Pin												
SN74LS74AMEL	14 Pin												
<p>MA3056MTW</p>  													

**PRINTED CIRCUIT BOARDS**

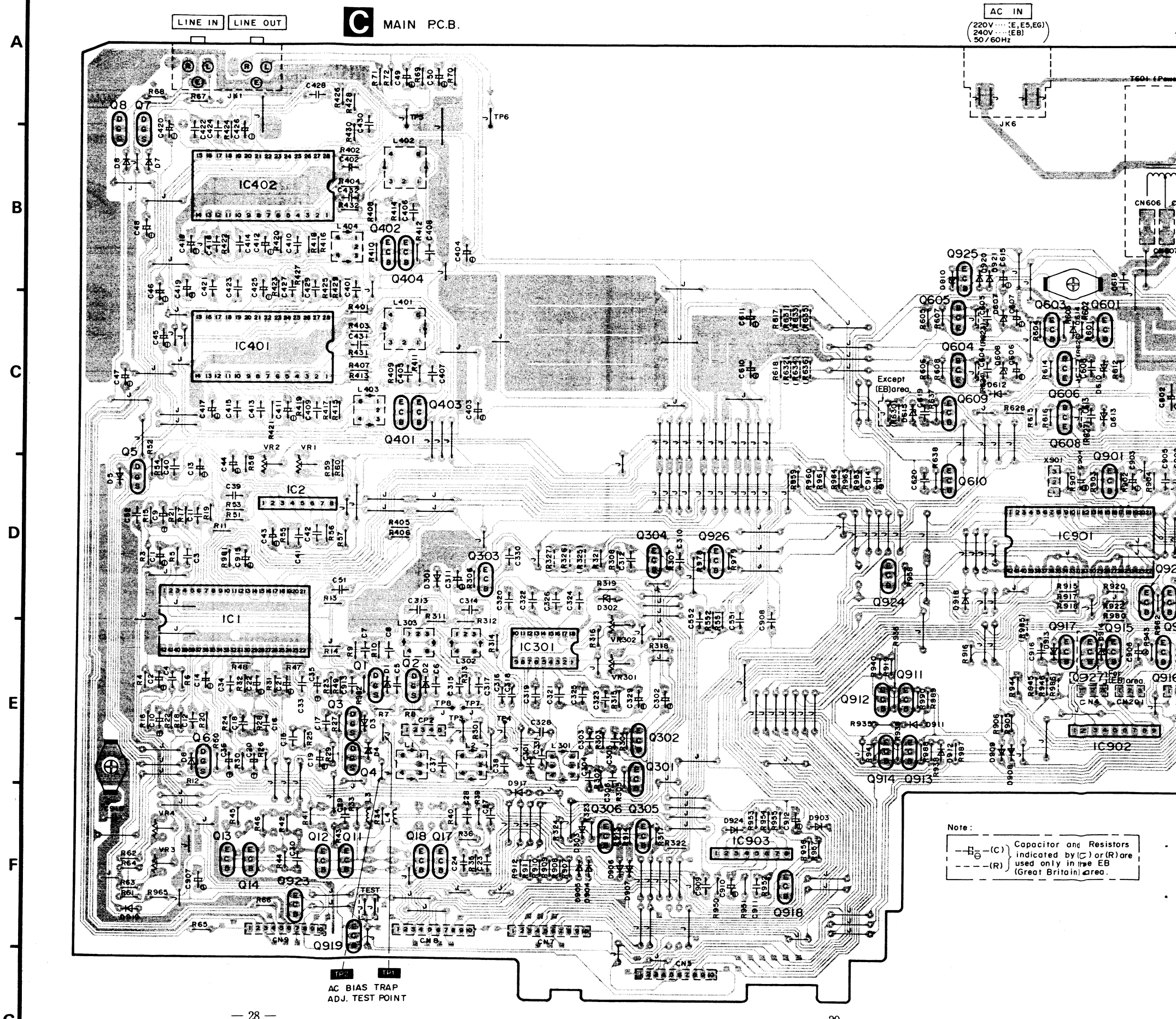





**I** CAPSTAN MOTOR (D.D) P.C.B.

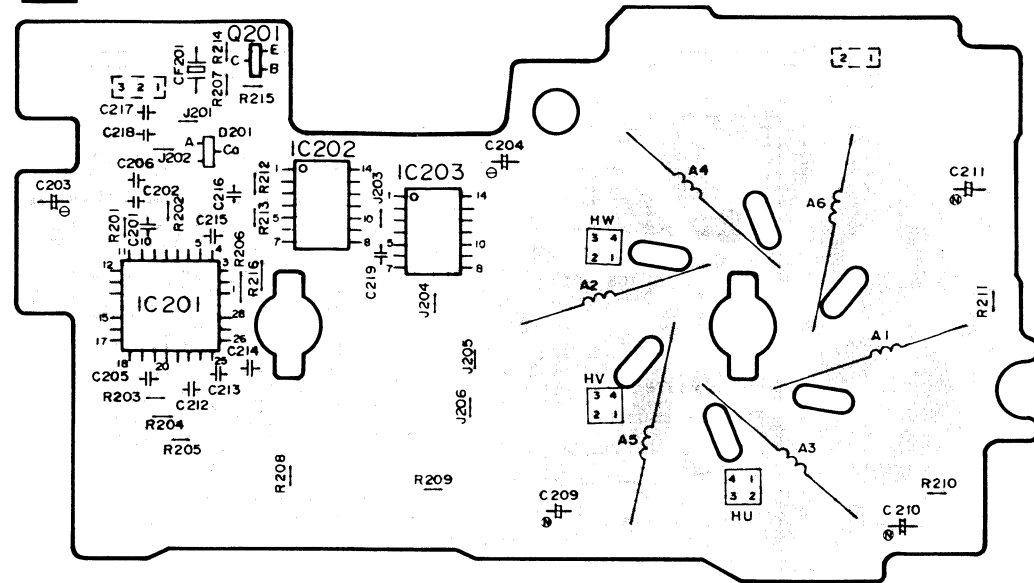

**J** FG P.C.B.

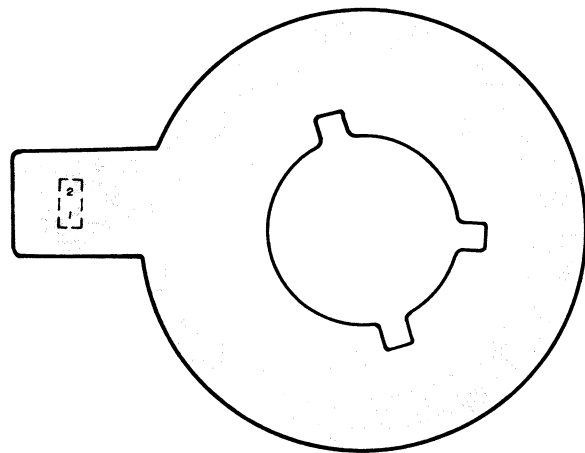

**D** MECHANISM P.C.B.

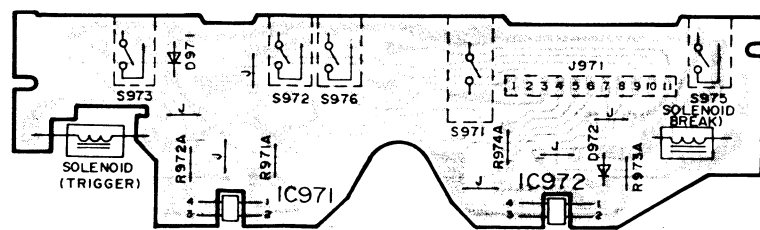

**WIRING CONNECTION DIAGRAM**

**E** REEL MOTOR P.C.B.

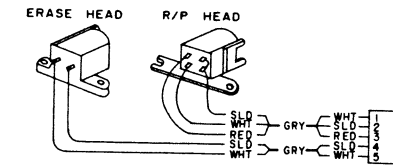
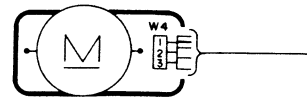

**F** REC LEVEL VR P.C.B.

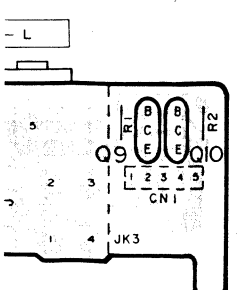
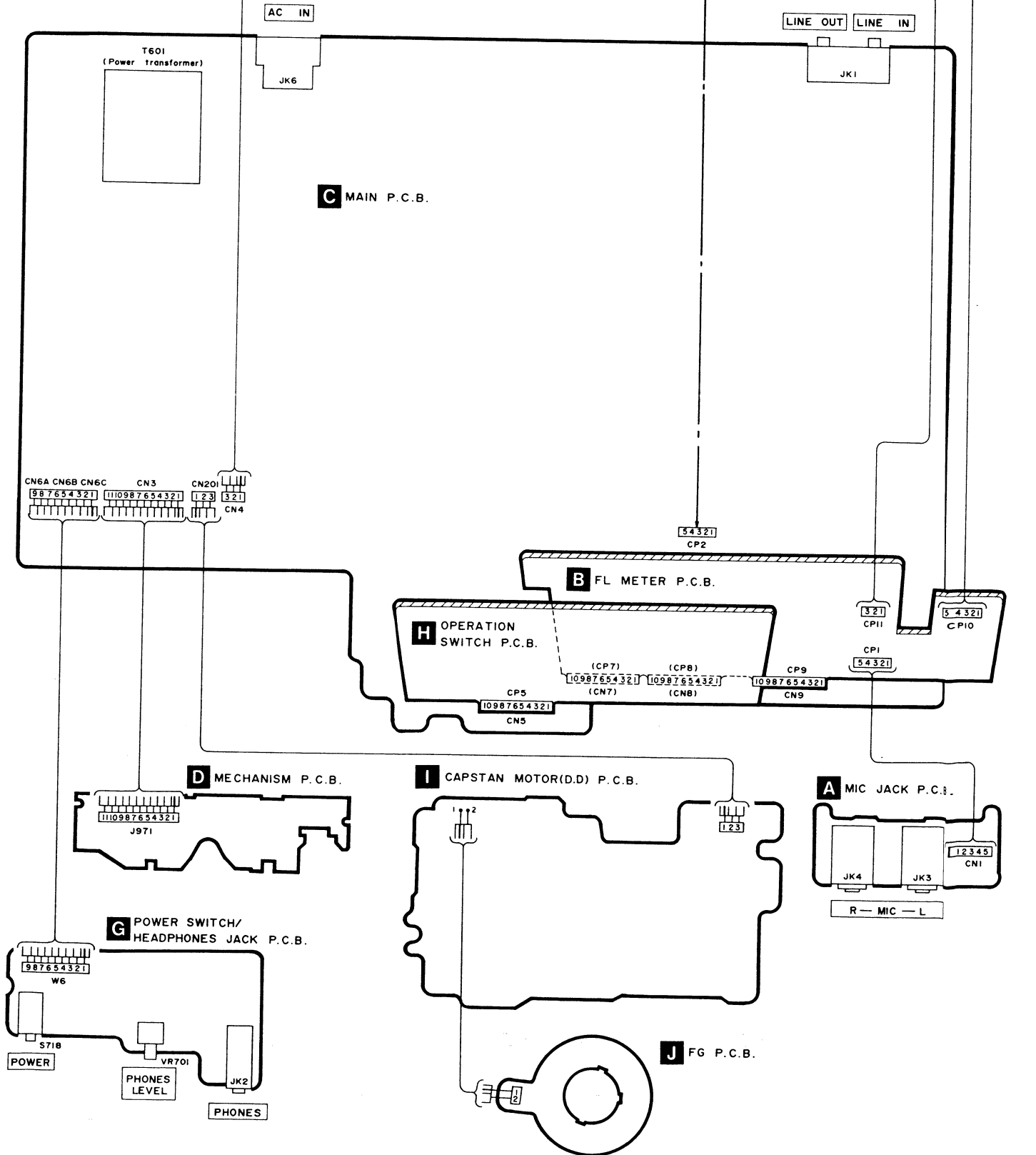
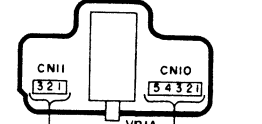

# REPLACEMENT PARTS LIST

Notes : • Important safety notice:  
 Components identified by  $\Delta$  mark have special characteristics important for safety. When replacing any of these components use only manufacturer's specified parts.  
 • The parenthesized indications in the Remarks column specify the areas. (Refer to the cover page for area.)  
 Parts without these indications can be used for all areas.

Ref. No.	Part No.	Part Name & Description	Remarks
		INTEGRATED CIRCUIT(S)	
IC1	AN7351K	IC, PLAYBACK EQ./MIC AMP	
IC2	ME218L	IC, PLAYBACK CORRECT PHASE	
IC201	HA1344AMP	IC, MOTOR DRIVE	
IC202	SN74LS04AMEL	IC, INVERTER	
IC203	SN74LS74AMEL	IC, FLIP-FLOP	
IC301	UPC1297CA	IC, DOLBY HK PRO	
IC401, 402	TEA0665	IC, DOLBY B/C NR	
IC551	HD404302SA07	IC, MICROCOMPUTER; FL. METER	
IC552	ME218L	IC, LEVEL METER AMP	
IC553	ME218L	IC, BUFFER AMP	
IC701, 702	ME218L	IC, Class AA : H. P. AMP	
IC901	MB88511-224N	IC, MICROCOMPUTER; MECHANICAL	
IC902	BA6218	IC, REEL MOTOR CONTROL	
IC903	ME218L	IC, MUSIC SELECTOR AMP	
IC971, 972	QP2S06BC	IC, PHOTO COUPLER	
		TRANSISTOR(S)	
Q1, 2	ZSJ164PQRTA	TRANSISTOR	
Q3-6	ZSK381BCDTA	TRANSISTOR	
Q7, 8	ZSJ164PQRTA	TRANSISTOR	
Q9, 10	ZSD145ORSTA	TRANSISTOR	
Q11-14	ZSC3311AQSTA	TRANSISTOR	
Q17, 18	ZSA1309AQSTA	TRANSISTOR	
Q201	ZSD601RTW	TRANSISTOR	
Q301, 302	ZSC3311AQSTA	TRANSISTOR	
Q303	ZSB621ARSTA	TRANSISTOR	$\Delta$
Q304	ZSD592A	TRANSISTOR	
Q305, 306	ZSA1309AQSTA	TRANSISTOR	
Q401-404	ZSC3311AQSTA	TRANSISTOR	
Q551	ZSA1309AQSTA	TRANSISTOR	
Q601	ZSA1309AQSTA	TRANSISTOR	$\Delta$
Q602, 603	ZSC3311AQSTA	TRANSISTOR	$\Delta$
Q604	ZSD2037EFTA	TRANSISTOR	
Q605	ZSB1357EFTA	TRANSISTOR	
Q606	ZSD2037EFTA	TRANSISTOR	
Q607	ZSB621ARSTA	TRANSISTOR	
Q608	ZSD2037EFTA	TRANSISTOR	
Q609	ZSC3311AQSTA	TRANSISTOR	$\Delta$
Q901	ZSA1309AQSTA	TRANSISTOR	$\Delta$
Q901	ZSC3311AQSTA	TRANSISTOR	
Q902	DTA114ESTP	TRANSISTOR	
Q903	DTA114ESTP	TRANSISTOR	
Q904	ZSB1030RSTTA	TRANSISTOR	$\Delta$
Q905	DTA114ESTP	TRANSISTOR	
Q906	DTC114ESTP	TRANSISTOR	
Q907	ZSB1030RSTTA	TRANSISTOR	$\Delta$
Q908	DTC114YSTP	TRANSISTOR	
Q909	ZSC3311AQSTA	TRANSISTOR	
Q910	ZSB1030RSTTA	TRANSISTOR	$\Delta$
Q911	ZSC3311AQSTA	TRANSISTOR	
Q912	DTC114ESTP	TRANSISTOR	
Q913	ZSC3311AQSTA	TRANSISTOR	
Q914	DTC114ESTP	TRANSISTOR	
Q915	DTC114YSTP	TRANSISTOR	
Q916	ZSB1030RSTTA	TRANSISTOR	
Q917	ZSD692A	TRANSISTOR	
Q918	ZSC3311AQSTA	TRANSISTOR	
Q919-921	DTA114ESTP	TRANSISTOR	
Q923, 924	DTA114ESTP	TRANSISTOR	
Q925	DTC114ESTP	TRANSISTOR	
Q926	ZSB1030RSTTA	TRANSISTOR	
Q927	ZSC3311AQSTA	TRANSISTOR	(EB)
		DIODE(S)	
D1, 2	MA1677A	DIODE	
D3-8	MA1657A	DIODE	
D201	MA3056MTW	DIODE	
D301	MA1657A	DIODE	
D302	MA4056MTA	DIODE	
D303	MA1657A	DIODE	
D551-554	MA1657A	DIODE	
D555, 556	MA4051MTA	DIODE	
D601-606	1SR35200TB	DIODE	$\Delta$
D607, 608	MA4091MTA	DIODE	
D609	MA4220M	DIODE	
D610	MA4062HTA	DIODE	
D611	1SR35200TB	DIODE	$\Delta$
D612	MA1657A	DIODE	
D613	MA4120M	DIODE	
D614	MA1657A	DIODE	
D615	MA4330MTA	DIODE	
D701	RFNFSB655EAK	L. E. D ASS'Y	
D702	RFNFSB655EBK	L. E. D ASS'Y	
D901, 902	1SR35200TB	DIODE	
D903	MA1657A	DIODE	$\Delta$
D904-909	MA1657A	DIODE	
D910	MA4051MTA	DIODE	
D911, 912	MA1657A	DIODE	
D913	MA4056H	DIODE	

Ref. No.	Part No.	Part Name & Description	Remarks
D914	MA4091MTA	DIODE	
D915, 916	MA1657A	DIODE	$\Delta$
D917-921	MA1657A	DIODE	
D924	MA1657A	DIODE	
D971, 972	1SS133	DIODE	
		VARIABLE RESISTOR(S)	
VR1, 2	EYNDXA00B53	V. R. PLAYBACK GAIN ADJ.	
VR1A	EWGU2A029A54	V. R. REC. LEVEL CONTROL	
VR2A	EVJ02SF06G15	V. R. BALANCE CONTROL	
VR3, 4	EYNDXA00B14	V. R. OVERALL GAIN ADJ.	
VR301, 302	EYNDXA00B14	V. R. OVERALL FREQ. ADJ.	
VR303	EVJ02VF04B53	V. R. BIAS CURRENT ADJ.	
VR701	EVU57A043A14	V. R. HEADPHONES CONTROL	
		COIL(S)	
L1, 2	RL20003	COIL	
L3, 4	SLQK272-1YT	COIL	
L301	SL09B4-K	COIL	
L302, 303	SL09B1-K	COIL	
L401, 402	QLM3210K	COIL	
L403, 404	SLM1B8-K	COIL	
		TRANSFORMER(S)	
T601	RTP1K48007-V	POWER TRANSFORMER	(EB) $\Delta$
T601	RTP1K4E008-V	POWER TRANSFORMER	(E, E5, EG) $\Delta$
		OSCILLATOR(S)	
X551	EFOCC4004T4	CERAMIC FILTER	
X901	EFOCC6004T4	CERAMIC FILTER	
		DISPLAY TUBE	
FL551	RSL0017-F	DISPLAY TUBE (FL. METER)	
		SWITCH(ES)	
S701	EVQQTG05R	SW. STOP	
S702	EVQQTG05R	SW. F. F.	
S703	EVQQTG05R	SW. REV.	
S704	EVQQTG05R	SW. PLAYBACK	
S705	EVQQTG05R	SW. RECORD	
S706	EVQQTG05R	SW. PAUSE	
S707	EVQQTG05R	SW. DOLBY NR C	
S708	EVQQTG05R	SW. DOLBY NR B	
S709	EVQQTG05R	SW. MPX FILTER	
S710	SSS166	SW. TIMER	
S711	EVQQTG05R	SW. COUNTER RESET	
S712	EVQQTG05R	SW. COUNTER MODE	
S713	EVQQTG05R	SW. METER RANGE	
S714	EVQQTG05R	SW. MEMORY REPEAT	
S715	EVQQTG05R	SW. MEMORY STOP	
S716	EVQQTG05R	SW. APS	
S717	EVQQTG05R	SW. AUTO REC. MUTE	
S718	SSH1230	SW. POWER	
S971	RSHIA892	SW. MODE	
S972	RSHIA90Z	SW. HALF	
S973	RSHIA90Z	SW. ATS	
S975	RSHIA90Z	SW. REC. INHIBIT	
S976	RSHIA90Z	SW. ATS	
		CONNECTOR(S) AND SOCKET(S)	
CN1	SJT30545JQ	CONNECTOR (5P)	
CN3	SJSD1105	CONNECTOR (11P)	
CN4	RJSIA1703	CONNECTOR/CONNECTOR (3P)	
CN5	RJU003K010M	SOCKET (10P)	
CN6A-6C	RJSIA1703	CONNECTOR (3P)	
CN7-9	RJU003K010M	SOCKET (10P)	
CN10	SJT30545JQ	CONNECTOR (5P)	
CN11	SJT30345JQ	CONNECTOR (3P)	
CN201	RJSIA1703	CONNECTOR (3P)	
CN201A	RJS2T42A	CONNECTOR (2P)	
CN601	RJSIA1101	SOCKET (1P)	$\Delta$
CN603	RJSIA1101	SOCKET (1P)	$\Delta$
CN606-611	RJSIA1101	SOCKET (1P)	
CP1	SJS50578JQ	SOCKET (5P)	
CP2	SJTD513	CONNECTOR (5P)	
CP5	RJT003K010	CONNECTOR (10P)	
CP7-9	RJT003K010	CONNECTOR (10P)	
CP10	SJS50578JQ	SOCKET (5P)	
CP11	SJS50378JQ	SOCKET (3P)	
		GND PART(S)	
E1-3	SNE1004-1	GND. PLATE	
E701	SUSD165	GND. SPRING	
		JACK(S)	
JK1	SJF3069N	TERMINAL BOARD	
JK2	SJJ146B	JACK, HEADPHONES	
JK3, 4	RJ365SD01	JACK, MIC	
JK6	SJS9236	AC INLET	$\Delta$
		CERAMIC FILTER(S)	
CF201	RSXA3M74S01	CERAMIC FILTER	
		JAMPER(S)	
J201-206	ERJ6GEYDROOV	CHIP JAMPER	

Notes : • Important safety notice:  
 Components identified by  $\Delta$  mark have special characteristics important for safety. When replacing any of these components use only manufacturer's specified parts.  
 • The parenthesized indications in the Remarks column specify the areas. (Refer to the cover page for area.)  
 Parts without these indications can be used for all areas.

Ref. No.	Part No.	Part Name & Description	Remarks	Ref. No.	Part No.	Part Name & Description	Remarks
		CABINET AND CHASSIS		40	RSC0076	SHIELD PLATE	
				41	RL0030	PANEL LIGHT	
				42	RK0009	BOTTOM BOARD	
1	RK0036-K	CABINET		43	XTB3-10G	SCREW	
2	RYF0027	CASSETTE LID				PACKING MATERIAL	
3	RYQ0027	ORNAMENT					
4	SNE2129-1	SCREW		P1	RP00255	CARTON BOX	
5	XTB3-8JFZ1	SCREW		P2	RP0178	PAD, FRONT/BACK	
6	RM0021	FL HOLDER		P3	SPS5185	PAD, ACCESSORIES	
7	RSC0048	SHIELD PLATE		P4	SPP756	PROTECTION COVER	
8	RG0024-A	REAR PANEL	(E)			ACCESSORIES	
8	RG0024-C	REAR PANEL	(E5)	A1	RQF0239	INSTRUCTION MANUAL	(EG)
8	RG0024-E	REAR PANEL	(EB)	A1	RQF0240	INSTRUCTION MANUAL	(E, E5)
8	RG0024-L	REAR PANEL	(EG)	A1	RQF0241	INSTRUCTION MANUAL	(EB)
9	RGU0030	BUTTON, POWER		A2	SFDAC05E03	POWER CORD	(E, E5, EG) $\Delta$
10	RGV0022	KNOB, TIMER		A2	SJA193-1	POWER CORD	(EB) $\Delta$
11	RGW0032	KNOB, BALANCE LEVEL		A3	SJP2249-3	STEREO CONNECTION CABLE	
12	RGW0033	KNOB, REC LEVEL					
13	RKA0009-1	FOOT					
14	RFKNSB655EAK	FRONT GRILLE ASS'Y (1)					
14-1	RK0038	TRANSPARENT PLATE					
15	RFKNSB655EBK	FRONT GRILLE ASS'Y (2)					
16	RM0040	BRACKET					
17	RM0056	SHIELD PLATE					
18	RM0026-1	CHASSIS					
19	RM0022	ORNAMENT					
20	RFKNSB655E-K	FRONT PANEL ASS'Y				MECHANISM UNIT	
21	RG0117	ORNAMENT, BUTTON (A)		MECH1	RAA0802	MECHANISM ASS'Y	
22	RG0118	ORNAMENT, BUTTON (B)					
23	RGU0130	BUTTON, EJECT				PRINTED CIRCUIT BOARDS	
24	RGU0131	BUTTON, COUNTER					
25	RGU0132	BUTTON, NOISE REDUCTION					
26	RGU0133	BUTTON, OPERATION		PWB1	REP0306A	MAIN P. C. B. ASS'Y	(E, E5, EG)
27	RKF0020A-3	CASSETTE HOLDER		PWB1	REP0306B	MAIN P. C. B. ASS'Y	(EB)
27-1	QBP2006A	SPRING, TAPE PRESSURE		PWB2	REP0307A	SUB P. C. B. ASS'Y	
28	RMED032	SPRING					
29	RMED034	SPRING					
30	RML0086	EJECT LEVER					
31	RM0153	DAMPER GEAR ASS'Y					
32	XTB3-10JFZ	SCREW					
33	SJD444-1	WASHER					
34	SHE187-2	HOLDER					
35	SNE4021-1	NUT					
36	XTB3-16G	SCREW					
37	XTB3-20J	SCREW					
38	XTB3-8JFZ	SCREW					
39	XTB26-4FFZ	SCREW					

# EXPLODED VIEWS

• Cabinet parts

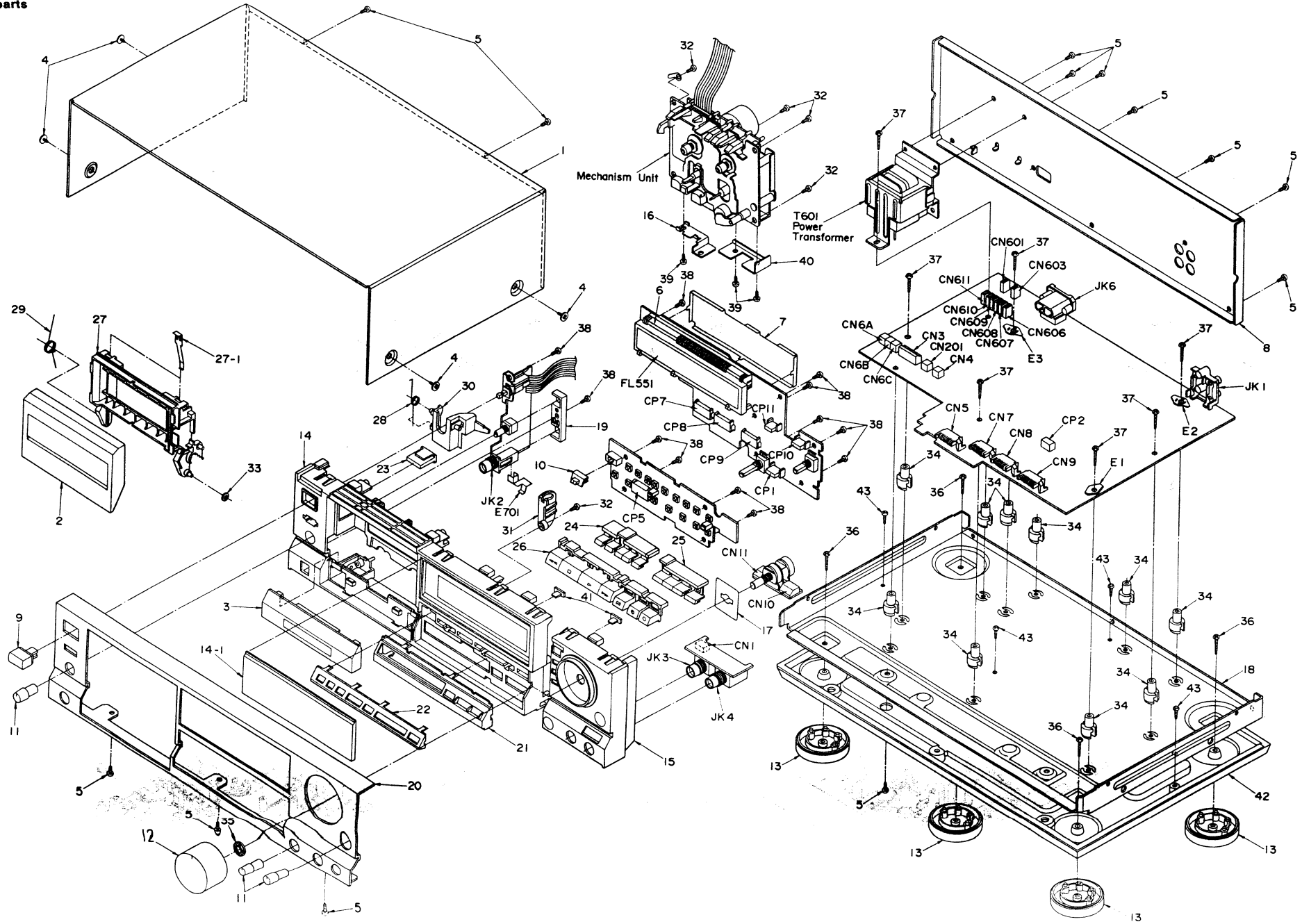



• Mechanical parts  
(Top view)

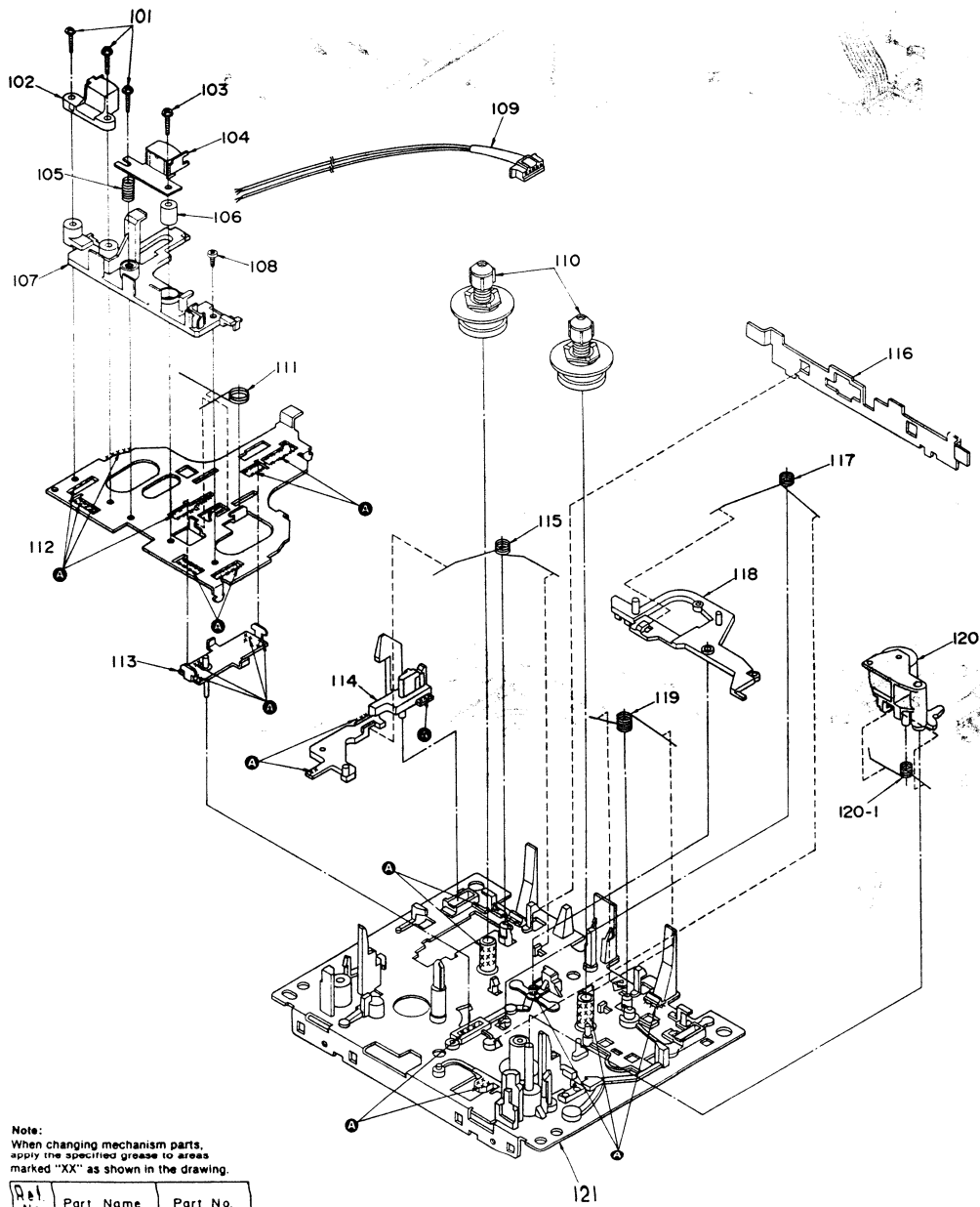

(Bottom view)

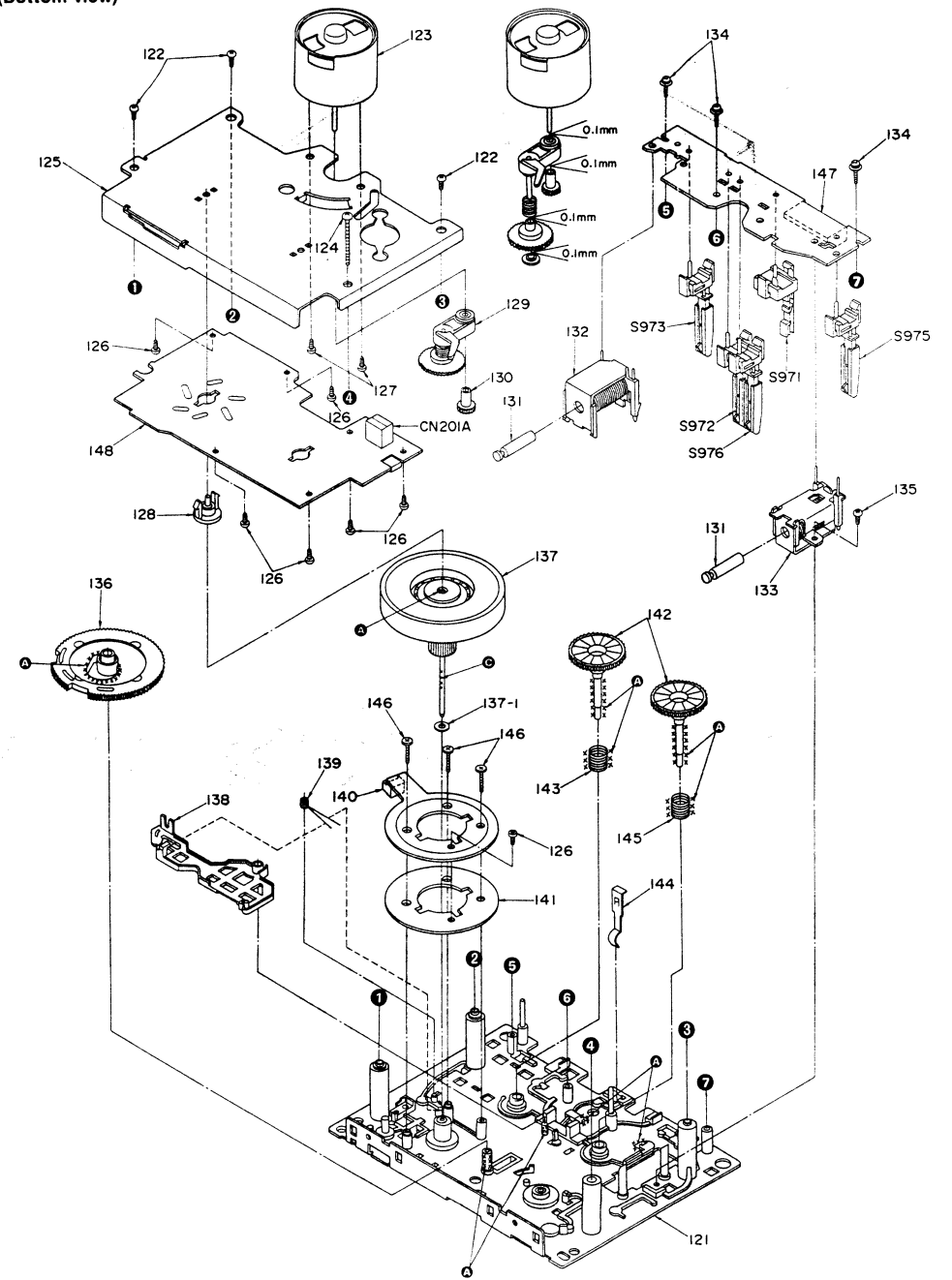

Note:  
When changing mechanism parts,  
apply the specified grease to areas  
marked "XX" as shown in the drawing.

Part No	Part Name	Part No.
A	FL0IL AK-152	SZZ0L18
G	FL0IL947P	RZZ0L02

## REPLACEMENT PARTS LIST

Ref. No.	Part No.	Part Name & Description	Remarks	Ref. No.	Part No.	Part Name & Description	Remarks
		MECHANISM PARTS LIST		148	REPO268A	STATER P. C. B. ASS'Y	
101	QHJ1361A	SCREW					
102	SJH96-1	E HEAD					
103	RHES2012A	SCREW					
104	RJHAC35GZAM	R/P HEAD					
105	QBC1278A	SPRING					
106	RHM2782A	SPACER					
107	RMD50132C	HEAD SPACER					
108	XTN2+5F	SCREW					
109	REX0075	LEAD WIRE BLOCK					
110	RXG0001	REEL TABLE					
111	RUW1392A	SPRING					
112	RMA0047B	HEAD BASE					
113	RXQ0078	MAIN ROD ASS'Y					
114	RMD012-2	EJECT ROD (L)					
115	RMD018-1	SPRING					
116	RUBS022	LEVER					
117	RMD020	SPRING					
118	RKL0007	BRAKE LEVER					
119	RUW1422A	SPRING					
120	RXP0004	PINCH ROLLER ARM					
120-1	RUW1402B	SPRING					
121	RFKRS8555E-K	CHASSIS ASS'Y					
122	XTN26-7J	SCREW					
123	MMH-6F4RA88	REEL MOTOR					
124	XTN26-26F	SCREW					
125	RMA0048A	FLYWHEEL PLATE					
126	XTN2+3F	SCREW					
127	XSN26-3	SCREW					
128	RMR0141	THRUST BEARING					
129	RXG0009	GEAR ASS'Y					
130	RDG0034	REEL MOTOR GEAR					
131	RUB4282	MOVING IRON CORE					
132	RSJ0003	SOLENOID					
133	RXQ0011	BRAKE SOLENOID					
134	XTW2+8S	SCREW					
135	XTN26-4F	SCREW					
136	RDC0030	MAIN GEAR					
137	RXF0008	FLYWHEEL					
137-1	RWU1392A	WASHER					
138	RML0037	LEVER					
139	RUW1472A	SPRING					
140	RJS2772A	CONNECTOR (2P)					
141	RMD0037	PG YOKE					
142	RXG0003	REEL TABLE GEAR					
143	RUQ1122A	SPRING					
144	RUS609Z	TAPE PRESSURE SPRING					
145	RUQ1112A	SPRING					
146	RHES2042A	SCREW					
147	RJS1172A	CONNECTOR (11P)					

# RESISTORS & CAPACITORS

Notes : \* Capacity value are in microfarads (uF) unless specified otherwise, P=Pico-farads (pF) F=Farads (F)  
 \* Resistance values are in ohms, unless specified otherwise, 1K=1,000 (OHM) . 1M=1,000k(OHM)

Ref. No.	Part No.	Values & Remarks	Ref. No.	Part No.	Values & Remarks	Ref. No.	Part No.	Values & Remarks
<b>RESISTORS</b>								
R1, 2	ERDS2TJ223T	1/4W 22K	R304, 305	ERDS2TJ100T	1/4W 10	R602	ERDS2TJ472T	1/4W 4.7K
R3, 4	ERDS2TJ473T	1/4W 47K	R306	ERDS2TJ471T	1/4W 470	R603	ERDS2TJ103T	1/4W 10K
R5, 6	ERDS2TJ102T	1/4W 1K	R307	ERDS2TJ222T	1/4W 2.2K	R604	ERDS2TJ472T	1/4W 4.7K Δ
R7, 8	ERDS2TJ225T	1/4W 2.2M	R308	ERDS2TJ472T	1/4W 4.7K	R605	ERDS1FVJ150T	1/2W 15 (E. ES, EG) Δ
R9, 10	ERDS2TJ104T	1/4W 100K	R311, 312	ERDS2TJ100T	1/4W 10	R606	ERD2FCVG150T	1/4W 15 (EB) Δ
R11, 12	ERDS2TJ183T	1/4W 18K	R313, 314	ERDS2TJ154T	1/4W 150K	R607, 608	ERDS1FVJ100T	1/2W 10 (E. ES, EG) Δ
R13, 14	ERDS2TJ101T	1/4W 100	R315, 316	ERDS2TJ153T	1/4W 15K	R609	ERD2FCVG100T	1/4W 10 (EB) Δ
R15, 16	ERDS2TJ820T	1/4W 82	R317	ERDS2TJ822T	1/4W 8.2K	R610	ERD2FCVG100T	1/4W 10 (EB) Δ
R17, 18	ERDS2TJ153T	1/4W 15K	R318	ERDS2TJ272T	1/4W 2.7K	R611, 612	ERDS1FVJ270T	1/2W 27 (E. ES, EG) Δ
R19, 20	ERDS2TJ103T	1/4W 10K	R319	ERDS2TJ102T	1/4W 1K	R613	ERD2FCVG270T	1/4W 27 (EB) Δ
R21, 22	ERDS2TJ564T	1/4W 560K	R320	ERDS2TJ332T	1/4W 3.3K	R614	ERDS2TJ222T	1/4W 2.2K Δ
R23, 24	ERDS2TJ682T	1/4W 6.8K	R321	ERDS1FVJ121T	1/2W 120 (E. ES, EG) Δ	R615	ERDS2TJ180T	1/4W 1.0 Δ
R25, 26	ERDS2TJ223T	1/4W 22K	R322	ERDS1FVJ561T	1/2W 560 (EB) Δ	R616	ERDS2TJ391T	1/4W 390 Δ
R27, 28	ERDS2TJ103T	1/4W 10K	R323	ERDS2TJ563T	1/4W 56K	R617, 618	ERDS2TJ221T	1/4W 220 (EB)
R29, 30	ERDS2TJ472T	1/4W 4.7K	R324	ERDS2TJ563T	1/4W 56K	R619, 620	ERQ16NKR15E	1/6W 0.15 (EB) Δ
R31, 32	ERDS2TJ392T	1/4W 3.9K	R325-327	ERDS1FVJ561T	1/2W 560 (EB)	R621	ERDS2TJ181T	1/4W 180 (EB)
R33, 34	ERDS2TJ102T	1/4W 1K	R401, 402	ERDS2TJ101T	1/4W 100	R622, 624	ERDS2TJ101T	1/4W 100 (EB)
R35, 36	ERDS2TJ820T	1/4W 82	R403, 404	ERDS2TJ272T	1/4W 2.7K	R625	ERDS2TJ181T	1/4W 180 (EB)
R39, 40	ERDS2TJ121T	1/4W 120	R405, 406	ERDS2TJ103T	1/4W 10K	R626, 627	ERDS2TJ101T	1/4W 100 (EB)
R41, 42	ERDS2TJ392T	1/4W 3.9K	R407, 408	ERDS2TJ242	1/4W 2.4K	R628	ERDS2TJ103T	1/4W 10K
R43, 44	ERDS2TJ152T	1/4W 1.5K	R409-412	ERDS2TJ684T	1/4W 680K	R629	ERDS2TJ472T	1/4W 4.7K Δ
R45, 46	ERDS2TJ272T	1/4W 2.7K	R413, 414	ERDS2TJ562T	1/4W 5.6K	R630	ERD2FCVG100T	1/4W 10 (EB) Δ
R47, 48	ERDS2TJ104T	1/4W 100K	R415, 416	ERDS2TJ102T	1/4W 1K	R631-636	ERDS2TJ221T	1/4W 220 (EB)
R49, 50	ERDS2TJ564T	1/4W 560K	R417, 418	ERDS2TJ332T	1/4W 3.3K	R637, 638	ERDS2TJ391T	1/4W 390 Δ
R51-56	ERDS2TJ223T	1/4W 22K	R419, 420	ERDS2TJ333T	1/4W 33K	R701	ERDS2TJ821T	1/4W 820
R57, 58	ERDS2TJ153T	1/4W 15K	R421-424	ERDS2TJ823T	1/4W 82K	R702	ERDS2TJ102T	1/4W 1K
R59, 60	ERDS2TJ182T	1/4W 1.8K	R425, 426	ERDS2TJ683T	1/4W 68K	R703	ERDS2TJ122T	1/4W 1.2K
R61, 62	ERDS2TJ333T	1/4W 33K	R427, 428	ERDS2TJ222T	1/4W 2.2K	R704	ERDS2TJ152T	1/4W 1.5K
R63, 64	ERDS2TJ472T	1/4W 4.7K	R429, 430	ERDS2TJ512	1/4W 5.1K	R705	ERDS2TJ182T	1/4W 1.8K
R65, 66	ERDS2TJ102T	1/4W 1K	R431, 432	ERDS2TJ242	1/4W 2.4K	R706	ERDS2TJ222T	1/4W 2.2K
R67, 68	ERDS2TJ223T	1/4W 22K	R551, 552	ERDS2TJ104T	1/4W 100K	R707	ERDS2TJ332T	1/4W 3.3K
R69, 70	ERDS2TJ472T	1/4W 4.7K	R553, 554	ERDS2TJ563T	1/4W 56K	R708	ERDS2TJ472T	1/4W 4.7K
R71, 72	ERDS2TJ561T	1/4W 560	R555, 556	ERDS2TJ104T	1/4W 100K	R709	ERDS2TJ682T	1/4W 6.8K
R201	ERJ6GEYJ333V	1/10W 33K	R557, 558	ERDS2TJ220T	1/4W 22	R710	ERDS2TJ123T	1/4W 12K
R202	ERJ6GEYJ683V	1/10W 68K	R559, 560	ERDS2TJ152T	1/4W 1.5K	R711	ERDS2TJ223T	1/4W 22K
R203-205	ERJ6GEYJ1R5V	1/10W 1.5	R561	ERDS2TJ102T	1/4W 1K	R712	ERDS2TJ821T	1/4W 820
R206	ERJ8GEYJ222V	1/8W 2.2K	R562	ERDS2TJ471T	1/4W 470	R713	ERDS2TJ102T	1/4W 1K
R207	ERJ6GEYJ182V	1/10W 1.8K	R563, 564	ERDS2TJ103T	1/4W 10K	R714	ERDS2TJ122T	1/4W 1.2K
R208	ERJ6GEYJ222V	1/10W 2.2K	R565	ERDS2TJ105T	1/4W 1M	R715	ERDS2TJ152T	1/4W 1.5K
R209-211	ERJ6GEYJ4R7V	1/10W 4.7	R568, 570	ERDS2TJ101T	1/4W 100	R716	ERDS2TJ182T	1/4W 1.8K
R212, 213	ERJ6GEYJ152V	1/10W 1.5K	R571	ERDS2TJ152T	1/4W 1.5K	R717	ERDS2TJ181T	1/4W 180
R214	ERJ6GEYJ822V	1/10W 8.2K	R572	ERDS2TJ102T	1/4W 1K	R718	ERDS2TJ331T	1/4W 330
R215	ERJ6GEYJ101V	1/10W 100	R573	ERDS2TJ560T	1/4W 56	R719, 720	ERDS2TJ180	1/4W 18
R216	ERJ8GEYJ222V	1/8W 2.2K	R574	ERDS2TJ220T	1/4W 22	R721, 722	ERDS2TJ330T	1/4W 33
R301	ERDS2TJ180T	1/4W 1.0	R575	ERDS2TJ681T	1/4W 680	R723, 724	ERDS2TJ100T	1/4W 10
R302, 303	ERDS2TJ183T	1/4W 18K	R576	ERDS2TJ681T	1/4W 680			
			R601	ERDS2TJ472T	1/4W 4.7K Δ			

Ref. No.	Part No.	Values & Remarks	Ref. No.	Part No.	Values & Remarks	Ref. No.	Part No.	Values & Remarks
R725, 726	ERDS2TJ102T	1/4W 1K	R958	ERDS2TJ103T	1/4W 10K	C39, 40	ECQB1H152JZ3	50V 1500P
R727, 728	ERDS2TJ332T	1/4W 3.3K	R959	ERDS2TJ152T	1/4W 1.5K	C41, 42	ECBT1H470J5	50V 47P
R901	ERDS2TJ105T	1/4W 1M	R960	ERDS2TJ472T	1/4W 4.7K	C43, 44	ECEA1K100B	16V 10U
R902	ERDS2TJ103T	1/4W 10K	R961	ERDS2TJ821T	1/4W 820	C45, 46	ECEA1EK4R7B	25V 4.7U
R903	ERDS2TJ471T	1/4W 470	R962	ERDS2TJ183T	1/4W 18K	C47, 48	ECEA1H8010B	50V 1U
R904	ERDS2TJ103T	1/4W 10K	R963	ERDS2TJ473T	1/4W 47K	C49, 50	ECEA1K100B	16V 10U
R905	ERDS2TJ182T	1/4W 1.8K	R964	ERDS2TJ392T	1/4W 3.9K	C51, 52	ECQV1H032F	50V 0.01U
R906	ERDS2TJ682T	1/4W 6.8K	R965	ERDS2TJ104T	1/4W 100K	C201	ECUV1E153MB	25V 0.015U
R907	ERDS2TJ103T	1/4W 10K	R970	ERDS2TJ222T	1/4W 2.2K	C202	ECUV1E104KB	25V 0.01U
R908	ERDS2TJ392T	1/4W 3.9K	R971	ERDS2TJ332T	1/4W 3.3K	C203, 204	ECEV1CA100R	16V 10U
R909	ERDS2TJ271T	1/4W 2.7K	R971A	ERDS2TJ271T	1/4W 2.7K	C205, 206	ECUV1E104KB	25V 0.01U
R910	ERDS2TJ103T	1/4W 10K	R972	ERDS2TJ472T	1/4W 4.7K	C209-211	ECEV1EN4R7R	25V 4.7U
R911	ERDS2TJ392T	1/4W 3.9K	R972A	ERDS2TJ183T	1/4W 18K	C212-214	ECUV1H1032FN	50V 0.01U
R912	ERDS2TJ272T	1/4W 2.7K	R973	ERDS2TJ682T	1/4W 6.8K	C215	ECUV1H472KB	50V 4700P
R913	ERDS2TJ561T	1/4W 56K	R973A	ERDS2TJ271T	1/4W 2.7K	C216	ECUV1E562K8N	25V 5600P
R914	ERDS2TJ102T	1/4W 1K	R974	ERDS2TJ123T	1/4W 12K	C217-219	ECUV1E104KB	25V 0.01U
R915	ERDS2TJ103T	1/4W 10K	R974A	ERDS2TJ183T	1/4W 18K	C301	ECQP1153JZ	100V 0.015U
R916	ERDS2TJ332T	1/4W 3.3K	R975	ERDS2TJ223T	1/4W 22K	C302	ECEA1EK4R7B	25V 4.7U
R917, 918	ERDS2TJ103T	1/4W 10K	R977	ERDS2TJ223T	1/4W 22K Δ	C303	ECKT1H932KB	50V 3900P
R919, 920	ERDS2TJ223T	1/4W 22K	R978	ERDS2TJ473T	1/4W 47K	C304, 305	ECKT1H222KB	50V 2200P
R922	ERDS2TJ472T	1/4W 4.7K	R979	ERDS2TJ272T	1/4W 2.7K	C306	ECKT1H682KB	50V 6800P
R923	ERDS2TJ152T	1/4W 1.5K	R980	ERDS2TJ472T	1/4W 4.7K	C310	ECKD1H472KB	50V 4700P
R924	ERDS2TJ223T	1/4W 22K Δ	R981	ERDS2TJ392T	1/4W 3.9K	C311	ECEA1U101B	10V 100U
R925	ERDS2TJ821T	1/4W 820	R982	ERDS2TJ223T	1/4W 22K	C312	ECKT1H032F	50V 0.01U
R926	ERDS2TJ223T	1/4W 22K Δ	R983	ERDS2TJ103T	1/4W 10K	C313, 314	ECKT1H223Z	50V 0.022U
R927	ERDS2TJ821T	1/4W 820	R984	ERDS2TJ472T	1/4W 4.7K (EB)	C315, 316	ECBT1H821KB5	50V 820P
R928	ERG1SJ150	1W 15 Δ	R985	ERDS2TJ222T	1/4W 2.2K (EB)	C317, 318	ECBT1H121KB5	50V 120P
R929	ERG1SJ180E	1W 18 Δ	R986	ERDS2TJ332T	1/4W 3.3K (EB)	C319, 320	ECQV1H563JZ3	50V 0.056U
R930	ERDS2TJ223T	1/4W 22K Δ	R987	ERDS2TJ822T	1/4W 8.2K	C321, 322	ECQB1H223JZ3	50V 0.022U
R931	ERDS2TJ821T	1/4W 820	R988	ERDS2TJ473T	1/4W 47K	C323, 324	ECQB1H032JZ3	50V 0.01U
R932	ERDS2TJ472T	1/4W 4.7K (EB)	R989	ERDS2TJ822T	1/4W 8.2K	C325, 326	ECKT1H222KB	50V 1200P
R932	ERDS2TJ103T	1/4W 10K (E. ES, EG)	R990	ERDS2TJ473T	1/4W 47K	C328	ECBT1H80J5	50V 18P
R933	ERDS2TJ472T	1/4W 4.7K				C329	ECEA1EK100B	25V 10U
R935	ERDS2TJ682T	1/4W 6.8K				C330	ECKT1H032F	50V 0.01U Δ
R936	ERDS2TJ223T	1/4W 22K				C331	ECBT1H180J5	50V 18P
R938	ERDS2TJ682T	1/4W 6.8K				C401, 402	ECBT1H820KB5	50V 82P
R939	ERDS2TJ223T	1/4W 22K				C403, 404	ECEA1EK4R7B	25V 4.7U
R940, 941	ERDS2TJ562T	1/4W 5.6K				C405, 406	ECKT1H122KB	50V 1200P
R942	ERDS2TJ821T	1/4W 820				C407, 408	ECKT1H152KB	50V 1500P
R943	ERDS2TJ223T	1/4W 22K				C409, 410	ECQV1H724JZ3	50V 4700P
R944, 945	ERDS1FVJ180T	1/2W 18 Δ				C411, 412	ECEA1CK100B	16V 10U
R946	ERDS2TJ102T	1/4W 1K				C413, 414	ECQV1H473JZ3	50V 0.047U
R947, 948	ERDS2TJ103T	1/4W 10K				C415, 416	ECQV1H224JZ3	50V 0.22U
R949	ERDS2TJ472T	1/4W 4.7K				C417-420	ECEA1HR68B	50V 0.68U
R950	ERDS2TJ821T	1/4W 820				C421, 422	ECQV1H1032JZ3	50V 0.01U
R951	ERDS2TJ101T	1/4W 100				C423, 424	ECQV1H473JZ3	50V 0.047U
R952	ERDS2TJ823T	1/4W 82K				C425, 426	ECEA1CK100B	16V 10U
R953	ERDS2TJ393T	1/4W 39K				C427, 28	ECQB1H822JZ3	50V 8200P
R954	ERDS2TJ472T	1/4W 4.7K				C429, 430	ECQV1H563JZ3	50V 0.056U
R955								

Ref. No.	Part No.	Values & Remarks	Ref. No.	Part No.	Values & Remarks
C555	ECKT1H103ZF	50V 0.01U	C619, 620	ECKT1H103ZF	50V 0.01U Δ
C556	ECEA1CK100B	16V 10U	C621	ECKT2H682PEL	500V 6800P Δ
C557	ECEA1EK4R7B	25V 4.7U	C701	ECKT1H223ZF	50V 0.022U
C558	ECEA1HND10B	50V 1U	C702, 703	ECKT1H103ZF	50V 0.01U
C559-561	ECBT1C103MS5	16V 0.01U	C901	ECEAJU222B	6.3V 2200U
C563, 564	ECEAJU101B	6.3V 100U	C902	ECKT1H103ZF	50V 0.01U
C567	ECEA1VK100B	35V 10U	C903	ECEA1HND10B	50V 1U
C568	ECEA1VK100B	35V 10U	C904	ECEA1EK4R7B	25V 4.7U
C601	ECKT2H682PEL	500V 6800P	C905	ECKT1H103ZF	50V 0.01U
C602, 603	ECEA1EU222E	25V 2200U Δ	C906	ECEA1CN100SB	16V 10U
C604, 605	ECKT1H103ZF	50V 0.01U	C907	ECEA1HND10B	50V 1U
C606, 607	ECEA1AU221B	10V 220U	C908	ECKT1H103ZF	50V 0.01U
C608, 609	ECKT1H103ZF	50V 0.01U	C909	ECQB1H822J3	50V 8200P
C610, 611	ECEA1AU102B	10V 1000U	C910	ECEA1CK100B	16V 10U
C612	ECEA1EU222E	25V 2200U Δ	C911	ECBT1H470J5	50V 47P
C613	ECKT1H103ZF	50V 0.01U	C912	ECEA1HND10B	50V 1U
C615	ECEA1EK100B	25V 10U	C913	ECKT1H103ZF	50V 0.01U
C617	ECEA1HM470B	50V 47U	C914	ECEA1EK4R7B	25V 4.7U
C618	ECKT1H103ZF	50V 0.01U	C915	ECEAJU101B	6.3V 100U
C619, 620	ECKT1H103ZF	50V 0.01U Δ	C916	ECKT1H103ZF	50V 0.01U
C621	ECKT2H682PEL	500V 6800P Δ	C917	ECEA1HND10B	50V 1U (EB)
C701	ECKT1H223ZF	50V 0.022U	C918	ECKT1H103ZF	50V 0.01U

Cassette Deck

DEUTSCH

RS-B555  
RS-B655

MESSUNGEN UND EINSTELL METHODEN

Tonkopf-Azimuteinstellung

1. Spielen Sie auf dem Testband (QZZCFM) den Teil für die Azimuteinstellung (8kHz, -20dB) ab. Drehen Sie die Azimuteinstellschraube so lange, bis die Abgaben des L-K und R-K den Höchstwert erreichen, und die Lissajossge wellenfigur sich, wie abgebildet, 0 Grad nähert.
2. Nehmen Sie denselben Einstellvorgang in der Wiedergabestellung vor.

Anmerkung:

When L-K and R-K nicht auf demselben Punkt ihren Höchstwert erreichen, stellen Sie beide Kanäle auf den jeweiligen Höchstwert und gleichen dann aus.

Prüfung des Pegelunterschiedes bei Vorwärts- und Rückwärtsdrehung

3. Den Abschnitt für Verstärkungseinstellung (315Hz, 0dB) des Prüfbandes (QZZCFM) wiedergeben und sicherstellen, daß der Pegelunterschied bei Vorwärts- und Rückwärtsdrehung kleiner als 1dB ist.
4. Nach der Einstellung Schrauben-Sicherungsmittel an die Azimuth-Einstellschraube geben.

Einstellung der Wiedergabeverstärkungsregelung

1. Spielen Sie auf dem Testband (QZZCFM) den Teil für die Einstellung der Verstärkungsregelung (315Hz, 0dB) ab.
2. Stellen Sie VR1 (L-K) [VR2 (R-K)] so ein, daß die Abgabe den Normwert erfüllt.

Wiedergabefrequenzaang

1. Spielen Sie auf dem Testband (QZZCFM) den Teil für den Frequenzgang (315Hz, 12,5kHz~63Hz, -20dB) ab.
2. Achten Sie darauf, daß der Frequenzgang für beide Kanäle (L-K, R-K) in dem in Abb.5 gezeigten Bereich liegt.

Wechselstrom-Vorndgnetisierungseinstellung

1. Das unbespielte Metalltestband (QZZCRZ) einlegen, und das Gerät auf Aufnahme Schalten.
2. L1 (L-CH) (L2 (R-CH)) so einstellen, daß die Ausgangsspannung zwischen TP1 (TP2) und GND geringer als der Minimalwert ist.

PACKING  
(Parts list on page 36.)

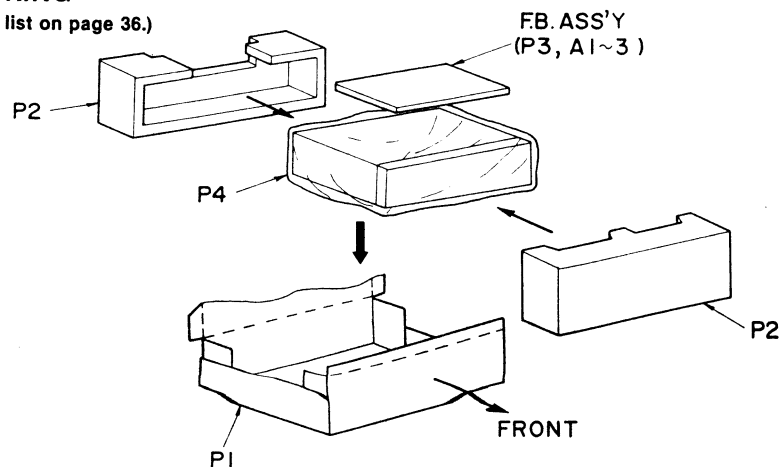

# Service Manual

Cassette Deck  
RS-B655

Supplement

Dolby NR-Equipped  
Stereo Cassette Deck

Color

(K)...Black Type

**DOLBY B-C NR HX PRO**

\*HX Pro headroom extension originated by Bang Olufsen and manufactured under license from Dolby Laboratories Licensing Corporation. "DOLBY", the double-D symbol, and "HX PRO" are trademarks of Dolby Laboratories Licensing Corporation.

#### Area

Country Code	Area	Color
(E, E5)	Continental Europe.	(K)
(EB)	Great Britain.	
(EG)	F.R. Germany & Italy.	

Please file and use this supplement manual together with the service manual for Model No. RS-B655, Order No. AD8907232C2.

#### Note:

- This supplement has been issued to correct an error in the "Replacement Parts List" on page 36.

## DELETION

### ■ REPLACEMENT PARTS LIST (Page 36 of service manual.)

#### Note:

- Please remove the MECHANISM UNIT ASS'Y and the PRINTED CIRCUIT BOARD ASS'Y from the parts list because they are out of object in the replacement parts lists.

Ref. No.	Change of Part No.	Part Name & Description	Remarks
	ORIGINAL		
<b>MECHANISM UNIT</b>			
MECH1	RAA0802	MECHANISM ASS'Y	Deletion
<b>PRINTED CIRCUIT BOARDS</b>			
PWB1 (E, E5, EG)	REP0306A	MAIN P.C.B. ASS'Y	Deletion
PWB1 (EB)	REP0306B	MAIN P.C.B. ASS'Y	Deletion
PWB2	REP0307A	SUB P.C.B. ASS'Y	Deletion

#### Gesamtfrequenzgang

- Legen Sie das normale Leertestband (QZZCRA) ein und stellen das Gerät auf Aufnahme-/Pause-Betrieb.
- Geben Sie über einen Lautstärkereglер ein Bezugseingabesignal (1 kHz, -24 dB) ein.
- Stellen Sie das Signal auf 20 dB und justieren die Frequenz von 50 Hz~10 kHz.
- Nehmen Sie das Wobbelnsignal auf.
- Geben Sie das aufgenommene Signal wieder und achten darauf, daß dieses sich im Vergleich zur Bezugsfrequenz (1 kHz) in dem in Abb. 8 aufgezeichneten Bereich befindet.
- Sollte das Signal nicht im Normbereich liegen, justieren Sie VR301 (L-K) und VR302 (R-K), so daß der Frequenzpegel mit der Norm übereinstimmt.
- Wiederholen Sie die Schritte 2~6 und verwenden das CrO<sub>2</sub> Band (QZZCRX) und das Metallband (QZZCRZ). Der Frequenzbereich wird auf 12.5 kHz (50 Hz~12.5 kHz) angehoben.
- Achten Sie darauf, daß sich der Frequenzpegel in dem in Abb. 9 aufgezeigten Bereich befindet.

#### Einstellung der Gesamtverstärkungsregelung

- Legen Sie das normale Leertestband (QZZCRA) ein und stellen das Gerät auf Aufnahme-/Betrieb.
- Legen Sie ein Bezugseingabesignal (1 kHz, -24 dB) an. Stellen Sie das Ausgangssignal auf einen Pegel von 0.4 V ein.
- Nehmen Sie das Eingabesignal auf.
- Geben Sie das in Schritt 3 oben aufgenommene Signal wieder und achten Sie darauf, daß das Ausgangssignal mit dem Normwert übereinstimmt.
- Sollte der Wert nicht innerhalb der Norm liegen, justieren Sie VR3 (L-K) und VR4 (R-K).
- Wiederholen Sie die Schritte 2~5 von oben so lange, bis das Ausgangssignal im Normbereich liegt.

# Technics

Matsushita Electric Industrial Co., Ltd.  
Central P.O. Box 288, Osaka 530-91, Japan

Printed in Japan  
K890908250HK

## FRANÇAIS

## METHODES DES MESURES ET REGLAGES

## Reglage Azimutal de la tete

1. Faire jouer la portion du réglage de l'azimuth (8kHz, -20dB) de la bande d'essai (QZZCFM). Ajuster la vis de la mise au point azimutale jusqu'à ce que les sorties du canal de gauche et du canal de droite soient maximisées et que la forme d'onde de Lissajous, comme il est illustré, approche de 0 degré.

## Nota:

Si le canal de gauche et canal de droite ne sont pas maximisés au même point, régler le point où les niveaux de chaque canal sont maximisés et égaux.

2. Effectuer le même réglage sur le mode d'audition.

## Vérification de la différence de niveau pour les deux sens de rotation

3. Introduire une bande métal vierge prévue pour les essais (QZZCPZ) et vérifier que la différence de niveau pour les deux sens de rotation est inférieure à 1dB.
4. Après cela, mettre une goutte de vernis de blocage sur la vis de réglage de l'azimut.

## Reglage de L'amplification de Lecture

1. Faire jouer la partie réglée de l'amplification (315Hz, 0dB) de la bande d'essai (QZZCFM).

2. Régler la platine 1: VR1 (canal de gauche) [VR2 (canal de droite)] de telle sorte que la sortie soit en deçà de la valeur standard.

## Reponse en Frequence de la Lecture

1. Faire jouer la partie de la réponse en fréquence (315Hz, 12.5kHz, -63Hz, -20dB) de la bande d'essai (QZZCFM).

2. S'assurer que la réponse en fréquence soit en deçà de la plage montrée dans la Fig. 5, à la fois pour le canal de gauche et le canal de droite.

## Réglage du bouchon de polarisation

1. Introduire la cassette d'essai vierge (QZZCRZ) et régler l'appareil pour l'enregistrement.
2. Régler L1 (L-CH) et L2 (R-CH) de sorte que la tension entre TP1 (TP2) et la masse (GND) soit inférieure à la valeur minimale.

## Reponse en Frequence Totale

1. Introduire la bande d'essai vierge normale (QZZCRA) et régler l'appareil sur le mode d'intermission d'un disque.
2. Appliquer un signal d'entrée de référence (1kHz, -24dB) par l'intermédiaire d'un atténuateur.
3. Diminuer le signal de 20dB et régler la fréquence de 50Hz~10kHz.
4. Enregistrer le balayage de fréquence.
5. Faire jouer le signal enregistré et s'assurer qu'il soit en deçà de la plage montrée à la Fig. 8 en comparaison à la fréquence de référence (1kHz).

6. S'il n'est pas en deçà de la plage standard, régler VR301 (canal de gauche) et VR302 (canal de droite) de telle sorte que le niveau de fréquence soit en deçà de la plage standard.
7. Répéter les étapes 2~6 ci-dessus en utilisant la bande CrO<sub>2</sub> (QZZCRX) et la bande métallisée (QZZCRZ) en augmentant la plage de fréquence à 12.5kHz (50Hz~12.5kHz).
8. S'assurer que le niveau soit en deçà de la plage montrée à la Fig. 9.

## Reglage de L'amplification Totale

1. Introduire la bande d'essai vierge normale (QZZCRA) et régler l'appareil sur le mode d'intermission d'un disque.
2. Appliquer un signal d'entrée de référence (1kHz, -24dB). Diminuer la sortie de telle sorte que son niveau devienne de 0.4V.
3. Enregistrer ce signal d'entrée.

4. Faire jouer le signal enregistré à l'étape 3 ci-dessus, et s'assurer que la sortie en deçà de la valeur standard.
5. Si elle n'est pas en deçà de la valeur standard, régler VR3 (canal de gauche) et VR4 (canal de droite).
6. Répéter les étapes 2~5 ci-dessus jusqu'à ce que la sortie soit en deçà de la valeur standard.



**ESPAÑOL**

**METODOS DE AJUSTE Y MEDIDA**

<p><b>Ajuste Azimutal de Cabeza</b></p> <ol style="list-style-type: none"> <li>1. Reproducir la porción de ajuste azimutal (8kHz, -20dB) de la cinta de prueba (QZZCFM). Variar el tornillo de ajuste azimutal hasta que las salidas del CH-I y CH-D se maximicen y forma de onda de lissajous, como ilustrado, se acerque a grado 0.</li> </ol> <p><b>Nota:</b> Si CH-I y CH-D no son maximizados en el mismo punto, ajustar al punto donde los niveles de cada canal sean maximizados e igualados.</p> <ol style="list-style-type: none"> <li>2. Efectuar el mismo ajuste en la modalidad de reproducción.</li> </ol>	<p><b>Comprobación de la diferencia de nivel de giro hacia adelante y hacia atrás</b></p> <ol style="list-style-type: none"> <li>3. Reproduzca la parte del ajuste de ganancia (315Hz, 0dB) de la cinta de prueba (QZZCFM) y luego asegúrese de que la diferencia de nivel de giro hacia adelante y hacia atrás sea menor que 1 dB.</li> <li>4. Después del ajuste, aplique pintura de fijación al tornillo de ajuste del azimut.</li> </ol>
<p><b>Ajuste de Ganancia de Reproduccion</b></p> <ol style="list-style-type: none"> <li>1. Reproducir la porción ajustada de ganancia (315Hz, 0dB) de la cinta de prueba (QZZCFM).</li> </ol>	<ol style="list-style-type: none"> <li>2. Ajustar la Platina 1: VR1 (CH-I) [[VR2 (CH-D)]] de manera que la salida esté dentro del valor estándar.</li> </ol>
<p><b>Respuesta de Frecuencia de Reproduccion</b></p> <ol style="list-style-type: none"> <li>1. Reproducir la parte de respuesta de frecuencia de reproducción (315Hz, 12.5kHz~63Hz, -20dB) de la cinta de prueba (QZZCFM).</li> </ol>	<ol style="list-style-type: none"> <li>2. Asegurarse de que la respuesta de frecuencia esté dentro de la gama mostrada en la Fig. 5 para ambos CH-I y CH-D.</li> </ol>
<p><b>Ajuste del Circuito Trampa de Polarizacion</b></p> <ol style="list-style-type: none"> <li>1. Introduzca la cinta virgen de metal (QZZCRZ) para pruebas y ponga el aparato en el modo de grabación.</li> <li>2. Ajuste L1 (canal izq.) ((L2 (canal der.)) de manera que la tensión de salida entre TP1 (TP2) y GND (Tierra) sea menor que el valor mínimo.</li> </ol>	

<p><b>Respuesta de Frecuencia Total</b></p> <ol style="list-style-type: none"> <li>1. Poner una cinta virgen normal (QZZCRA) y poner la unidad en la modalidad de Pausa de Grabación.</li> <li>2. Aplicar la señal de entrada de referencia (1kHz, -24dB) a través de un atenuador.</li> <li>3. Atenuar la señal por 20dB y ajustar la frecuencia de 50Hz~10kHz.</li> <li>4. Grabar el barrido de frecuencia.</li> <li>5. Reproducir la señal grabada y asegurarse de que esté dentro de la gama mostrada en la Fig. 8 en comparación con la frecuencia de referencia (1kHz).</li> <li>6. Si no está dentro de la gama de frecuencia, ajustar VR301 (CH-I) y VR302 (CH-D) de manera que el nivel de frecuencia esté dentro de la gama estándar.</li> <li>7. Repetir los pasos 2~8 de arriba utilizando la cinta CrO<sub>2</sub> (QZZCRX) y la cinta metálica (QZZCRZ) incrementando la gama de frecuencia a 12.5kHz (50Hz~12.5kHz).</li> <li>8. Asegurarse de que el nivel esté dentro de la gama mostrada en la Fig. 9.</li> </ol>	
<p><b>Ajuste de Ganancia Total</b></p> <ol style="list-style-type: none"> <li>1. Insertar la cinta de prueba en blanco normal (QZZCRA) y poner la unidad en modalidad de pausa de Grabación.</li> <li>2. Aplicar la señal de entrada de referencia (1kHz, -24dB). Atenuar la salida de manera que su nivel se haga 0.4V.</li> <li>3. Grabar la señal de entrada.</li> <li>4. Reproducir la señal grabada en el paso 3 de arriba y asegurarse de que la salida esté dentro del valor estándar.</li> <li>5. Si no está dentro del valor estándar, ajustar VR3 (CH-I) y VR4 (CH-D).</li> <li>6. Repetir el paso 2~5 de arriba hasta que la salida esté dentro del valor estándar.</li> </ol>	