

Limestone

Datasheet



Revision history

| Date | Doc. Rev. | Limestone PDA Baseboard | Changes |
|------------|-----------|-------------------------|--|
| 05-June-09 | Rev 1.0 | V2.0 | Creation of this document |
| 08-June-09 | Rev 1.1 | V2.0 | Minor clarifications |
| 24-July-09 | Rev 1.2 | V2.0 | Added connector references |
| 27-July-09 | Rev 1.3 | V2.0 | Minor clarifications |
| 08-Sept-09 | Rev 1.4 | V2.0 | Added rated current for extension connector |
| 23-Oct-09 | Rev 1.5 | V2.0 | Added clarifications on architecture |
| 03-Dec-10 | Rev 1.6 | V2.0 | Added clarifications about on-board fuse Changed Disclaimer |



Contents

| | |
|---|-----------|
| 1. Introduction | 4 |
| 1.1 Hardware | 4 |
| 1.2 Software | 4 |
| 1.2.1 Windows CE | 4 |
| 1.3 Features | 5 |
| 1.4 Reference Documents | 6 |
| 1.4.1 Marvell PXA320 Processor Based on Intel XScale Technology | 6 |
| 1.4.2 Toradex Colibri Module PXA320 | 6 |
| 1.4.3 WM9713G Audio and Touch Screen Controller | 6 |
| 2. Architecture Overview | 7 |
| 2.1 PXA320 Processor | 7 |
| 2.1.1 Power Input and Switching | 7 |
| 2.1.2 Battery Charger and Fuel Gauge | 8 |
| 2.1.3 Power Converters | 8 |
| 2.1.4 SD-Card Slot | 8 |
| 2.1.5 LCD Interface | 9 |
| 2.1.6 Optional RF Shielding Box | 9 |
| 3. Connectors and Switches | 10 |
| 3.1 Physical Locations | 10 |
| 3.2 Connector and Switch Description | 10 |
| 3.2.1 On/Off Switch S1 | 10 |
| 3.2.2 DC-Input X6 | 11 |
| 3.2.3 USB Micro A/B (Host/Device) X58 | 11 |
| 3.2.4 Head-Set Jag X61 | 11 |
| 3.2.5 Battery Pack X12 | 11 |
| 3.2.6 MMC/SD Card Slot X11 | 11 |
| 3.2.7 Extension Connector (X2) | 12 |
| 3.2.8 Microphone X1 | 14 |
| 3.2.9 Speaker X4 | 14 |
| 3.2.10 JTAG Connector (X2) | 14 |
| 3.3 Signal Description | 15 |
| 3.3.1 PACK+ | 15 |
| 3.3.2 DC_IN_SUPPLY+ | 15 |
| 3.3.3 CELL- | 15 |
| 3.3.4 BATT+ | 15 |
| 3.3.5 SUPPLY+ | 15 |
| 3.3.6 TS | 15 |
| 3.3.7 +3.3V | 15 |
| 3.3.8 USB5V | 15 |
| 3.3.9 GND | 15 |
| 3.3.10 PUSH_IN | 15 |
| 3.3.11 GPIOx | 15 |
| 3.3.12 EXT_WAKEUPx | 16 |
| 3.3.13 USBH1_x | 16 |
| 3.3.14 Audio and Touch Signals | 16 |
| 3.3.15 RESET_EXT# | 16 |
| 3.3.16 RESET_OUT# | 16 |
| 3.3.17 SYS_EN | 17 |
| 3.3.18 I2C Serial Interface | 17 |
| 3.3.19 PXA320 Processor Bus | 17 |
| 4. Technical Specifications | 18 |
| 4.1 Electrical Characteristics | 18 |



| | | |
|-----------|----------------------------------|-----------|
| 4.2 | Mechanical Characteristics | 18 |
| 4.3 | Temperature Range | 18 |
| 4.4 | RoHS Compliance | 18 |
| 5. | Customization | 19 |



1. Introduction

1.1 Hardware

The Limestone PDA Baseboard is based on the Marvell Xscale® PXA320 processor and runs at up to 806 MHz. It serves as the main part inside the Limestone PDA Kit and features all basic infrastructures necessary to build a customized handheld computer or PDA. In contrast to any available consumer device, the Limestone PDA Baseboard was specifically designed to meet industrial requirements. Components were selected from embedded product lines to guarantee the longest possible product life-time.

A rich board-to-board extension interface offers plenty of options to add an extension board with customer-specific electronics, such as WLAN, Bluetooth, GSM, GPRS, GPS, Camera, RFID / Barcode Scanners or even specific sensors to measure acceleration or orientation.

Beside 1GB of Flash memory and 128MB RAM, there are a battery charging / monitoring circuitry, high quality audio, USB Host/Device (shared), as well as an SD/MMC slot already implemented on the Limestone PDA Baseboard. The interface to the customer specific extension board offers LCD, SPI, I2C, UART, additional SD interface, Audio in/out, CIF, USB host and many general purpose I/Os.

1.2 Software

The Limestone PDA Baseboard is shipped with a preinstalled WinCE image with WinCE Core license. Other OS like Embedded Linux or Google Android are available from third-party companies. Visit our website for more information: <http://www.toradex.com>

1.2.1 Windows CE

The Limestone PDA Baseboard is shipped with a Windows CE 6.0 core license. The license is valid for the preinstalled WinCE 5.0 or the WinCE 6.0 image which are both supported by Toradex. All WinCE images contain drivers for the most common interfaces and are easily customizable by registry settings to adapt to specific hardware. For more information about the WinCE image see: <http://files.toradex.com/Colibri/WinCE/>



1.3 Features

CPU

Marvell PXA320 806 MHz

Memory

128 Mbyte of DDR SDRAM (32 Bit)

1Gbyte of NAND FLASH (8 Bit)

Power Supplies

5VDC

Li-Ion Battery

On-Board Features

Li-ion/Li-Polymer Battery Charger

Fuel Gauge

High Quality Audio I/O (16 Bit stereo)

USB Host/Device

MIC/Line Out

On/Off Push-Button

SD/MMC Slot

Optional RF Shielding Box (not mounted by default)

Extension Connector

TTL LCD (SVGA)

Touch Screen (4-wire)

Digital (PCM)/Analog Audio I/O

Keypad Interface

Camera Interface

SD/MMC (2nd Slot)

USB Host

3x UART

SPI

I2C

GPIOs

Processor Bus

Reset In/Out - System Enable

On/Off Signal

Power Supplies

Supported Operating Systems

Toradex Support:

Windows CE 5.0

Windows CE 6.0

Third Party Support:

Linux

Android



1.4 Reference Documents

For detailed technical information about the Limestone PDA Baseboard components, please refer also to the documents listed below.

1.4.1 Marvell PXA320 Processor Based on Intel XScale Technology

The datasheets and other technical documents about the PXA320 processor are available on the Marvell web page (NDA required).

http://www.marvell.com/products/cellular/application/PXA3xx_series.jsp

1.4.2 Toradex Colibri Module PXA320

http://www.toradex.com/@api/deki/files/631/=Colibri_PXA320_Datasheet.pdf

1.4.3 WM9713G Audio and Touch Screen Controller

<http://www.wolfsonmicro.com>



2. Architecture Overview

The Limestone PDA Kit has been designed as a platform that allows to easily build a customized mobile device. It consists of several individual components, which can either be purchased from Toradex or designed by the customer, and therefore allows the designer to concentrate on his core competences.

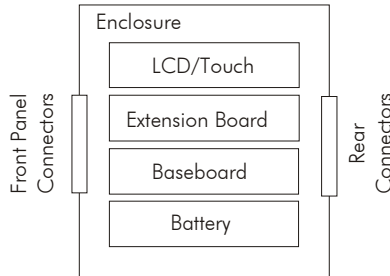

Fig. 1: Limestone PDA Kit System Components

The heart of the device is the Limestone PDA Baseboard. It contains the PXA320 processor and the entire basic infrastructure around it. Customization is done by adding required components on the Extension Board, if necessary.

2.1 PXA320 Processor

The Limestone PDA Baseboard is based on the Marvell XScale® PXA320 processor running at up to 806 MHz. The operating system and a large flash file system are stored in a 1 GB NAND Flash device.

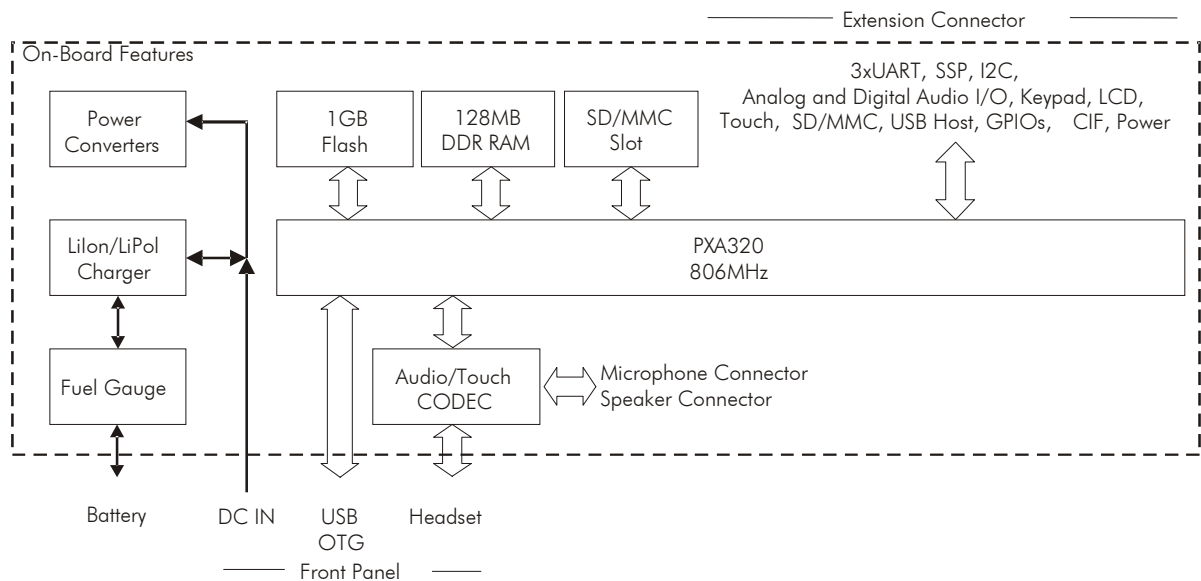

Fig. 2: Limestone PDA Baseboard PXA320.

2.1.1 Power Input and Switching

The Limestone PDA baseboard has a powering architecture designed for portable applications. Two power sources are available: a 1 Cell Li or Li-Poly battery and/or a direct DC jack 5V input.

When available, the DC input voltage is used to charge the battery and power the Limestone Baseboard. When the DC input voltage is unavailable the whole Limestone board is powered by the battery. A dedicated battery management hardware including a charger and a fuel gauge handles the switching of the power sources (SUPPLY+).

A direct supply to the battery (BATT+) is also provided and routed to the Limestone extension connector.



The supplies from the battery or DC input are routed through a second switching stage controlled by a push button that acts as a global on/off switch for the Limestone baseboard.

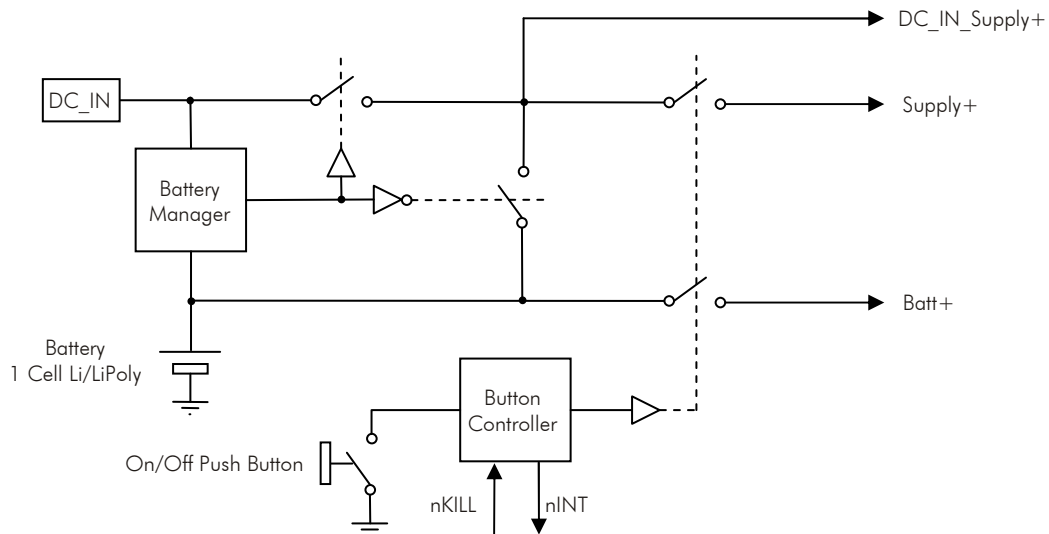

Fig. 3: Limestone PDA Baseboard Power Switching Architecture.

2.1.2 Battery Charger and Fuel Gauge

The battery management hardware supports any single cell Li-Ion and Li-Polymer rechargeable battery (nominal cell voltage 3.6/3.7V). The maximum charging current is set to 1.45 amps. Please make sure that your battery is able to bear a charging current of up to 1.45 amps!

The fuel gauge monitors current flowing into and out of the battery, and therefore provides accurate data about the remaining battery capacity. This data can be read through I2C from the PXA320 processor, or from any device on the extension board.

The battery is charged whenever DC power is applied. DC power can be applied and removed at any time, also during operation of the device. If DC power is present, the system draws its operating current from there. This allows controlling the charging current independent of the systems momentary power consumption. The external DC power supply must be able to supply the sum of the maximum charging current and the maximum current drawn by the system.

2.1.3 Power Converters

The power converters generate all necessary power rails from the DC input voltage or the battery voltage (SUPPLY+).

Two +3.3V and USB5V supplies generated by these power converters are available on the Limestone Baseboard extension connector and respectively have maximum current limits of 2.5A and 500mA. Note that these values are limited by the DC/DC converters and that a part of these currents (depending of the application) can be used on the Limestone Baseboard itself! (+3.3V powers most of the digital part of the Limestone. USB5V can be used on the Limestone Baseboard USB OTG port)

The extension connector imposes a second limitation of 0.3A per connected pin. The +3.3V supply has 3 connections to the extension connector limiting current to 0.9A while the USB5V has two enabling to draw the full 500mA (if no current is drawn on the Limestone Baseboard USB port).

2.1.4 SD-Card Slot

One SD-Card slot is assembled on the Limestone PDA Baseboard by default. It is possible to mount a second slot in parallel on the custom extension board, as the necessary signals are available on the board-to-board extension connector.



2.1.5 LCD Interface

The Marvell XScale® PXA320 processor of the Limestone Baseboard has its own integrated LCD driver. Toradex offers a software configuration tool that accommodates almost all configurations up to 800x600 (SVGA) resolutions and up to 18 bits per pixel (Note that higher resolutions up to 1024x768 (XGA) could be possible but might induce performance losses).

Due to the vast array of display solutions available and of application specificities, it was decided not to include a dedicated display interface on the Limestone Baseboard.

The PXA320 LCD controller signals are available as alternate functions of specific GPIOs that are available on the extension connector X2 of the Limestone Baseboard.

Alternate functions of GPIOs and the LCD controller are described respectively in volume 1 and 3 of the PXA3xx datasheet available at http://www.marvell.com/products/cellular/application/PXA3xx_series.jsp.

2.1.6 Optional RF Shielding Box

It is possible to assemble a dedicated RF Shielding Box on the Limestone PDA Baseboard. This is not done by default. Please contact Toradex for more information.



3. Connectors and Switches

3.1 Physical Locations

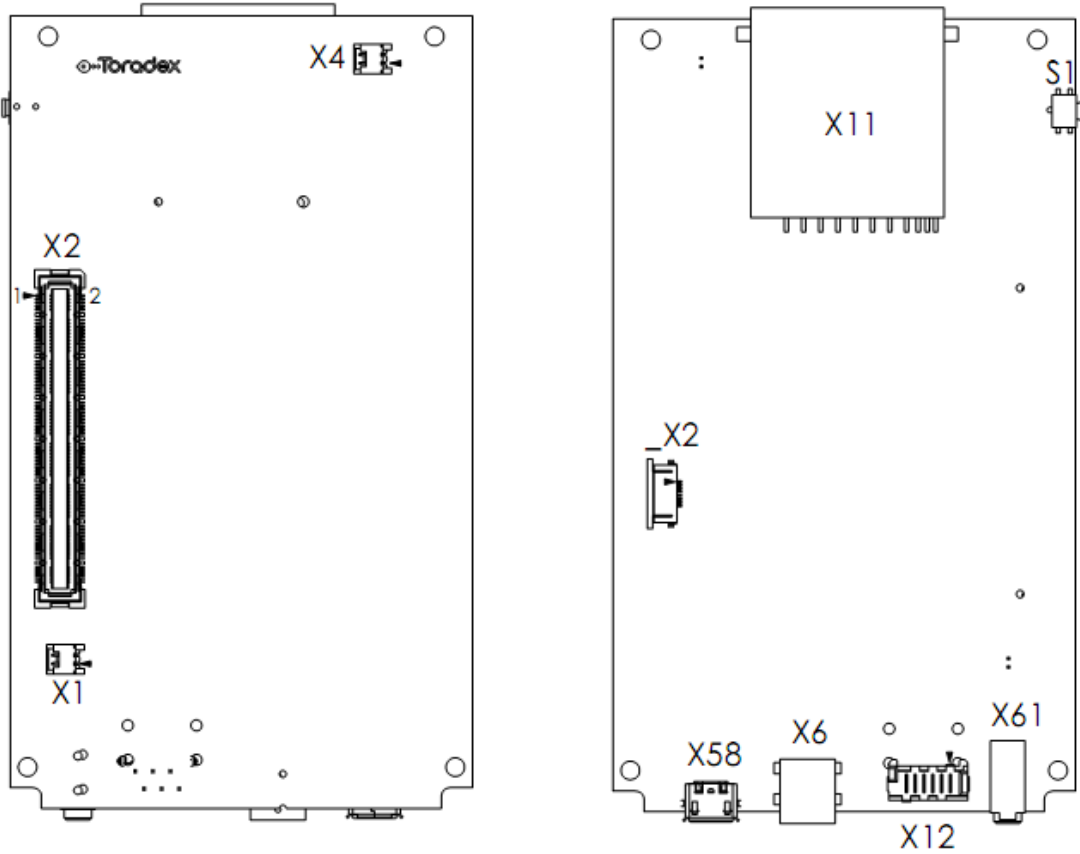

Fig. 4: Connector designator and location.

3.2 Connector and Switch Description

The signals are described in the Signal Description section below.

3.2.1 On/Off Switch S1

The On/Off Switch is a push button coupled to a controller that filters undesired switch operations and provides processor interface (processor triggered turn-off events). The On and Off push time to trigger an event are set by capacitors to 0.3 and 2.1 seconds respectively, and hence not configurable by software.

Note that the button input of the controller is also routed to the extension connector of the Limestone Baseboard to enable custom on/off solutions on an extension board.

The interface to the PXA320 processor consists of the following:

| Signal Name | Function Name | Description |
|-------------|--------------------|---|
| GPIO10 | nINT (Active Low) | Interrupt to the PXA processor notifying a button pressed event (i.e. possible user triggered system shutdown). |
| GPIO16 | nKILL (Active Low) | GPIO used to trigger a software shutdown of the system. GPIO16 must be set to high at startup to prevent an automatic shutdown. |



3.2.2 DC-Input X6

Connector for 5V DC.
 Manufacturer: KYCON
 Manufacturer reference: KLDX-SMT-0201L-B
 Recommended plug dimensions:
 Outer diameter: 3.5mm (0V)
 Inner diameter: 1.3mm (+5V)

Please use an external power supply that meets the following specifications:
 Input voltage: 5V DC (10% tolerance)
 Input current: min 1.5A (Limestone has an on-board 4A fast fuse)
 Connector: Jack with 1.3mm inner diameter (polarity: inner pin is hot on X6)

3.2.3 USB Micro A/B (Host/Device) X58

Standard USB Micro AB connector for USB Host and USB Device.

3.2.4 Head-Set Jag X61

Standard 2.5mm Audio connector for Headphone and Microphone.
 Signal assignment from ring to tip:
 GND, MIC1, HPR, HPL

3.2.5 Battery Pack X12

Connector for Li-ion or Li-polymer single cell battery.

| Pin# | Signal Name |
|------|-------------|
| 1 | PACK+ |
| 2 | PACK+ |
| 3 | TS |
| 4 | GND |
| 5 | CELL- |
| 6 | CELL- |

Manufacturer: Molex
 Manufacturer reference: 90325-0006
 Corresponding mating connector: 90327-0306

The Limestone Baseboard can handle almost any single-cell Li-Ion or Li-Pol rechargeable battery (nominal cell voltage 3.6/3.7V). The maximum charging current is set to 1.45 amps. Toradex recommends using a Lithium Ion Polymer battery manufactured by Kokam, reference SLPB526495 (3.3 Ah). This battery with a dedicated PCM circuit, cable and mating connector can be directly ordered through Toradex. Visit our website <http://www.toradex.com> for more information on prices and availability.

3.2.6 MMC/SD Card Slot X11

The MMC/SD card slot on the Limestone PDA Baseboard accepts the standard SD sized cards. Mini-SD and Micro-SD cards can also be used if they are used with the correct size adapter.



3.2.7 Extension Connector (X2)

Manufacturer: Hirose (<http://www.hirose-connectors.com>)

Manufacturer reference: FX10A-140S/14-SV(71)

Toradex recommends using one of the following “Headers with ground plate” and with “guideposts”:

FX10A-140P/14-SV(71) – 4 mm stacking height

FX10A-140P/14-SV1(71) – 5 mm stacking height

Remarks:

- I. The connector has 140 individual signal pins split in groups by 14 ring connections (all assigned to GND). The rated current is 0.3 A per pin. For further details, please refer to the manufacturer’s datasheet. The following pin assignment table only includes individual signal pins.
- II. “GPIOx/GPIOy” denotes that “GPIOx” and “GPIOy” are multiplexed (see §3.3.11).
- III. Alternate functions of GPIOs are described in the volume 1 of the PXA3xx datasheet available at http://www.marvell.com/products/cellular/application/PXA3xx_series.jsp

| Pin# | Signal Name | Note |
|------|------------------|------|
| 1 | OUT3_AC | 2 |
| 3 | HPR_AC | 2 |
| 5 | HPL_AC | 2 |
| 7 | SPKL | 2 |
| 9 | SPKR | 2 |
| 11 | PCM_CLK | 2 |
| 13 | PCM_SYNC | 2 |
| 15 | PCM_IN | 2 |
| 17 | PCM_OUT | 2 |
| 19 | +3.3V | |
| 21 | GPIO97 | 1 |
| 23 | GPIO98 | 1 |
| 25 | GPIO99/GPIO113 | 1 |
| 27 | GPIO101 | 1 |
| 29 | GPIO103 | 1 |
| 31 | DF_ADDR[2] | 1 |
| 33 | DF_ADDR[3] | 1 |
| 35 | DF_IO[0] | 1 |
| 37 | DF_IO[1] | 1 |
| 39 | DF_IO[3] | 1 |
| 41 | DF_IO[5] | 1 |
| 43 | DF_IO[7] | 1 |
| 45 | DF_IO[9] | 1 |
| 47 | DF_IO[11] | 1 |
| 49 | DF_IO[13] | 1 |
| 51 | DF_IO[15] | 1 |
| 53 | GPIO17_2 (LBIAS) | 1 |
| 55 | GPIO83 | 1 |
| 57 | GPIO84 | 1 |

| Pin# | Signal Name | Note |
|------|---------------------|------|
| 2 | EAR_MT- | 2 |
| 4 | EAR_MT+ | 2 |
| 6 | MIC_MT+ | 2 |
| 8 | MIC2B | 2 |
| 10 | MIC1_AC | 2 |
| 12 | TSPX | 2 |
| 14 | TSPY | 2 |
| 16 | TSMX | 2 |
| 18 | TSMY | 2 |
| 20 | RESET_OUT# | |
| 22 | RESET_EXT# | 1 |
| 24 | SYS_EN | 1 |
| 26 | GPIO3/GPIO100 | 1 |
| 28 | GPIO102/GPIO117 | 1 |
| 30 | GPIO88/GPIO104 | 1 |
| 32 | DF_ADV1_ALE# | 1 |
| 34 | ND_CLE | 1 |
| 36 | XCVREN# | 1 |
| 38 | LUA# | 1 |
| 40 | LLA# | 1 |
| 42 | DF_IO[2] | 1 |
| 44 | DF_IO[4] | 1 |
| 46 | DF_IO[6] | 1 |
| 48 | DF_IO[8] | 1 |
| 50 | DF_IO[10] | 1 |
| 52 | DF_IO[12] | 1 |
| 54 | DF_IO[14] | 1 |
| 56 | GPIO4/GPIO109 | 1 |
| 58 | GPIO110/EXT_WAKEUP0 | 1, 3 |



| Pin# | Signal Name | Note |
|------|------------------------|------|
| 59 | GPIO85 | 1 |
| 61 | GPIO86 | 1 |
| 63 | GPIO14_2 (VSYNC) | 1 |
| 65 | GPIO15_2 (HSYNC) | 1 |
| 67 | GPIO7_2 (LDD1) | 1 |
| 69 | GPIO9_2 (LDD3) | 1 |
| 71 | GPIO11_2 (LDD5) | 1 |
| 73 | GPIO13_2 (LDD7) | 1 |
| 75 | GPIO64 (LDD9) | 1 |
| 77 | GPIO66 (LDD11) | 1 |
| 79 | GPIO68 (LDD13) | 1 |
| 81 | GPIO70 (LDD15) | 1 |
| 83 | GPIO72 (LDD17) | 1 |
| 85 | GPIO115 | 1 |
| 87 | GPIO118 | 1 |
| 89 | GPIO0_2/GPIO12/GPIO120 | 1 |
| 91 | GPIO122/PXCVREN# | 1 |
| 93 | GPIO126 | 1 |
| 95 | GPIO49 | 1 |
| 97 | GPIO50/PREG# | 1 |
| 99 | GPIO6/GPIO51 | 1 |
| 101 | GPIO5/GPIO52 | 1 |
| 103 | GPIO30/GPIO53 | 1 |
| 105 | GPIO31/GPIO54 | 1 |
| 107 | GPIO55 | 1 |
| 109 | GPIO14/GPIO56 | 1 |
| 111 | GPIO57/GPIO125 | 1 |
| 113 | GPIO58/GPIO124 | 1 |
| 115 | GPIO59/GPIO77 | 1 |
| 117 | GPIO11/GPIO60/PCE2# | 1 |
| 119 | GPIO61/PCE1# | 1 |
| 121 | GPIO62/GPIO81 | 1 |
| 123 | SUPPLY+ | |
| 125 | SUPPLY+ | |
| 127 | SUPPLY+ | |
| 129 | DC_IN_SUPPLY+ | |
| 131 | BATT+ | |
| 133 | BATT + | |
| 135 | BATT + | |
| 137 | BATT + | |
| 139 | BATT + | |

| Pin# | Signal Name | Note |
|------|--------------------|------|
| 60 | GPIO111 | 1 |
| 62 | GPIO112 | 1 |
| 64 | +3.3V | |
| 66 | GPIO16_2 (DOTCLK) | 1 |
| 68 | GPIO6_2 (LDD0) | 1 |
| 70 | GPIO8_2 (LDD2) | 1 |
| 72 | GPIO10_2 (LDD4) | 1 |
| 74 | GPIO12_2 (LDD6) | 1 |
| 76 | GPIO63 (LDD8) | 1 |
| 78 | GPIO65 (LDD10) | 1 |
| 80 | GPIO67 (LDD12) | 1 |
| 82 | GPIO69 (LDD14) | 1 |
| 84 | GPIO71 (LDD16) | 1 |
| 86 | GPIO114 | 1 |
| 88 | GPIO116 | 1 |
| 90 | GPIO119 | 1 |
| 92 | GPIO121 | 1 |
| 94 | GPIO123 | 1 |
| 96 | GPIO13/GPIO127 | 1 |
| 98 | +3.3V | |
| 100 | GPIO24 | 1 |
| 102 | GPIO25 | 1 |
| 104 | GPIO26 | 1 |
| 106 | GPIO27/RDnWE | 1 |
| 108 | GPIO28 | 1 |
| 110 | GPIO29/EXT_WAKEUP1 | 1, 3 |
| 112 | GPIO48 | 1 |
| 114 | SCL | 1 |
| 116 | SDA | 1 |
| 118 | USBH1_P | |
| 120 | USBH1_N | |
| 122 | USB5V | |
| 124 | USB5V | |
| 126 | SUPPLY+ | |
| 128 | SUPPLY+ | |
| 130 | PUSH_IN | |
| 132 | BATT + | |
| 134 | BATT + | |
| 136 | BATT + | |
| 138 | BATT + | |
| 140 | BATT + | |



3.2.8 Microphone X1

Connector for external microphone

Manufacturer: Molex

Manufacturer reference: 53048-0210

Corresponding mating connector: 51021-0200

| Pin# | Signal Name | Note |
|------|-------------|------|
| 1 | MICCM | 2 |
| 2 | MIC2A | 2 |

3.2.9 Speaker X4

Connector for external loudspeaker

Manufacturer: Molex

Manufacturer reference: 53048-0210

Corresponding mating connector: 51021-0200

| Pin# | Signal Name | Note |
|------|-------------|------|
| 1 | SPKR | 2 |
| 2 | SPKL | 2 |

3.2.10 JTAG Connector (_X2)

Manufacturer: Molex

Manufacturer reference: 52746-0870 (FFC 8 pins, 0.5mm pitch, bottom contact)

| Pin# | Signal Name | Note |
|------|-------------|------|
| 1 | +3V3 | |
| 2 | GND | |
| 3 | TMS | 1 |
| 4 | nTRST | 1 |
| 5 | TCK | 1 |
| 6 | TDO | 1 |
| 7 | TDI | 1 |
| 8 | RESET_EXT# | |

Notes:

1. For the electrical specification please refer to PXA320 Processor Electrical, Mechanical and Thermal Specification Datasheet
2. For the electrical specification please refer to Audio and Touch Screen Controller WM9713G datasheet
3. See chapter 3.3.12EXT_WAKEUPx for more details.



3.3 Signal Description

3.3.1 PACK+

This is the positive terminal of the Li-Ion cell. The voltage can vary between 3.3V and 4.3V, depending on the charge status of the battery.

3.3.2 DC_IN_SUPPLY+

DC_IN_SUPPLY+ is either the DC-IN voltage from an external power supply or the Li-Ion cell's positive terminal if no external supply is connected. The voltage on this rail can vary between 3.3V and 5.5V.

On the Limestone PDA Baseboard, only fuel gauge and RTC are powered by this supply, to keep the discharge of the battery to a minimum during storage of the device.

3.3.3 CELL-

This is the negative terminal of the Li-Ion cell.

The level on this net is approximately 0V, only a very small shunt resistor separates CELL- from GND.

3.3.4 BATT+

This is the positive terminal of the Li-Ion cell. The voltage can vary between 3.3V and 4.3V, depending on the charge status of the battery.

In contrast to PACK+ (see above), BATT+ can be interrupted using the integrated ON/OFF switch.

3.3.5 SUPPLY+

SUPPLY+ is either the DC-IN voltage from an external power supply or the Li-Ion cell's positive terminal if no external supply is connected. The voltage on this rail can vary between 3.3V and 5.5V.

SUPPLY+ can be interrupted using the integrated ON/OFF switch.

3.3.6 TS

Terminal for an optional thermal sensor inside the Li-Ion cell pack. This is currently not supported. Please leave this pin open.

3.3.7 +3.3V

Regulated 3.3V DC voltage supply e.g. for additional logic devices on the extension board

3.3.8 USB5V

Regulated 5V DC voltage supply for USB host; switchable by software

3.3.9 GND

Ground reference for all digital signals.

3.3.10 PUSH_IN

Additional connection to the ON/OFF Push Button Controller on the Limestone PDA Baseboard. This signal can be used to add a dedicated ON/OFF switching on the extension board. PUSH_IN is active low. The input of the button controller has an internal pull-up to DC_IN_Supply+.

3.3.11 GPIOx

The GPIO pins are direct outputs of the PXA320 processor. For details about functionality and programming of these pins please see the PXA320 datasheets.

Some of the board-to-board connector pins have more than one PXA320 GPIO assigned. If you would like to use one of them, you should tristate the other one (set to GPIO input). For example you can use an alternate function of the GPIO6. Then you have to set the GPIO51 to GPIO input.



GPIO56 and GPIO[62:59] do not have an alternate function GPIO (neither altFn0 nor another altFn is GPIO). You could use the second GPIO assigned to some of these pins instead. But you cannot use GPIO60 and GPIO61 as GPIO since there is no other GPIO assigned to these pins.

The GPIO0 to GPIO17 have a second instance on the PXA320. (GPIO0_2 to GPIO17_2). They are assigned to different balls on the PXA320. You can use one of them as GPIO and the other one should have a different alternate function than GPIO. The GPIO registers are the same for both (e.g. GPIO0 and GPIO_2 share the same bit in the GPIO level register GPLR0[0]). Be careful when using both as GPIO. When choosing GPIO input, then the value in the GPIO level register is GPIOx OR GPIOx_2. When choosing output, both GPIO pins will provide the level from the level register.

3.3.12 EXT_WAKEUPx

The EXT_WAKEUPx signals pin X2-58 and X2-110 are the main wakeup sources of the PXA320. However the PXA320 is able to wake-up from suspend (Sleep) with many other GPIO pins. Check Toradex' website for more information. Tristate (set to input) the corresponding GPIO's when using this pins as EXT_WAKEUP. For more information about EXT_WAKEUP pins see the PXA320 developer's manual.

3.3.13 USBH1_x

These are differential USB Host 1.1 positive (P) and negative (N) data signals.

3.3.14 Audio and Touch Signals

The audio and touch signals are mainly input or outputs of Wolfson's WM9713G audio codec. Please see the WM9713G datasheet for more information about the following signals (GPIO1 to 5 are related to the WM9113G and not the PXA320!).

| Signal Name | Pin on WM9713 |
|----------------|---------------|
| OUT3_AC | 37 (OUT3) |
| HPR_AC (HPR) | 41 (HPR) |
| HPL_AC (HPL) | 39 (HPL) |
| SPKR | 36 (SPKR) |
| SPKL | 35 (SPKL) |
| EAR_MT- | 19 (PCBEEP) |
| EAR_MT+ | 20 (MONOIN) |
| MIC_MT+ | 31 (MONO) |
| MIC1_AC (MIC1) | 21 (MIC1) |
| MIC2B | 30 (MIC2B) |
| PCM_IN | 47 (GPIO4) |
| PCM_OUT | 48 (GPIO5) |
| PCM_SYNC | 46 (GPIO3) |
| PCM_CLK | 44 (GPIO1) |
| TSPX | 14 (X+/BR) |
| TSMX | 16 (X-/TL) |
| TSPY | 15 (Y+/TR) |
| TSMY | 17 (Y-/BL) |

3.3.15 RESET_EXT#

This is the global reset pin. It is pulled-up to 3.3V. Pull this signal to 0V to generate a global reset.

3.3.16 RESET_OUT#

Reset signal coming out of the PXA320.



3.3.17 SYS_EN

System enable signal generate by the PXA320. Use this signal as an enable for additional power supplies or interfaces to ensure correct operation.

3.3.18 I2C Serial Interface

The two lines of the I2C serial port of the PXA320 are available on the extension connector.

| Signal Name | Function |
|-------------|--------------|
| SCL | Serial Clock |
| SDA | Serial Data |

3.3.19 PXA320 Processor Bus

The processor bus of the PXA320 processor is available on the extension connector to enable the integration of peripherals on the extension board. Please refer to the PXA3xx Processor datasheet for further information on how to connect these signals.

| Signal Name | Function |
|---------------------------------------|-------------------------------------|
| DF_ADDR[x] | Bus Address Line |
| DF_IO[x] | Bus Bidirectional Data Line |
| DF_ADV1_ALE# | Address Latch Enable / Write Enable |
| ND_CLE | Command Latch Enable |
| XCVREN# | External Transceiver Enable |
| LUA# | Latch Upper Address |
| LLA# | Latch Lower Address |
| GPIO3 (nCS2 as Alternate Function) | Chip Select |
| GPIO4 (nCS3 as Alternate Function) | Chip Select |



4. Technical Specifications

4.1 Electrical Characteristics

| Symbol | Description | Min | Typ | Max | Unit |
|------------|--|------|-----|------|------|
| VDCIN | DC Power supply voltage | 4.3 | 5.3 | 5.5 | V |
| VBATT | Battery supply voltage | 3.4 | 3.7 | 4.3 | V |
| IDD_806A | Operating at 806 MHz, Display off, Idle | | 220 | | mA |
| IDD_806B | Operating at 806 MHz, Display on, Idle | | 244 | | mA |
| IDD_806C | Operating at 806 MHz, Display on, 100% CPU | | 428 | 678 | mA |
| IDD_SUSP | In Suspend-Mode | | 2.1 | | mA |
| IDD_CHARGE | Battery Charging Current | 0 | | 1.45 | A |
| VIH | Digital input high voltage | 2.7 | 3.3 | 3.6 | V |
| VIL | Digital input low voltage | -0.3 | | 0.6 | V |

4.2 Mechanical Characteristics

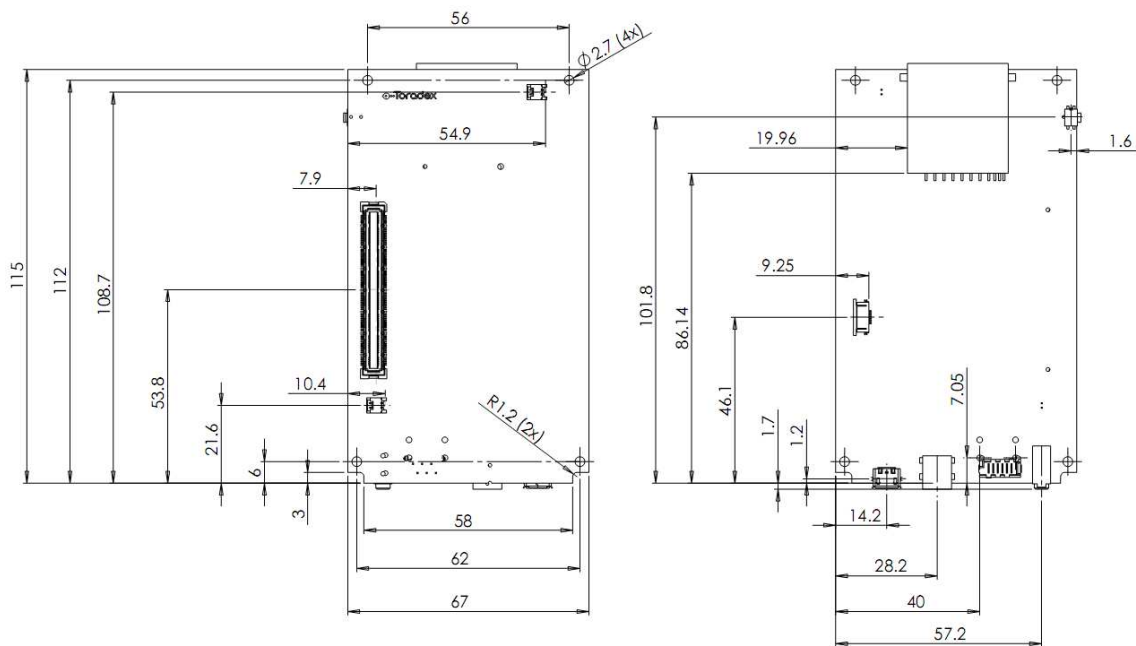

Fig. 5: Mechanical dimensions in [mm].

The complete CAD data of the Limestone PDA Baseboard is available in many different formats. Please visit <http://www.3dcontentcentral.com/parts/supplier/Toradex.aspx> to download the latest version.

4.3 Temperature Range

| Module | Description | Min | Typ | Max | Unit |
|-------------------------|-----------------------------|-----|-----|-----|------|
| Limestone PDA Baseboard | Operating temperature range | 0 | | 70 | °C |

4.4 RoHS Compliance

All Limestone components modules comply with the European Union's Directive 2002/95/EC: "Restrictions of Hazardous Substances".



5. Customization

The Limestone PDA Kit consists of two separate PCBs. All on-board features are implemented on the Limestone PDA Baseboard. A rich board-to-board extension interface offers plenty of options to add an extension board inside the PDA with customer-specific electronics, such as WLAN, Bluetooth, GSM, GPRS, GPS, Camera, RFID/Barcode Scanners or even specific sensors to measure acceleration or orientation. All operating system images contain drivers for the most common interfaces and can be easily customized by registry settings to adapt to the specific hardware.

Dedicated front and back covers can be developed and manufactured to meet customer specific requirements, from a slick to a ruggedized design, for in- or outdoor usage.

Please contact Toradex at limestone@toradex.com for more information about the customization of the Limestone PDA Kit.



Disclaimer:

Copyright © Toradex AG. All rights reserved. All data is for information purposes only and not guaranteed for legal purposes. Information has been carefully checked and is believed to be accurate; however, no responsibility is assumed for inaccuracies.

Brand and product names are trademarks or registered trademarks of their respective owners. Specifications are subject to change without notice.