

35 MHz Analog Oscilloscope HM303-6

Service manual

English

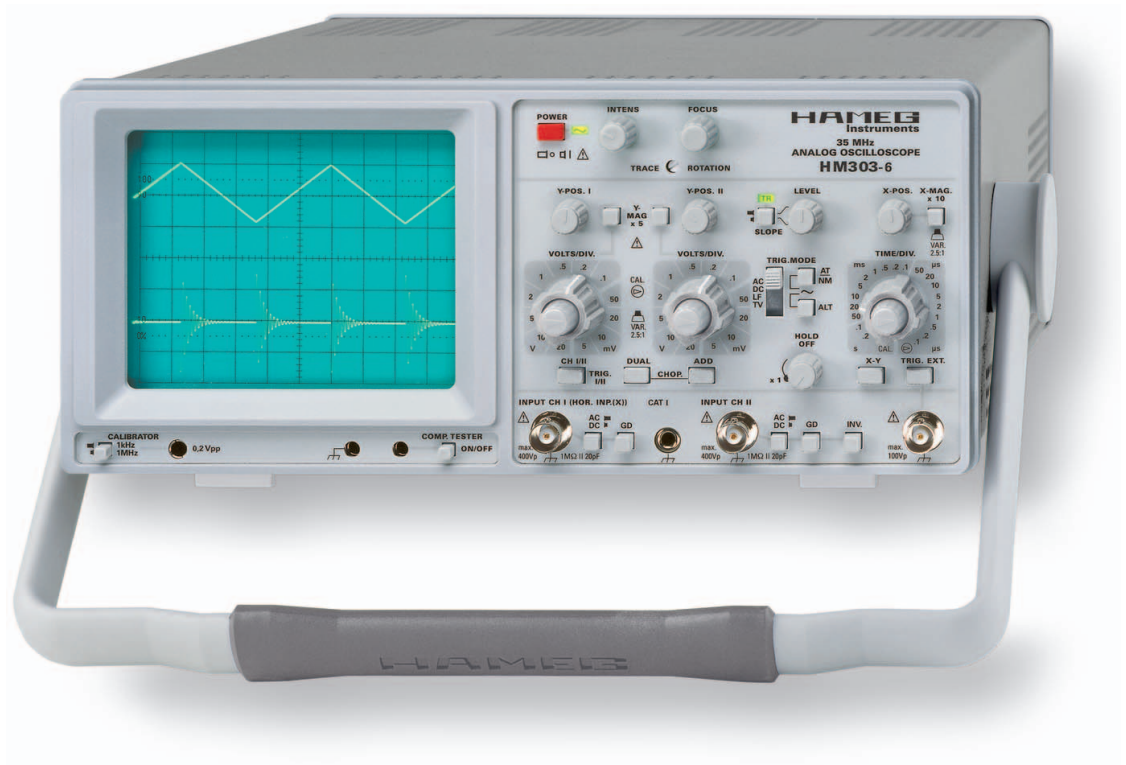



Hersteller
Manufacturer
Fabricant

HAMEG Instruments GmbH
Industriestraße 6
D-63533 Mainhausen

KONFORMITÄTSERKLÄRUNG
DECLARATION OF CONFORMITY
DECLARATION DE CONFORMITE

HAMEG[®]
Instruments

Die HAMEG Instruments GmbH bescheinigt die Konformität für das Produkt
The HAMEG Instruments GmbH herewith declares conformity of the product
HAMEG Instruments GmbH déclare la conformité du produit

Bezeichnung / Product name / Designation:

Oszilloskop
Oscilloscope
Oscilloscope

Typ / Type / Type:

HM303-6

mit / with / avec:

-

Optionen / Options / Options:

-

mit den folgenden Bestimmungen / with applicable regulations / avec les directives suivantes

EMV Richtlinie 89/336/EWG ergänzt durch 91/263/EWG, 92/31/EWG
EMC Directive 89/336/EEC amended by 91/263/EWG, 92/31/EEC
Directive EMC 89/336/CEE amendée par 91/263/EWG, 92/31/CEE

Niederspannungsrichtlinie 73/23/EWG ergänzt durch 93/68/EWG
Low-Voltage Equipment Directive 73/23/EEC amended by 93/68/EEC
Directive des équipements basse tension 73/23/CEE amendée par 93/68/CEE

Angewendete harmonisierte Normen / Harmonized standards applied / Normes harmonisées utilisées:

Sicherheit / Safety / Sécurité: EN 61010-1:2001 (IEC 61010-1:2001)
Überspannungskategorie / Overvoltage category / Catégorie de surtension: II
Verschmutzungsgrad / Degree of pollution / Degré de pollution: 2

Elektromagnetische Verträglichkeit / Electromagnetic compatibility /
Compatibilité électromagnétique

EN 61326-1/A1 Störaussendung / Radiation / Emission:
Tabelle / table / tableau 4; Klasse / Class / Classe B.

Störfestigkeit / Immunity / Imunité: Tabelle / table / tableau A1.

EN 61000-3-2/A14 Oberschwingungsströme / Harmonic current emissions /
Émissions de courant harmonique:
Klasse / Class / Classe D.

EN 61000-3-3 Spannungsschwankungen u. Flicker / Voltage fluctuations and flicker /
Fluctuations de tension et du flicker.

Datum /Date /Date
01. 04. 2007

Unterschrift / Signature / Signatur

Holger Asmussen
Manager

General information regarding the CE marking

HAMEG instruments fulfill the regulations of the EMC directive. The conformity test made by HAMEG is based on the actual generic- and product standards. In cases where different limit values are applicable, HAMEG applies the severer standard. For emission the limits for residential, commercial and light industry are applied. Regarding the immunity (susceptibility) the limits for industrial environment have been used.

The measuring- and data lines of the instrument have much influence on emission and immunity and therefore on meeting the acceptance limits. For different applications the lines and/or cables used may be different. For measurement operation the following hints and conditions regarding emission and immunity should be observed:

1. Data cables

For the connection between instrument interfaces and external devices, (computer, printer etc.) sufficiently screened cables must be used. Without a special instruction in the manual for a reduced cable length, the maximum cable length of a dataline must be less than 3 meters and not be used outside buildings. If an interface has several connectors only one connector must have a connection to a cable.

Basically interconnections must have a double screening. For IEEE-bus purposes the double screened cables HZ73 and HZ72L from HAMEG are suitable.

2. Signal cables

Basically test leads for signal interconnection between test point and instrument should be as short as possible. Without instruction in the manual for a shorter length, signal lines must be less than 3 meters and not be used outside buildings.

Signal lines must be screened (coaxial cable - RG58/U). A proper ground connection is required. In combination with signal generators double screened cables (RG223/U, RG214/U) must be used.

3. Influence on measuring instruments

Under the presence of strong high frequency electric or magnetic fields, even with careful setup of the measuring equipment, influence of such signals is unavoidable.

This will not cause damage or put the instrument out of operation. Small deviations of the measuring value (reading) exceeding the instruments specifications may result from such conditions in individual cases.

4. RF immunity of oscilloscopes.

4.1 Electromagnetic RF field

The influence of electric and magnetic RF fields may become visible (e.g. RF superimposed), if the field intensity is high. In most cases the coupling into the oscilloscope takes place via the device under test, mains/line supply, test leads, control cables and/or radiation. The device under test as well as the oscilloscope may be effected by such fields.

Although the interior of the oscilloscope is screened by the cabinet, direct radiation can occur via the CRT gap. As the bandwidth of each amplifier stage is higher than the total -3dB bandwidth of the oscilloscope, the influence of RF fields of even higher frequencies may be noticeable.

4.2 Electrical fast transients / electrostatic discharge

Electrical fast transient signals (burst) may be coupled into the oscilloscope directly via the mains/line supply, or indirectly via test leads and/or control cables. Due to the high trigger and input sensitivity of the oscilloscopes, such normally high signals may effect the trigger unit and/or may become visible on the CRT, which is unavoidable. These effects can also be caused by direct or indirect electrostatic discharge.

HAMEG Instruments GmbH

Analog Oscilloscope HM303-6	4
Specifications	5
Front Panel Elements – Brief Description	6
Short Description of HM303-6 Boards	9
1 YP Board	9
2 XY Board	9
3 TB Board	10
4 CR Board	10
5 CC Board	10
6 FC Board	11
7 PS Board	11
PCB Interconnections	12
Board Replacement	14
1 PS Board	14
2 FC Board	15
3 CC Board	17
4 YP Board	17
5 XY Board	18
6 TB Board	19
7 CR Board	20
HM303-6 Troubleshooting	21
Security advice!	21
1 Opening the Oscilloscope	21
2 Preliminary Tests	22
3 Error Diagnostics!	25
Performance Check HM303-6	31
A Test Instruments required	31
B Basic Settings	31
C Checks	31
Spare-Part List HM303-6	38
Adjustment Procedure HM303-6	39

35 MHz Analog Oscilloscope HM303-6

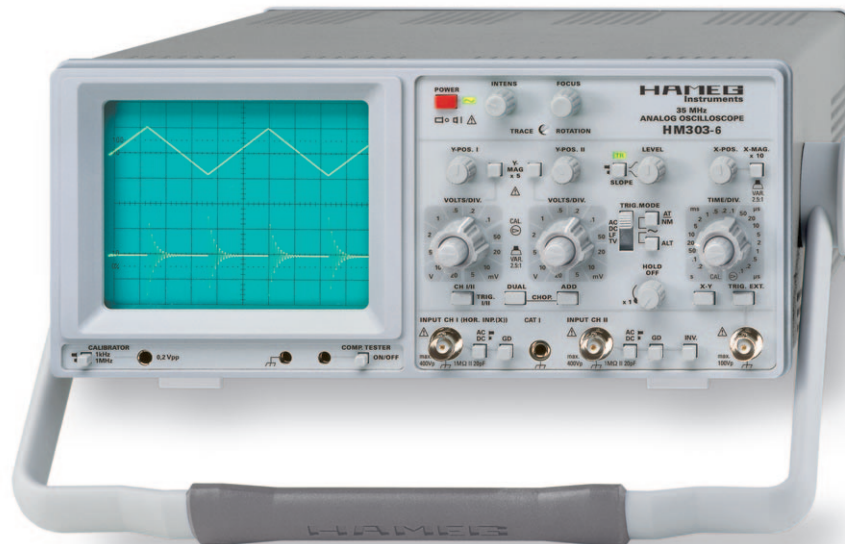

2 Channels with deflection coefficients of 1 mV/cm – 20 V/cm

Time Base: 0.2 s/cm – 100 ns/cm,
with X Magnification to 10 ns/cm

Low Noise Measuring Amplifiers with high pulse fidelity
and minimum overshoot

Triggering from 0 to 50 MHz from 5 mm signal level
(up to 100 MHz from 8 mm)

Up to 500,000 signal displays per second
in optimum analog quality

Yt, XY and component-test modes

No signal distortion
resulting from overshoot

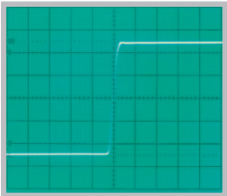

Line triggered composite
video signal

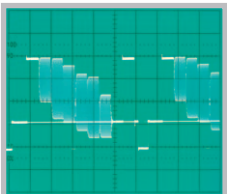

Full screen display of
35 MHz sine wave signal

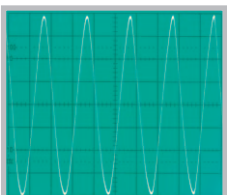

35 MHz Analog Oscilloscope HM303-6

Valid at 23 °C after a 30 minute warm-up period

Vertical Deflection

Operating Modes:	Channel I or II only Channels I and II (alternate or chopped) Sum or Difference of CH I and CH II
Invert:	CH II
XY Mode:	via CH I (X) and CH II (Y)
Bandwidth:	2 x 0 to 35 MHz (-3 dB)
Rise Time:	< 10 ns
Overshoot:	max. 1%
Deflection Coefficients:	1-2-5 Sequence
1 mV/div. - 2 mV/div.:	± 5% (Bandwidth 0 - 10 MHz (-3 dB))
5 mV/div. - 20 V/div.:	± 3% (Bandwidth 0 - 35 MHz (-3 dB))
Variable (uncalibrated):	> 2.5 : 1 to > 50 V/div.
Input Impedance:	1 MΩ 20 pF
Input Coupling:	DC, AC, GND (ground)
Max. Input Voltage:	400 V (DC + peak AC)

Triggering

Automatic (Peak to Peak):	20 Hz - 50 MHz (≥ 5 mm) 50 MHz - 100 MHz (≥ 8 mm)
Normal with Level Control:	0 - 50 MHz (≥ 5 mm) 50 MHz - 100 MHz (≥ 8 mm)
Trigger Indicator:	LED
Slope:	positive or negative
Sources:	Channel I or II, CH I / CH II alternate (≥ 8 mm), Line and External
Coupling:	AC: 10 Hz - 100 MHz DC: 0 - 100 MHz LF: 0 - 1.5 kHz
Trigger Indicator:	LED
External Trigger Signal:	≥ 0.3 V _{pp} (30 Hz - 50 MHz)
Active TV sync. separator:	pos. and neg.

Horizontal Deflection

Time Base:	0.2 s/div. - 0.1 μs/div. (1-2-5 Sequence)
Accuracy:	± 3%
Variabel (uncalibrated):	> 2.5:1 to > 0.5 s/div.
X Magnification x 10:	up to 10 ns/div.
Accuracy:	± 5%
Hold-Off Time:	variable to approx. 10 : 1
XY	
Bandwidth X Amplifier:	0 - 2.5 MHz (-3 dB)
XY Phase shift < 3°:	< 120 kHz

Component Tester

Test Voltage:	approx. 7 V _{rms} (open circuit)
Test Current:	max. 7 mA _{rms} (short-circuit)
Test Frequency:	approx. 50 Hz
Test Connection:	2 banana jacks 4 mm Ø

One test circuit lead is grounded via protective earth (PE)

Miscellaneous

CRT:	D14-363GY, 8 x 10 cm with internal graticule
Acceleration Voltage:	approx. 2 kV
Trace Rotation:	adjustable on front panel
Calibrator Signal (Square Wave):	0.2V ± 1%, ≈ 1 kHz/1 MHz (tr < 4 ns)
Power Supply (Mains):	105 - 253 V, 50/60 Hz ± 10%, CAT II
Power Consumption:	approx. 36 Watt at 230 V/50 Hz
Ambient temperature:	0 °C...+ 40 °C
Safety class:	Safety class I (EN61010-1)
Weight:	approx. 5.4 kg
Dimensions (W x H x D):	285 x 125 x 380 mm

Accessories supplied: Line Cord, operator's manual, 2 Probes 1:1 / 10:1 (HZ154)

www.hameg.com

Front Panel Elements – Brief Description

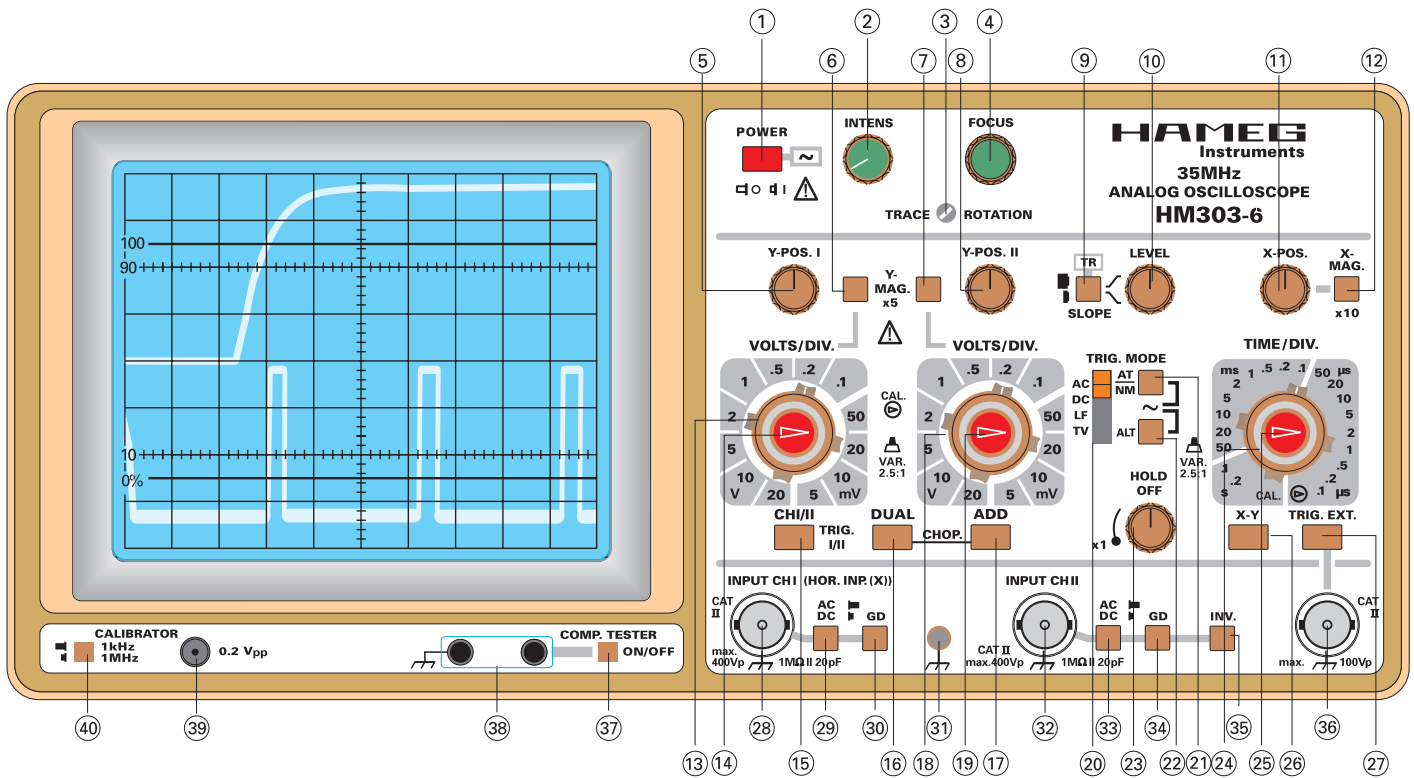

Element	Function
① POWER (pushbutton + LED)	Turns scope on and off. LED indicates operating condition.
② INTENS (knob)	Intensity control for trace brightness
③ TRACE ROTATION (potentiometer; adjustment with screwdriver)	To align trace with horizontal graticule line. Compensates influence of earth's magnetic field.
④ FOCUS (knob)	Focus control for trace sharpness.
⑤ Y-POS. I (knob)	Controls vertical position of channel I display. Inoperative in X-Y mode.
⑥ Y MAG. x5 (pushbutton switch)	When depressed, increasing of Y-sensitivity CH I 5 fold (max. 1mV/div.)
⑦ Y MAG. x5 (pushbutton switch)	When depressed, increasing of Y-sensitivity CH II 5 fold (max. 1mV/div.)
⑧ Y-POS. II (knob)	Controls vertical position of channel II display.
⑨ SLOPE $\nearrow \searrow$	Selects the slope of the trigger signal.

Element	Function
⑩ SLOPE $\nearrow \searrow$ (pushbutton switch)	\nearrow = rising edge; \searrow = falling edge.
TR (LED)	LED lights, if sweep is triggered.
⑪ LEVEL (knob)	Adjustment of trigger level.
⑫ X-POS. (knob)	Controls horizontal position of trace.
⑬ X-MAG. x10 (pushbutton switch)	10:1 expansion in the X direction. Max. resolution 10ns/div. (inoperative in XY-mode).
⑭ VOLTS/DIV. (12 position rotary switch)	Channel I input attenuator. Selects Y input sensitivity in mV/div. or V/div. in 1-2-5 sequence.
⑮ VAR. GAIN (knob)	Fine adjustment of Y amplitude CH I. Increases attenuation factor min. by 2.5 (left hand stop). For amplitude measurement must be in CAL. position (right hand stop).
⑯ CH I/II-TRIG. I/II (pushbutton switch)	No button depressed: CH I only and triggering from channel I. When depressed, channel II only and triggering from channel II. (Trigger selection in DUAL mode).

<i>Element</i>	<i>Function</i>	<i>Element</i>	<i>Function</i>
⑩ DUAL (pushbutton switch)	Button released: one channel only. Button depressed: channel I and channel II in alternating mode.	⑩ XY (pushbutton switch)	Selects X-Y operation, stops sweep. X signal via CH I. Attention! Phosphor burn-in without signal.
	CHOP. DUAL and ADD buttons depressed: CH I and CH II in chopped mode.	⑪ TRIG. EXT. (pushbutton switch)	Button released = internal trig. Button depressed = external triggering, trigger signal via TRIG. EXT. BNC socket.
⑪ ADD (pushbutton switch)	ADD depressed only: algebr. addition. In combination with INV.: difference.	⑫ INPUT CH I (BNC socket)	Channel I signal input and input for horizontal deflection in X-Y mode. Input impedance 1MΩ 20pF.
⑫ VOLTS/DIV. (12 position rotary switch)	Channel II input attenuator. Selects Y input sensitivity in mV/div. or V/div. in 1-2-5 sequence.	⑬ AC-DC (pushbutton switch)	Selects input coupling of CH I vertical amplifier. DC = direct coupling AC = coupling via capacitor.
⑬ VAR. GAIN (knob)	Fine adjustment of Y amplitude CH II. Increases attenuation factor min. by 2.5 (left hand stop). For amplitude measurement must be in CAL. position (right hand stop).	⑭ GD (pushbutton switch)	GD = signal disconnected from input, Y amplifier grounded.
⑭ TRIG. MODE (switch) AC-DC-LF-TV	Trigger selector: AC: 10Hz-100MHz. DC: DC-100MHz. LF: DC-1.5kHz. TV: Triggering for frame and line.	⑮ (4mm socket)	Connector for reference potential (galvanically connected to earth).
⑮ AT/NM (pushbutton switch)	Button released = autom. trig. trace visible without input signal. Button depressed = normal trig. with LEVEL adjustment.	⑯ INPUT CH II (BNC socket)	CH II signal input. Input impedance 1MΩ 20pF.
	AT/NM and ALT pushbuttons depressed: Internal line triggering in combi- nation with normal triggering.	⑰ AC-DC (pushbutton switch)	Selects input coupling of the CH II vertical amplifier. Specs see (29).
⑰ ALT (pushbutton switch)	Triggering alternates between CH I and CH II in alternating DUAL Channel mode only.	⑱ GD (pushbutton switch)	GD = signal disconnected from input, Y amplifier grounded.
⑱ HOLD OFF (knob)	Controls holdoff-time between sweeps. Normal position = full ccw.	⑲ INV. (pushbutton switch)	Inversion of CH II display. In combination with ADD button = difference CH I, CH II.
⑲ TIME/DIV. (rotary switch)	Selects time coefficients (speeds) of time base, from 0.2s/div. to 0.1μs/div.	⑳ TRIG. EXT. (BNC socket)	Input for external trigger signal. (Pushbutton TRIG. EXT. depressed.)
⑲ Variable time base control (center knob)	Variable adjustment of time base. Decreases time deflection speed at least 2.5 fold. For time measurements turn to right hand stop.	㉑ COMP. TESTER (pushbutton switch)	Switch to convert oscilloscope to component tester mode. Release X-MAG. X10 pushbutton.
		㉒ COMP. TESTER (4mm sockets)	Connectors for test leads of the Component tester.
		㉓ 0.2V_{pp} (test socket)	Calibrator square wave output 0,2V _{pp} .
		㉔ CALIBRATOR 1kHz/1MHz (pushbutton switch)	Selects calibrator frequency. Button released: approx. 1kHz, Button depressed: approx. 1MHz.

Blockdiagram

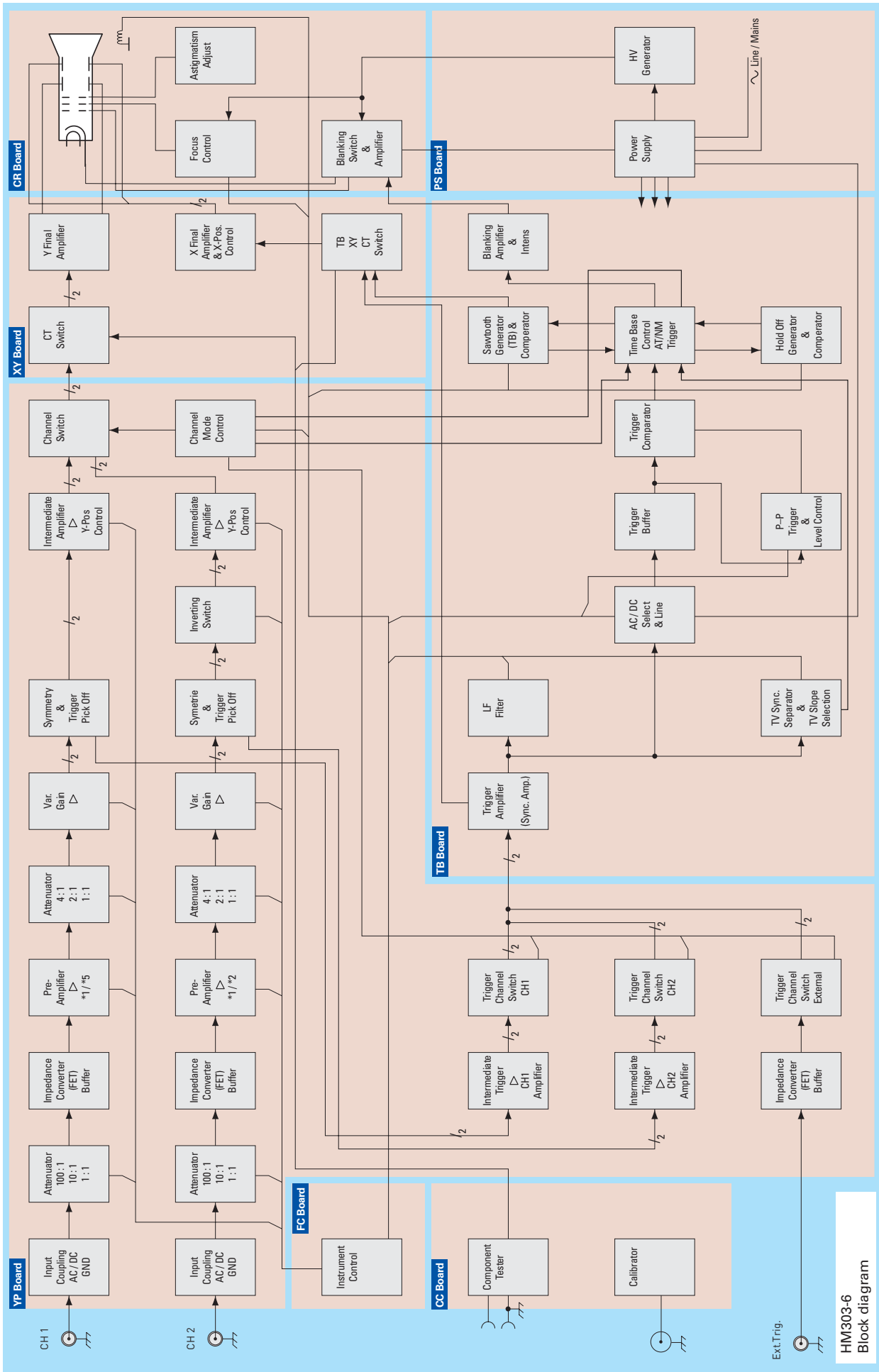

HM303-6
Block diagram

Short Description of HM303-6 Boards

Preliminary note:

This short description refers to the HM303-6 block diagram. It contains the most important functions, but not all.

1 YP Board

1.1 CH1 and CH2

1.1.1 Input, High Impedance Attenuator and FET impedance converter

The measuring signal at the input is connected to the AC/DC coupling switch. Opposite to DC coupling, in AC coupling mode the DC signal content is blocked.

With GND not activated, the signal bypasses the GND (ground switch) into a switchable high impedance (1 MΩ) attenuator and enters a FET (impedance converter). If GND is selected, the signal path is interrupted and attenuator or FET input are grounded.

1.1.2 Pre-Amplifier

The next stage is the Pre-Amplifier where an additional amplification by 5 is made to enable 1 mV/cm and 2 mV/cm sensitivity.

1.1.3 Low Impedance Attenuator

The following selectable low impedance attenuators (1:1, 2:1 and 4:1); the high impedance attenuator and the Pre-Amplifier enable the selection of all Y deflection coefficients from 1 mV/cm to 20 V/cm.

1.1.4 Variable Gain and Symmetry

In the next stage (VAR. GAIN) the fixed Y deflection coefficient can also be set to uncalibrated intermediate values; unbalance can be compensated by variable balance adjustment (VAR_BAL). Additionally the signal is converted in this stage from an unsymmetrical signal into 2 symmetrical signals with a phase difference of 180°. The following stages are designed as two identical symmetrical amplifiers.

1.1.5 Trigger Pick Off, Intermediate Amplifier Driver and Invert CH II

In this stage the trigger signal is picked off and feeds the Intermediate Trigger Amplifier. The signal at the emitter drives the Intermediate Amplifier (channel II via the Inverting Switch). When activated, the Inverting Switch interchanges the 2 (180° different) measuring signals to be amplified in the following stages. The result is a 180° turned (inverted) signal display. Unbalance in the channel II stage can be compensated by the invert balance adjustment (INV_BAL2).

1.1.6 Intermediate Amplifier

This amplifier follows the inverting switch. Here the DC current of both identical amplifiers is controlled in such a way, that if the current in one amplifier is reduced it increases in the other amplifier by the same amount. This causes a trace position shift in (Y position). Time constants between both emitters are for amplifier frequency response correction.

1.1.7 Channel Switch

Thereafter the measuring signals of CH1 and CH2 are input in the Channel Switch (diode switch) of each channel. Both channel switch outputs are connected with the Y-Final Amplifier on XY Board.

1.1.8 Channel Switch Control

Depending on the current channel mode (CH I, CH II, alternating DUAL, cho_{pp}ed DUAL, XY and CT (Component Tester)) the channel switches are controlled by the Channel Mode Control stage (IC2007). This IC also controls the trigger channel switches CH I, CH II (internal triggering) and external triggering (TRIG. EXT.) and generates the cho_{pp}er signal as well as the cho_{pp}er blanking signal.

1.2 Trigger Section

1.2.1 Intermediate Trigger Amplifier CH I

The CH I measuring signal originating from the measuring amplifier (trigger pick off) is amplified in this amplifier (named TRIG.-PICK-OFF in the circuit diagram). The same IC (2004) acts as the Trigger Channel Switch CH I.

Amplifier unbalance in this stage can be compensated by DC-Triggering adjustment (P2006).

1.2.2 Intermediate Trigger Amplifier CH II

The CH II measuring signal originating from the measuring amplifier (trigger pick off) is amplified in this amplifier (named TRIG.-PICK-OFF in the circuit diagram). The same IC (2005) acts as the Trigger Channel Switch CH II.

Amplifier unbalance in this stage can be compensated by DC-Triggering adjustment (P2008).

1.2.3 External Triggering

The signal for external triggering, originating from the TRIG. EXT. input, passes a 2:1 divider and controls a FET (impedance converter). In the next stage (IC2002) the signal is converted from an unsymmetrical signal into 2 symmetrical signals with a phase difference of 180° and enters the External Trigger Channel Switch.

1.2.4 Trigger Source Selection

The Trigger Channel Switches are controlled by the Channel Mode Control stage (IC2007). The signal to be used for triggering is output at one of the trigger channel switches, connected with the Trigger Amplifier (Sync. Amp.) on TB Board.

2 XY Board

2.1 CT Switch

If CT mode is selected the channel switches CH I and CH II are closed and the Y component of the COMPONENT TESTER signal is input via the CT Switch in the following Y-Final-Amplifier.

2.2 Y Final Amplifier

The measuring signal is amplified and controls the Y plates of the cathode ray tube (CRT).

2.3 TB XY CT Switch

This switch is controlled by the mode settings and has inputs for the time base sawtooth signal, the X signal component in XY mode and the X signal in CT (COMPONENT TESTER) mode. One of these signals controls the X Final Amplifier.

2.4 X Final Amplifier & X-Pos. Control

The signal for X deflection is amplified and controls the X plates of the cathode ray tube (CRT). The gain can be switched between x1 and x10 X deflection.

A DC voltage originating from X-POS. control is also input. It enables X position shift of the trace.

3 TB Board

3.1 Sync. Amp.

The signal originating from the trigger channel switches enters this stage for additional amplification and to be changed from a symmetrical to an unsymmetrical signal.

In XY mode the output signal – originating from CH I – is used for X-Amplifier control.

3.2 LF Filter

If LF Trigger is selected a capacitor is connected between Sync. Amp. output and ground to short the higher frequencies of the trigger signal.

3.3 AC/DC Select & Line

The Sync. Amp. output signal can pass this stage via a capacitor (AC coupling) if the AC switch is on or DC coupled if the DC switch is on. In line/mains trigger mode both switches are set to off and the line/mains trigger signal is introduced at the output.

3.4 TV Sync. Separator & TV Slope Selection

The trigger signal originating from the Sync. Amp. output passes a switch if TV triggering is selected and controls one of two TV sync. pulse separator circuits; one designed for positive and the other for negative polarity sync. pulses. With correct slope selection, the relevant circuit separates the sync. pulses from the picture content. At the output a capacitor is switched to ground if time base settings suitable for frame triggering are selected. The capacitor shorts the high frequency line trigger pulses so that only the low frequency frame pulses appear at the output. If time base settings are suitable for line triggering the capacitor is switched off.

The output signal controls the Time Base Control AT/NM Trigger IC (4008).

3.5 Trigger Buffer

The signal at the AC/DC Select & Line circuit output controls the Trigger Buffer amplifier. The trigger signal at the Trigger Buffer output is connected with the following 2 stages.

3.6 P-P Trigger & Level Control

In trigger and trigger coupling modes where Peak to Peak triggering is used, the trigger signal is used to generate voltages determining the minimum and maximum voltages for the trigger level setting range. The trigger level can then be set within these limits (trigger signal height dependent), so that the trigger level is restricted to the signal height limits. Peak to Peak triggering is only enabled in automatic triggering mode.

If normal (NM) triggering is selected or operating modes where P-P triggering is switched off, the operating point of the P-P circuit is set to fixed settings with positive and negative voltages at the trigger level potentiometer that enable a level setting over the full range.

The trigger level control DC voltage sets the operating point of the trigger comparator.

3.7 Trigger Comparator

The trigger signal from the Trigger Buffer amplifier is compared with the level control DC voltage in the trigger comparator and generates a voltage change at the output each time the trigger signal crosses the reference voltage.

The output signal controls the Time Base Control & AT/NM Trigger stage.

3.8 Time Base Control & AT/NM Trigger

This circuit (IC4008) controls the sawtooth and the hold off generator, the automatic trigger generator and the trace blanking.

Input signals are the trigger comparator signal, the tv sync. pulses, the logic signals from sawtooth and hold off comparator and the $chopper$ blanking signal.

These signals and functions are controlled by the state of different modes such as trigger slope, automatic/normal trigger, CT mode, XY mode and TV trigger settings.

3.9 Sawtooth Generator (TB) & Comparator

If the trigger conditions are met, the sawtooth generator is activated so that a sawtooth is generated for X deflection – deflecting the beam from left to right; additionally the beam blanking is switched off so that the beam (trace) becomes visible. The sawtooth speed depends on the time base switch setting, which selects a capacitor to be charged by a selectable constant current source and the time base variable control.

A voltage comparator output is connected with the time base control circuit via a Flip-Flop (also connected with the hold off comparator output). When the sawtooth maximum height is reached, the sawtooth capacitor is discharged so that the beam returns to the start position on the left side of the screen. Additionally the blanking is switched on to make the beam invisible during flyback and hold off time until the hold off time has elapsed and the trigger circuit starts the sawtooth generator again.

3.10 Hold Off Generator & Comparator

At the same time as the sawtooth is discharged, the hold off generator is activated, and a capacitor is charged (time base setting dependent). The purpose is to generate a waiting time for beam flyback followed by a time in which triggering is disabled. As the duration of the hold off time is time base setting dependent, it allows constant trace intensity at all time base settings in automatic triggering condition, without signal.

A voltage comparator generates a signal when the hold off capacitor is charged to a certain value. The comparator output is connected with the time base control circuit via a Flip-Flop (also connected with the sawtooth comparator output). It generates the signal for hold off capacitor discharge and prepares for the next signal display which can only be caused by a trigger signal in normal trigger mode. In automatic mode it can be caused by a trigger signal but also by the automatic generator if no trigger signal is present.

The hold off time can be increased by the HOLD OFF control for pulse train triggering etc.

3.11 Blanking Amplifier & Intens

Blanking signal and the intensity control DC voltage are combined in this stage and control the Blanking Switch & Amplifier stage on CR Board.

4 CR Board

The CR board contains the Blanking Final Amplifier, the Blanking Switch & Amplifier, the Focus Control and the Astigmatism Adjust. stage.

5 CC Board

5.1 CALIBRATOR Signal

The $0.2V_{pp}$ calibrator signal is generated for probe adjustment purposes. It is a square wave signal that can be switched from 1 kHz (probe adaptation to the oscilloscope input capacity) to 1 MHz (probe high frequency adaptation to the oscilloscope frequency response).

5.2 COMPONENT TESTER

An oscillator generates the X and Y signal components (CTX and CTY) of the component tester (CT) that can be changed by applying electronic parts (e.g. semiconductors, resistors, capacitors etc.) to the COMP. TESTER sockets.

6 FC Board

The switches and potentiometers on this board enable the user to control the instrument.

7 PS Board

This board contains a switch mode power supply with different supply voltages for the instrument.

It also contains a -2 kV high voltage generator required for cathode ray tube (CRT) operation. The voltage for the CRT heater is generated by separate, isolated windings of the switch mode power supply transformer as it is connected with -2 kV.

PCB Interconnections

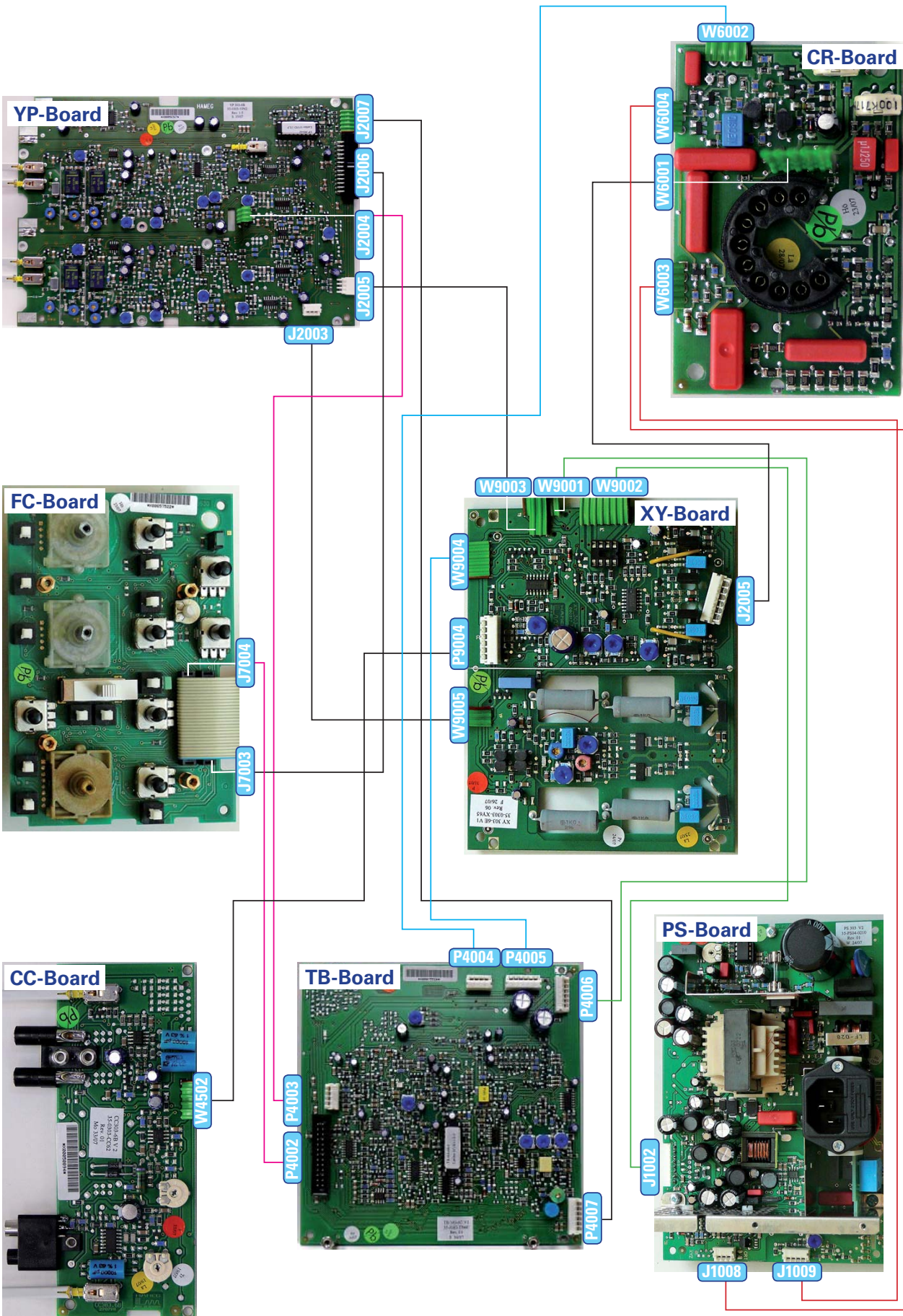

Interconnections between:

YP-Board (J2006) and FC-Board (J7003)

Direction	Pin	Name
	1	GND
←--	2	CH_1/2
←--	3	ADD
←--	4	DUAL
←--	5	ALT/CHOP
←--	6	~TR_EX~
←--	7	~ALT_TRIG~
	8	GND
←--	9	Y2_POS
←--	10	Y2/100
←--	11	Y2/10
←--	12	Y2/2
←--	13	Y2/1
←--	14	Y2x5
←--	15	Y2_VAR
	16	GND
←--	17	Y1_POS
←--	18	Y1/100
←--	19	Y1/10
←--	20	Y1/2
←--	21	Y1/1
←--	22	Y1x5
←--	23	Y1_VAR
-->	24	-6V
-->	25	+5V
-->	26	+12V

YP-Board (J2007) and TB-Board (J4007)

Direction	Pin	Name
	1	~CT~
-->	2	~XY~
-->	3	CHBL
-->	4	~ALT_TRG~
	5	GND
←--	6	AMP

YP-Board (J2004) and MB-Board (P4003)

Direction	Pin	Name
	1	GND
-->	2	SY_1
-->	3	SY_2
	4	GND

YP-Board (J2008) and XY-Board (W9003)

Direction	Pin	Name
←--	1	+5V
←--	2	+12V
←--	3	-6V

YP-Board (J2003) and XY-Board (W9005)

Direction	Pin	Name
-->	1	no name (Y signal to Y final amplifier)
	2	GND
-->	3	no name (Y signal to Y final amplifier)

FC-Board (J7004) and TB-Board (P4002)

Direction	Pin	Name
-->	1	LEVEL
-->	2	LL_P
-->	3	LL_N
-->	4	SLOPE_P/~N~
-->	5	DC_ON
-->	6	TV_ON
-->	7	LF_ON
-->	8	TRIG_AT/~N~
-->	9	AC_ON
-->	10	TR_LED
-->	11	~SR1~
-->	12	SR2
-->	13	~LINE~
-->	14	~SR5~
-->	15	~XY~
-->	16	~SR10~
-->	17	~SC2~
-->	18	~SH0~
-->	19	~SC3~
-->	20	T_VAR
-->	21	~X_MAG~
-->	22	HOFF_VAR
-->	23	nc
-->	24	X_POS
-->	25	FOCUS
-->	26	INT_S

YX-Board (W9001) and TB-Board (P4006)

Direction	Pin	Name
←--	1	+5V
←--	2	LINE_TR
←--	3	+12V
←--	4	-CT_V
←--	5	-6V
←--	6	GND

XY-Board (W9004) and TB-Board (P4005)

Direction	Pin	Name
←--	1	XY_X
←--	2	~XY~
←--	3	XPOS
←--	4	~CT~
←--	5	AS_X
←--	6	~XMAG~

XY-Board (P9003) and CR-Board (W6001)

Direction	Pin	Name
-->	1	no name (to X plate 1, CRT)
←--	2	nc
←--	3	+146V (YDV)
←--	4	+175V (XDV)
←--	5	nc
-->	6	no name (to X plate 2, CRT)

TB-Board (P9004) and CR-Board (W6002)

Direction	Pin	Name
-->	1	+12V
-->	2	Blank
-->	3	GND
-->	4	FOC_CTRL

PS-Board (J1009) and CR-Board (W6003)

Direction	Pin	Name
-->	1	HT-2
-->	2	HT-1
-->	3	-2kV
-->	4	FOCUS

PS-Board (J1008) and CR-Board (W6004)

Direction	Pin	Name
-->	1	50V
-->	2	PUMP_VOL
-->	3	GND

XY-Board (W9002) and PS-Board (J1002)

Direction	Pin	Name
←--	1	+175V
←--	2	+146V
←--	3	GND
←--	4	+5.2V
←--	5	LINE_TR
←--	6	+12V
←--	7	CT_V
←--	8	-6V

Board Replacement

Preliminary note!

Although all PCBs have been tested by HAMEG, adjustment is required after replacement, due to unavoidable tolerances.

PS Board

- 1 Before removing the PS board, check that the power cable is not connected to the oscilloscope.

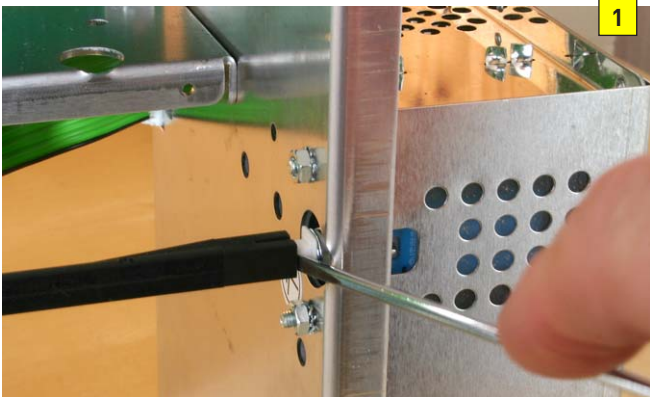

- 2 Remove the power rod from the power switch.



- 3 Press connector "A" and pull the ribbon cable (out).
- 4 Press connector "B" and pull the ribbon cable (out).
- 5 Remove the 5 screws marked "C" and remove the protection (screening) shield.

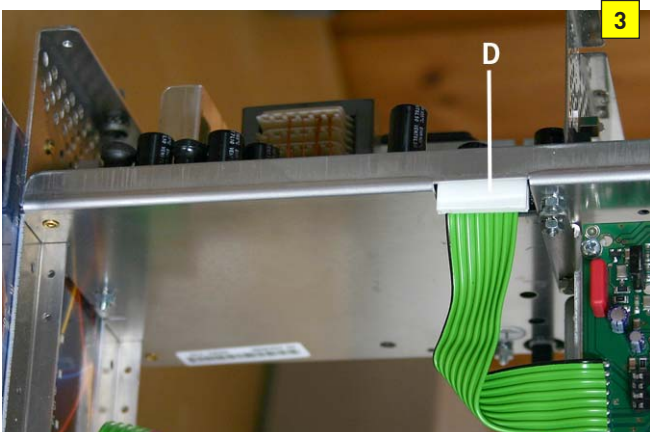

- 6 Press connector "D" and pull the ribbon cable (out).

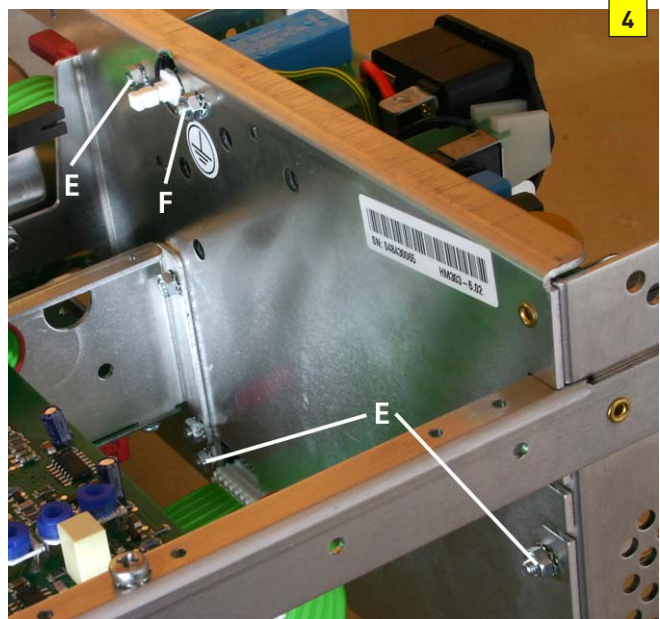

- 7 Remove the 3 nuts marked "E".

Attention!
Do not unscrew the 3 screws marked "X" in fig. 1.5!

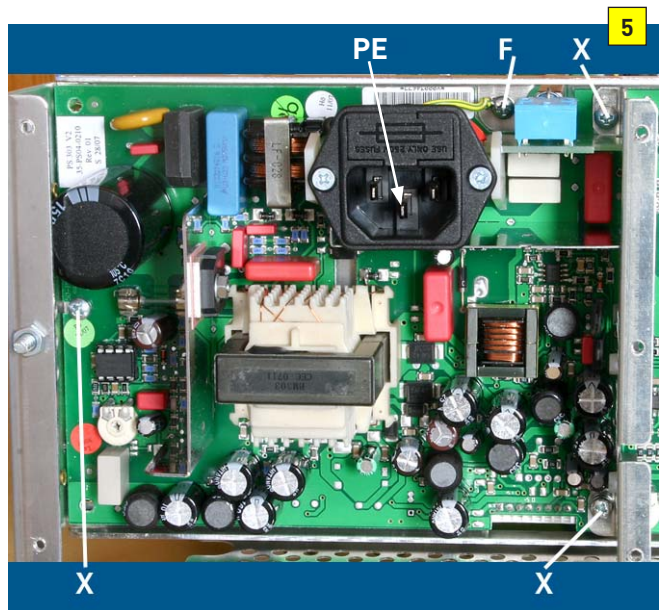

- 8 Remove screw and nut marked "F" (fig. 4 and 5).

Attention!
This screw connects the protective ground line with the chassis.
After insertion of the new PS board, firstly this screw must be used to connect the protective ground line with the chassis. A secure connection must be made, which can only be broken by using a tool!

- 9 Replace the PS board and check that the isolation plate between the PS board soldering side and the rear chassis is still present. Then follow the previous instructions in

reverse order, but do not fit the protection (screening) shield.

- 10 Measure the resistance between the power socket centre connector marked "PE" and the rear chassis using an Ohm meter. If the resistance is less than 1 Ohm continue the fitting procedure. Otherwise check the protective earth circuit, and repair it until the requirement of less than 1 Ohm between power socket PE and rear chassis is met.
- 11 Connect power cable to the oscilloscope and switch it on.
- 12 Follow the Adjustment Procedure HM303-6 in the following order (item):
 - 1) RV1001: Adjustment of +146 Volt supply
 - 2) +175 Volt check
 - 3) RV1003: Adjustment of +12 Volt supply
 - 4) -6 Volt accuracy check
 - 5) Y plate voltage check
- 13 Due to the influence of the supply voltages on all circuitry, it is recommended to make a complete Performance Check as described in this Service manual.

FC Board

- 1 Before removing the FC board, check that the power cable is not connected to the oscilloscope.

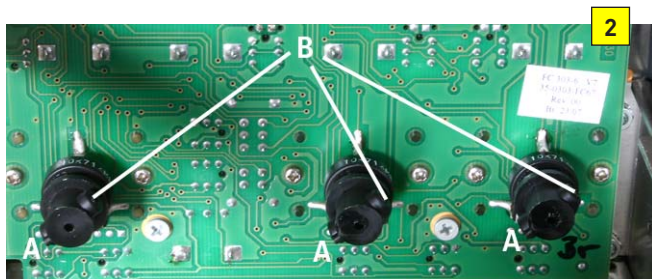
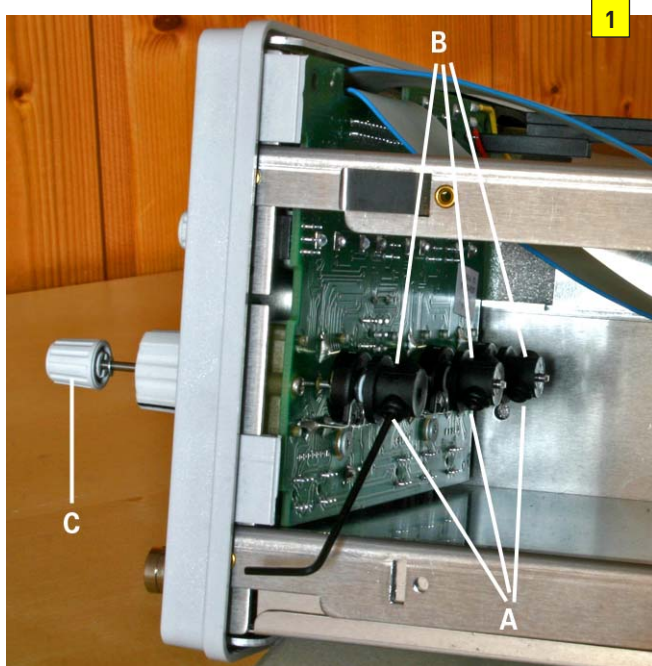

- Turn the 3 variable knobs (arrow marking) from their calibrated detent to a position where the hexagon sockets

marked "A" - which may not have been accessible - can be unfastened.

- Turn the 3 variable knobs (arrow marking) back to their calibrated detent and unfasten the hexagon sockets marked "B" which are accessible in this position.
- Remove the 3 variable knobs (now unfastened) together with their shafts (the visible one marked "C").



- 2 Remove all knobs and note that the FOCUS knob is the only knob without marking.

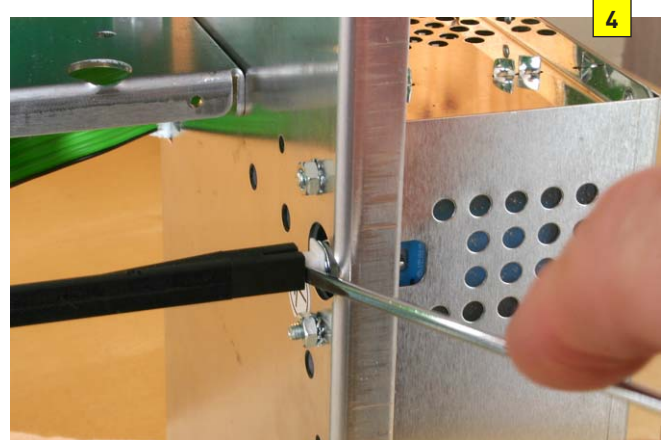

- 3 Remove the power rod from the power switch and pull off the red power pushbutton.

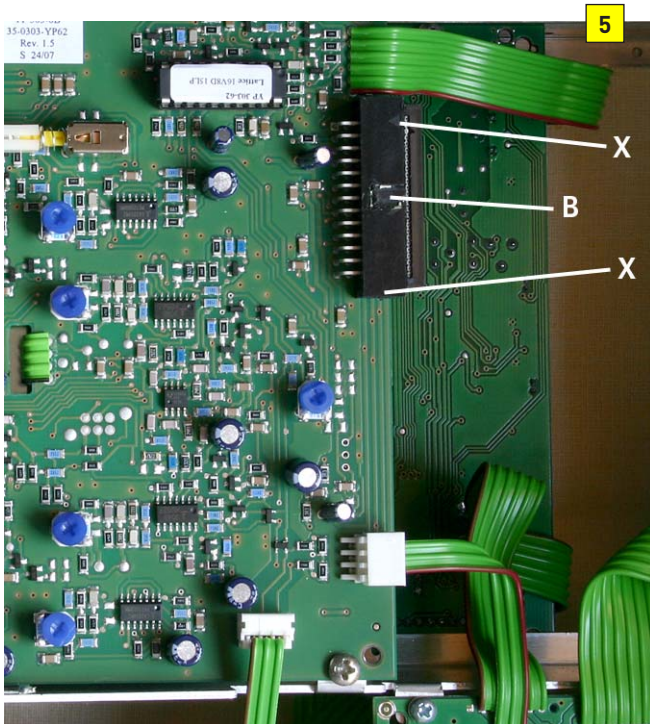

- 4 Locate the long ribbon cable connecting the FC and the YP board. Remove the glue (transport protection) from the connector "B", use a screwdriver as a lever and position it in the gap to press the connector out while slightly pulling at the ribbon cable.

Note!

Pulling at the ribbon cable or using a screwdriver at the edges marked "X" may damage the plug.

- 5 Remove the short ribbon cable plug from the socket on the TB board.



- Release the front panel mounting points on one side, using a screwdriver as a lever.
- Turn the oscilloscope and release the front panel mounting points as before.
- Carefully pull off the front panel.

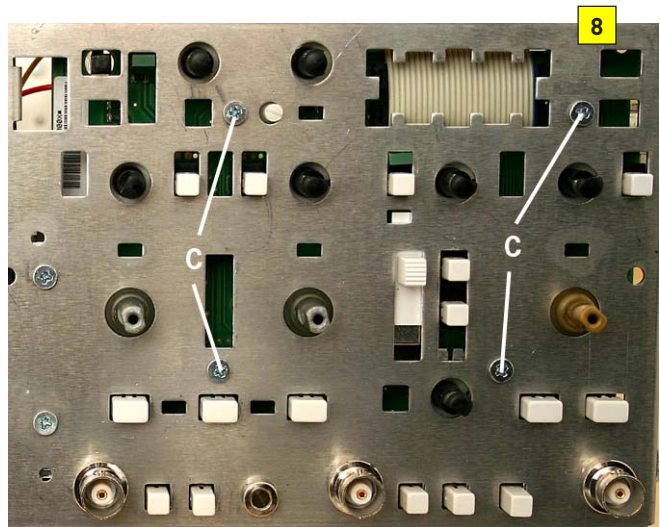

- 6 Remove the 4 screws marked "C".

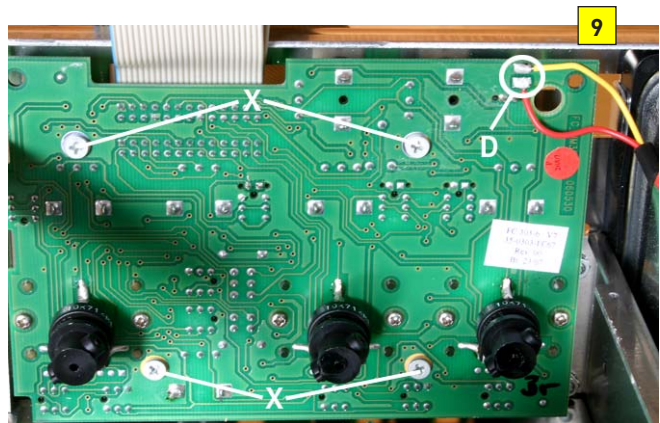

- 7 Unsolder the trace rotation coil wires marked "D" and keep the colour allocation in mind.

Attention!

Do not unscrew the 4 screws marked "X" in fig. 9!

- 8 Replace the FC board and follow the previous instructions in opposite order.

Note!

Before inserting the variable knobs shafts, check that the potentiometers are in calibrated detent position. Thereafter insert the shafts completely and turn the variable knobs clockwise until the arrow symbols point to the right. Then fasten the shafts using the hexagon sockets accessible in this position. Turn the variable knobs counter clockwise (ccw) until the unfastened hexagon sockets can be fastened.

- 9 Connect power cable to the oscilloscope and switch it on.
- 10 Due to tolerances of the potentiometers please follow the instructions of the Adjustment Procedure HM303-6 in the following order (item):

- 1) RV1001: Adjustment of +146 Volt supply
- 2) +175 Volt check
- 3) RV1003: Adjustment of +12 Volt supply
- 4) -6 Volt accuracy check
- 6) R6013: CRT minimum intensity
- 10) P2007: Y-Gain CH I at 5 mV/div
- 17) P2011: Y-Gain CH II at 5 mV/div
- 28) CV4001: 0.1 μ s/div time base adjustment
- 29) RV4004: 50 μ s/div time base adjustment
- 30) RV4003: 50 ms/div time base adjustment
- 34) RV4001: Trigger-Symmetry
- 40) VR7003: Trace Rotation Check

- 6 Please follow the instructions of the Adjustment Procedure HM303-6 in the following order (item):
 - 1) RV1001: Adjustment of +146 Volt supply
 - 2) +175 Volt check
 - 3) RV1003: Adjustment of +12 Volt supply
 - 4) -6 Volt accuracy check
 - 40) VR7003: Trace Rotation check
 - 41) RV4501: Component-Tester trace inclination
 - 42) RV4502: Calibrator Output

CC Board

- 1 Before removing the CC board, check that the power cable is not connected to the oscilloscope.

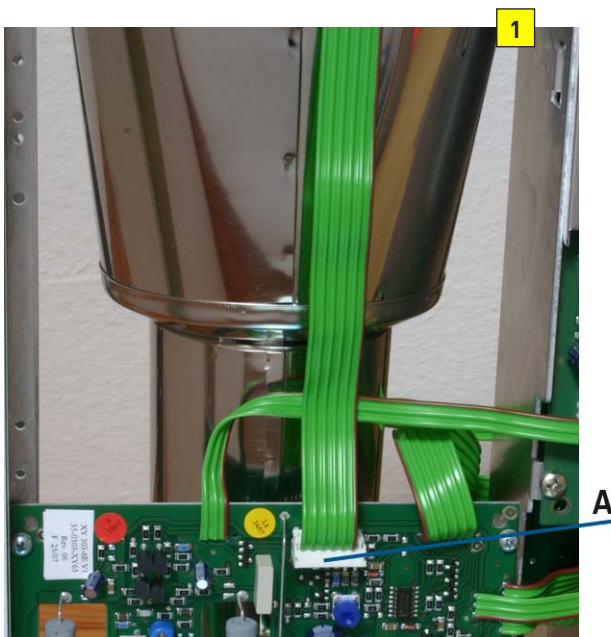

- 2 Press connector "A" on XY board and pull the ribbon cable (out).

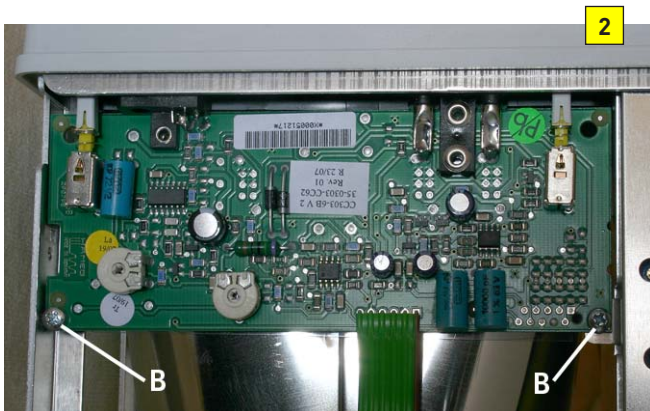

- 3 Remove the 2 screws marked "B" and carefully pull the CC board (out).
- 4 Replace the CC board and follow the previous instructions in reverse order.
- 5 Connect power cable to the oscilloscope and switch it on.

YP Board

- 1 Before removing the YP board, check that the power cable is not connected to the oscilloscope.

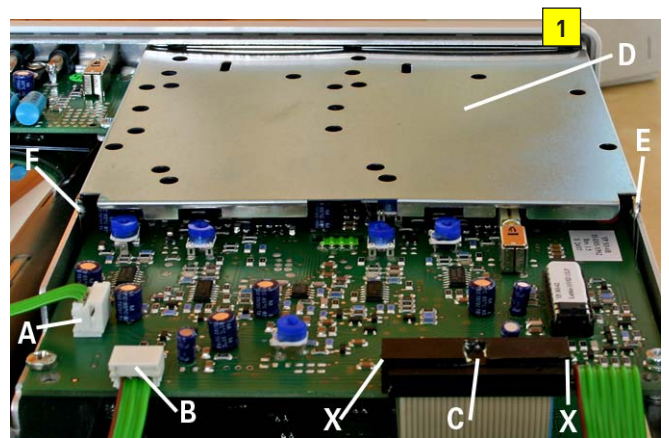

- 2 Press connector "A" and pull the ribbon cable (out).
- 3 Press connector "B" and pull the ribbon cable (out).
- 4 Remove the glue (transport protection) from the connector "C", use a screwdriver as a lever and position it in the gap to press the connector out while slightly pulling at the ribbon cable.

Note!

Pulling at the ribbon cable or using a screwdriver at the plug edges marked "X" may damage the plug.

- 5 Unsolder the YP board screening plate lugs "D" at the position "E" and "F" and pull the plate to remove it.



- 6 Locate TB board, press connectors "A" and "B" and pull the ribbon cables (out).

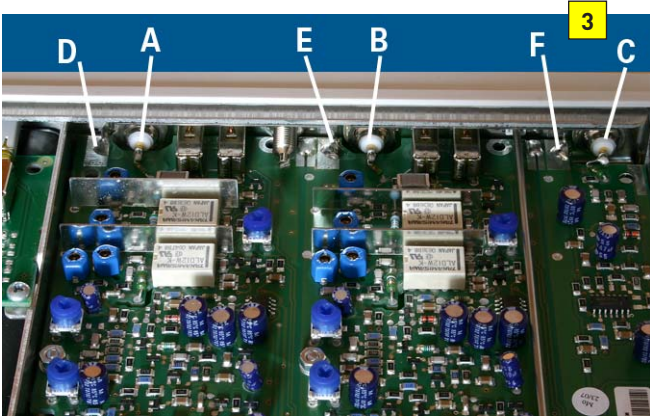

- 7 Unsolder the resistors at the BNC sockets "A", "B" and "C" and bend their leads away from the sockets.
- 8 Unsolder the 3 steel plate angles marked "D", "E" and "F" where soldered on the YP board.

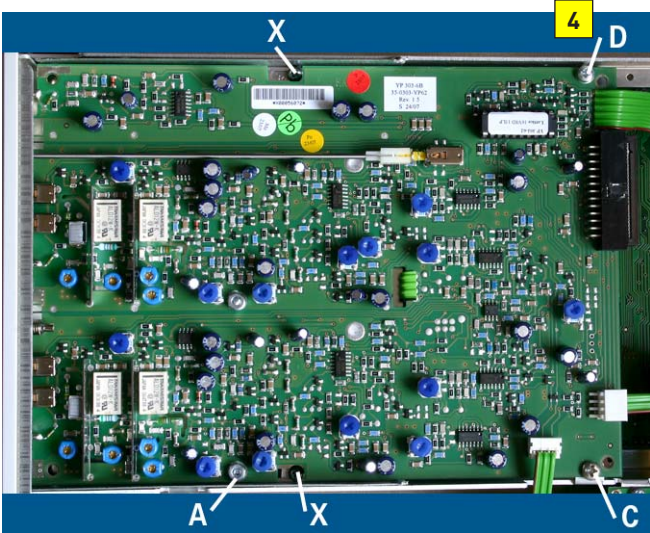

- 9 Remove the nuts "A" and "B".
- 10 Remove the screws "C" and "D".

Attention!

Do not unscrew the 2 screws marked "X" in fig. 4!

- Lift the YP board at the rear so that the screws (where the nuts "A" and "B" were mounted before) do not obstruct the YP board removal.
- Replace the YP board and follow the previous instructions in reverse order.
- Connect power cable to the oscilloscope and switch it on.
- Please follow the instructions of the Adjustment Procedure HM303-6 and make a complete adjustment from item 1 to item 42.

XY Board

- 1 Before removing the XY board, check that the power cable is not connected to the oscilloscope.

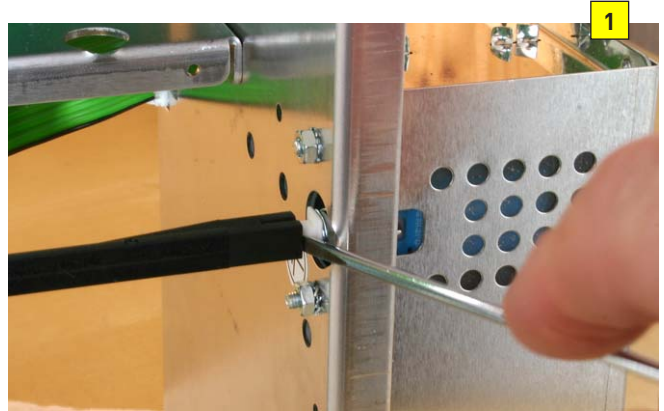

- 2 Remove the power rod from the power switch.



- 3 Locate and identify TB board, press connectors "A" and pull the ribbon cables (out).

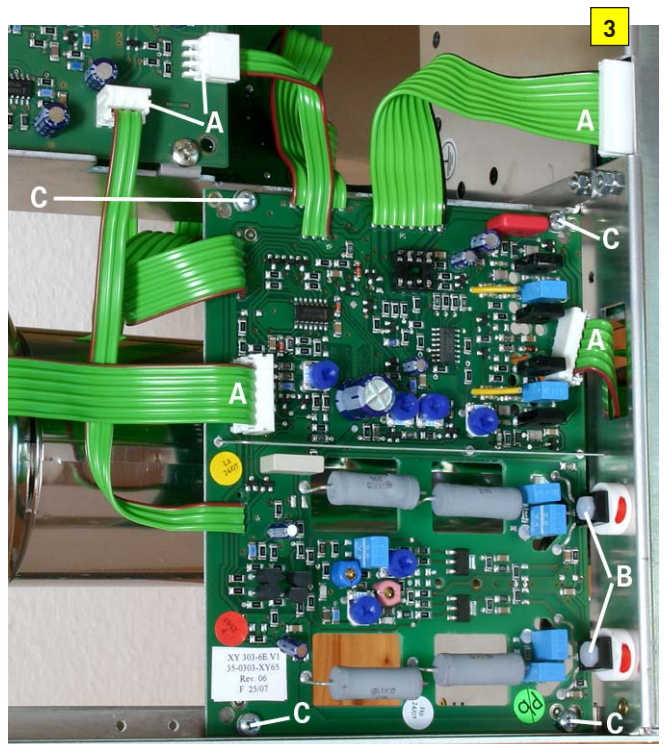

- 4 Press connectors "A" and pull the ribbon cables (out).

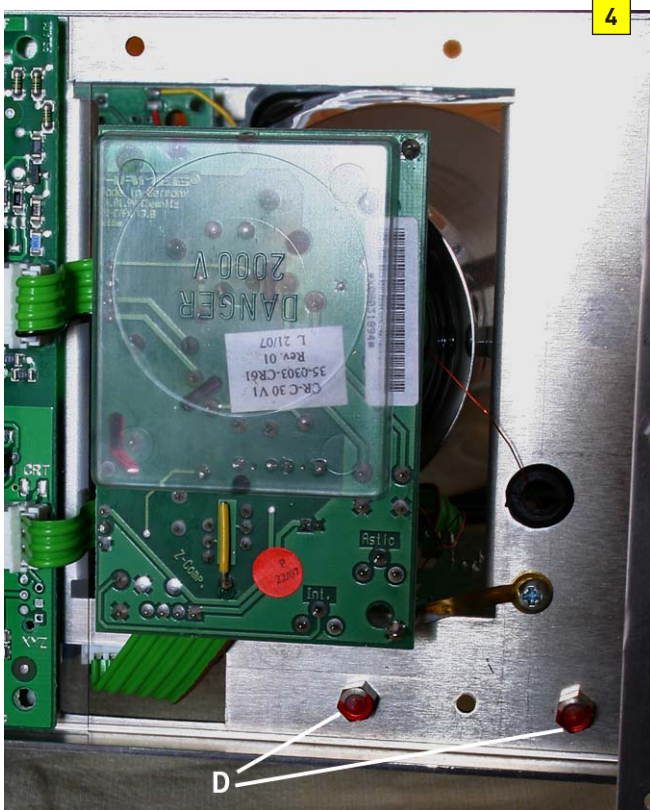

- 5 After unscrewing the nuts "D", accessible on the rear side of the rear chassis, carefully remove the plastic screws "B" and remove the white ceramic spacer discs (isolation and heat sink).

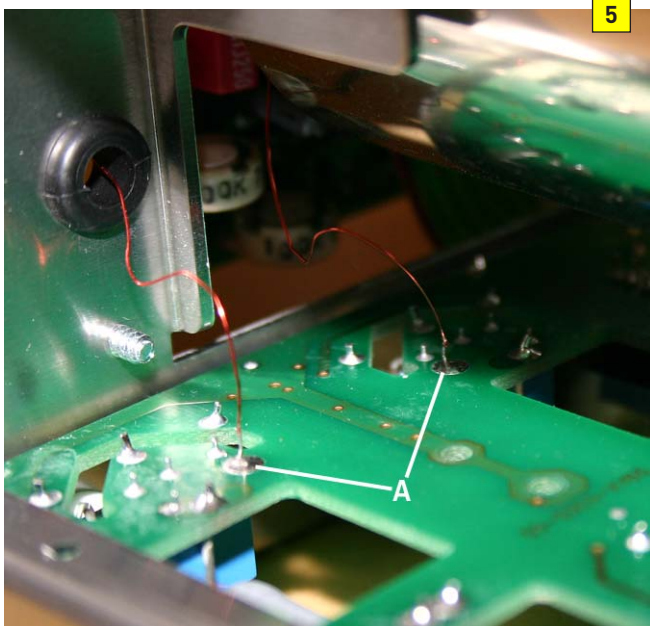

- 6 Unsolder the 2 wires marked "A" on the bottom of the XY board.
- 7 Replace the XY board and follow the previous instructions in reverse order.
- 8 Connect power cable to the oscilloscope and switch it on.
- 9 Please follow the instructions of the Adjustment Procedure HM303-6 in the following order (item):
- 1) RV1001: Adjustment of +146 Volt supply
 - 2) +175 Volt check

- 3) RV1003: Adjustment of +12 Volt supply
- 4) -6 Volt accuracy check
- 10) P2007: YGain CH I at 5 mV/div
- 11) P2002: YGain CH II at 5 mV/div
- 25) P2012: ADDition balance
- 32) CV9001/9002, RV9006/9005: Y-Final Amplifier
- 38) Y-Amplifier Bandwidth Check
- 39) RV9001: Component-Tester Y-Offset and
- 26) RV4005: Sawtooth start position
- 27) RV9004: X-Magnification x1
- 31) RV9003: X-Magnification x10
- 32) C9026, C9027: X-Magnification x10 linearity
- 33) RV9002: X-Gain Adjustment in XY-Mode

TB Board

- 1 Before removing the TB board, check that the power cable is not connected to the oscilloscope.

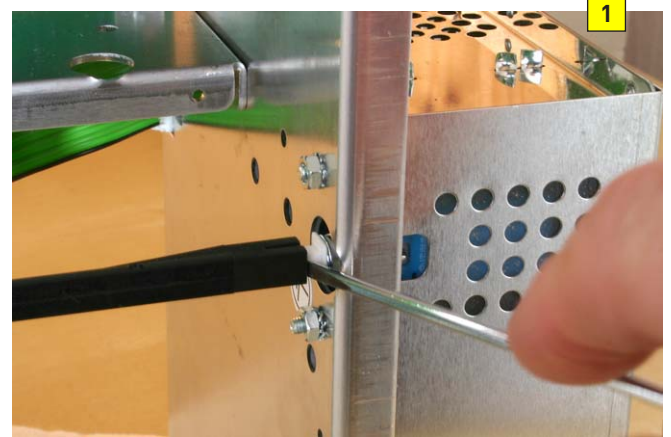

- 2 Remove the power rod from the power switch.

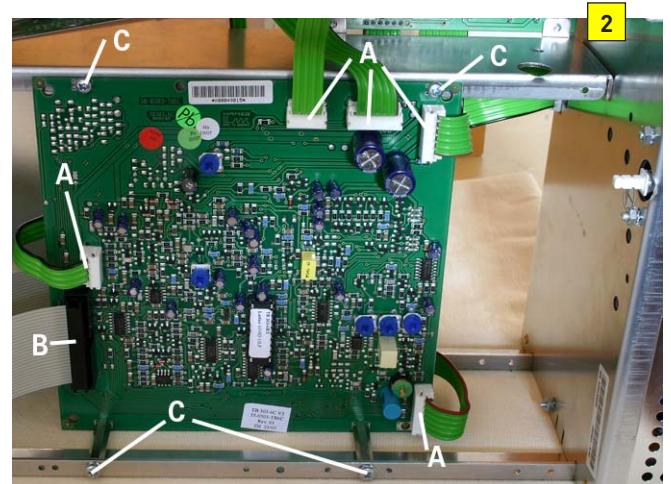

- 3 Press connectors marked "A" and pull the ribbon cables (out).
- 4 Pull connector "B" (out).
- 5 Remove the 4 screws marked "C".
- 6 Replace the TB board and follow the previous instructions in reverse order.
- 7 Connect power cable to the oscilloscope and switch it on.

- 8 Please follow the instructions of the Adjustment Procedure HM303-6 in the following order (item):
- 1) RV1001: Adjustment of +146 Volt supply
 - 2) +175 Volt check
 - 3) RV1003: Adjustment of +12 Volt supply
 - 4) -6 Volt accuracy check
 - 9) RV4002: Focus control
 - 34) RV4001: Trigger-Symmetry
 - 35) P2006: DC-Trigging CH I
 - 36) P2008: DC-Trigging CH II
 - 26) RV4005: Sawtooth start position
 - 27) RV9004: X-Magnification x1
 - 28) CV4001: 0.5 μ s/div time base adjustment
 - 29) RV4004: 50 μ s/div time base adjustment
 - 30) RV4003: 50 ms/div time base adjustment
 - 31) RV9003: X-Magnification x10
 - 33) RV9002: X-Gain Adjustment in XY-Mode

CR Board

- 1 Before removing the CR board, check that the power cable is not connected to the oscilloscope.



- 2 Locate and identify TB board, press connector "A" and pull the ribbon cable (out).

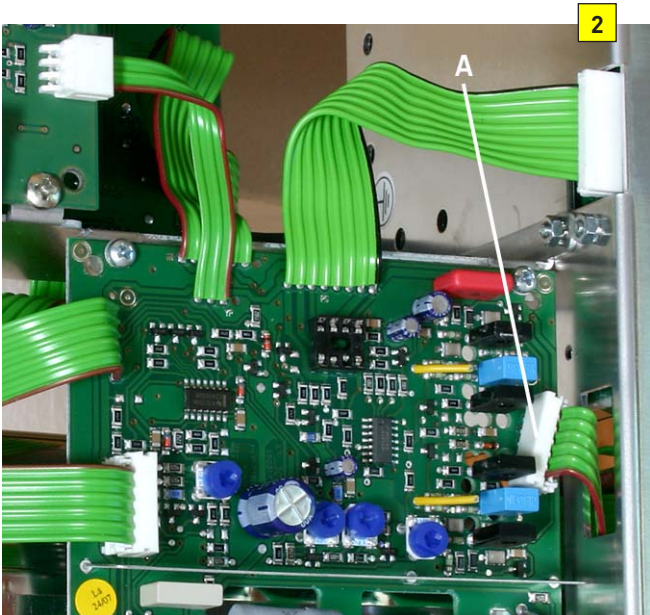

- 3 Locate and identify XY board, press connector "A" and pull the ribbon cable (out).



- 4 Locate and identify PS board, press connectors "A" and pull the ribbon cables (out).
- 5 Unsolder soldering lug marked "B".
- 6 Replace the CR board and follow the previous instructions in reverse order.
- 7 Connect power cable to the oscilloscope and switch it on.
- 8 Please follow the instructions of the Adjustment Procedure HM303-6 in the following order (item):
- 1) RV1001: Adjustment of +146 Volt supply
 - 2) +175 Volt check
 - 3) RV1003: Adjustment of +12 Volt supply
 - 4) -6 Volt accuracy check
 - 6) R6013: CRT minimum intensity
 - 7) RV1005: Focus symmetry
 - 8) R6024: Astigmatism correction

HM303-6 Troubleshooting

Security advice!

The following procedures assume that the instrument is connected to mains/line via a safety class II transformer. Only qualified personnel (technicians and engineers) who are aware of the danger of electricity should execute the following procedures.

If cables or connectors have to be disconnected, the instrument must be switched off before removing them!

For measurement at high voltage (-1.5 kV focus and -2 kV acceleration voltage) use suitable probes, recommended by HAMEG.

Such measurements should be performed in the following way:

1. Switch the oscilloscope off.
2. Connect measuring instrument reference potential connector to chassis.
3. Connect the probe tip of the measuring instrument to the measuring point.
4. Switch the oscilloscope on.
5. Before removing the measuring instrument connections, switch the oscilloscope off again.

1 Opening the Oscilloscope

- 1.1 Place the oscilloscope upside down, set the handle in the maximum position to the rear, then pull on both handle knobs outward and remove the handle. (Photo 1.1 and 1.2)



- 1.2. Unscrew the nuts and remove the back panel. (Photo 1.3, 1.4, 1.5 and 1.6)



1.3. Set the front face of the oscilloscope on a soft surface and pull the cabinet off. (Photo 1.7, 1.8 and 1.9)



 Please note:
After repair work, close the instrument in reverse order of above.

2 Preliminary Tests

The precondition for undistorted operation is correct supply voltages generated by the power supply. It is highly recommended to check the power supply output voltages before any other action.

The following steps show you what to do.

2.1 Miscellaneous voltages

Locate and identify a Molex 8 pole connector J1002 (at the inner side of the vertical rear chassis) where an 8 pole ribbon cable coming from the MB board is connected. See photo 2.1.

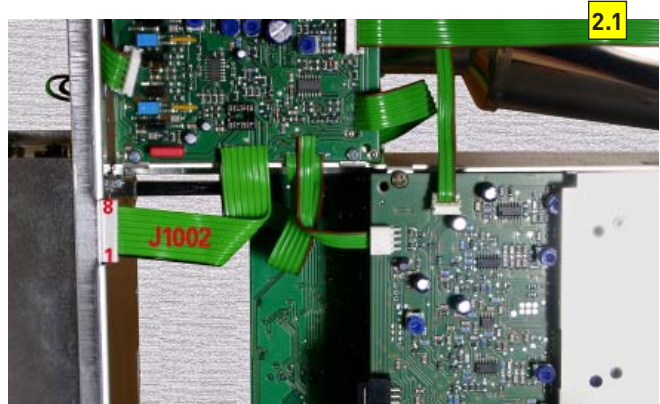

All voltages are measured with respect to ground (chassis).

The following voltages must be present:

- Pin 1: approx. +175 V
- Pin 2: +146 V (± 0.5 V)
- Pin 4: approx. +5.2 V
- Pin 6: +12 V (± 50 mV)
- Pin 8: approx. -6 V

2.2 "Pump Voltage"

Locate and identify Molex connector J1008 pin 2 (3 wires) connecting the power supply with the CR board by a ribbon cable and measure at the centre lead. See photo 2.2 and 2.3

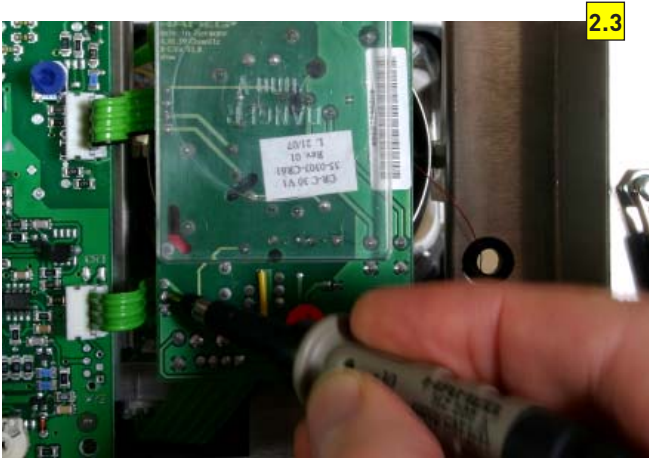

Measure the "Pump Voltage" using an oscilloscope. See photo 2.4 and 2.5

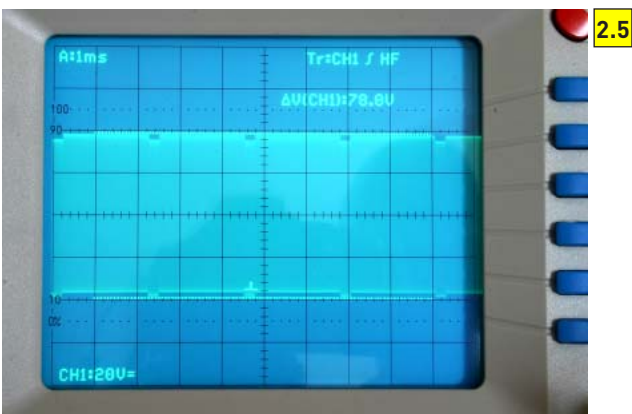
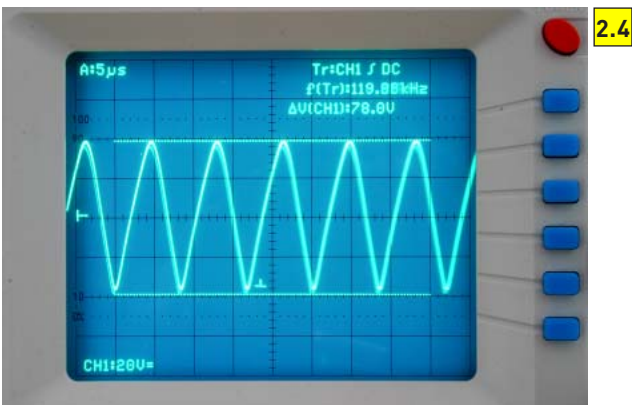

Note: The pump voltage indicates the switch mode power supply switching frequency.

2.3 -2 kV

Locate and identify Molex connector J1009 (4 wires) connecting the power supply board with the CR board by a ribbon cable. See photo 2.6

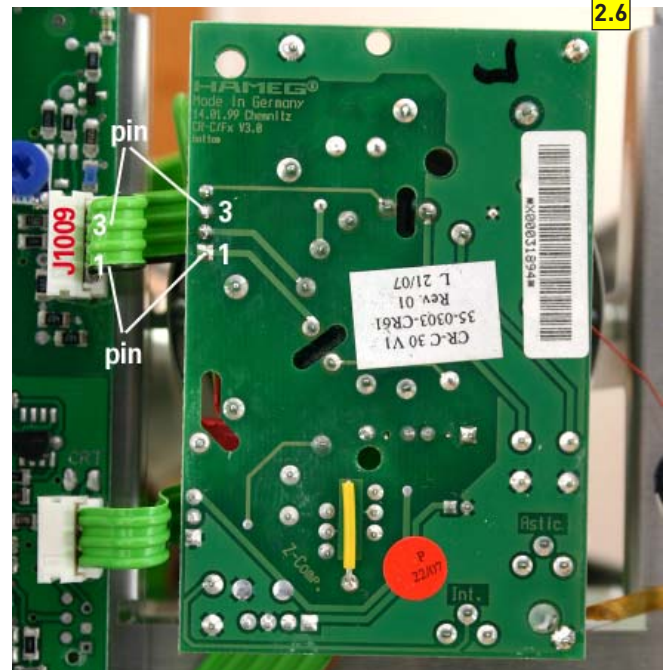

Check that the probe and the measuring instrument are suitable for measuring voltages up to 2.5 kV. Measure approx. -2 kV at pin 3 or the appropriate wire on the CR board.

2.4 Focus Voltage

Locate and identify Molex connector J1009 (4 wires) connecting the power supply board with the CR board. See photo 2.7

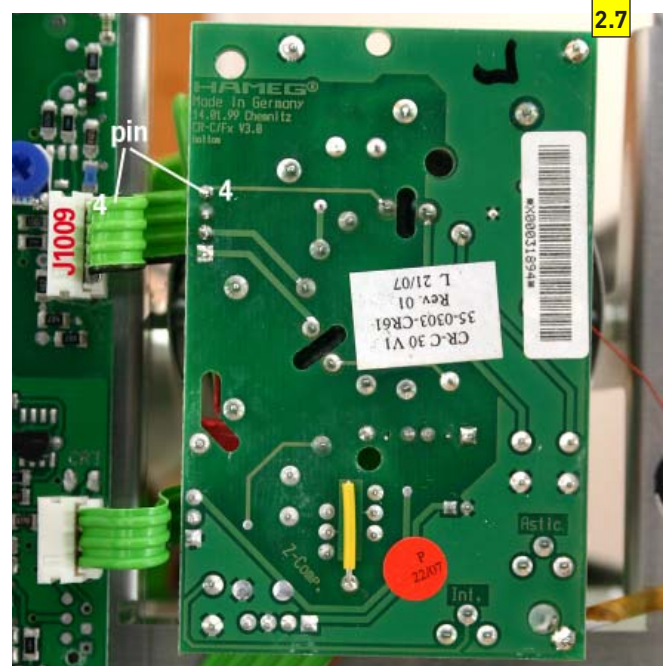

Check that the probe and the measuring instrument are suitable for measuring voltages up to 2.5 kV. Measure approx. -1.5 kV at pin 4.

2.5 CRT Heater

Look between the CRT mu-metal shielding and the CR board to see whether the heater (filament) glows.

 **Attention:**

The heater voltage is superimposed on -2 kV.

Note:

If all measurements and tests have been completed successfully except this item, switch the oscilloscope off. Locate and identify Molex connector J1009 (4 wires) connecting the power supply board with the CR board. See photo 2.8

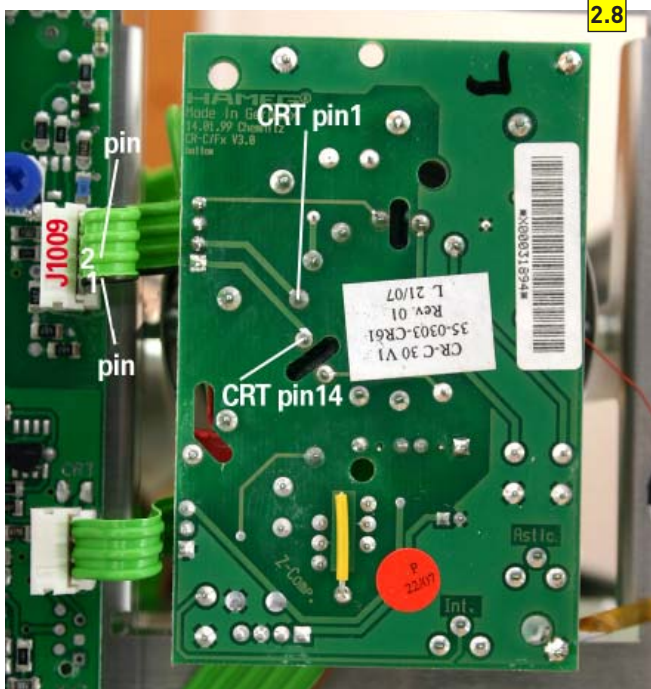

- Disconnect the ribbon cable from J1009.
- Use an Ohm meter to measure approx. 15 Ohm between wire 1 and 2 leading to pin 1 and 14 (heater) of the CRT.
- If the heater seems to be defective, remove the CRT socket and measure the CRT heater resistance between pin 1 and 14. to eliminate the CRT socket.

2.6 Measurements

If any of these voltages are missing or incorrect, the following procedure is recommended:

- Disconnect the instrument from mains/line.
- Remove the power supply shielding.
- Unsolder the wire soldered to the protective earth (PE) connection at the inner side of the rear chassis, marked by an earth symbol.
- Remove all cables and wires connected to the power supply.
- Unfasten the power supply mounting screws.
- Remove the power supply and replace it by a new power supply.

Proceed in reverse order to mount the new power supply.

 **Attention!**

Special care must be taken for the protective earth connection (PE). It must be fixed and thereafter soldered in such a way that even accidental contact with a soldering iron does not open the connection.

Security check!

Check that after PS board replacement the protective earth connection is re established.

2.7 Adjustment after power supply change.

The following procedures are required after changing a power supply due to tolerances.

- Check and adjust +146 V and +12V as described under item 1 and 2 in the Adjustment Procedure.
- Follow the instructions of the Performance Check HM303-6.

3 Error Diagnostics!

The following examples will help you to determine the board to be replaced or repaired. Due to each board's comprehensive functions it is not always possible to determine one board precisely. Thus it might be necessary to change more than one board.

As explained before under item 2, the power supply check has the highest priority.



Attention! It is recommended to reinstall the old board if a new board did not solve the problem.

Item	Behavior of the Instrument	Possible Reason / What to do	Remark
3-1.1	POWER LED not lit and no trace visible on the screen.	Pull out fuse holder and check the (external accessible) fuse. If the fuse is blown, replace it and switch the instrument on again. If the error is still present, and the (external accessible) fuse is blown again, continue with item 3-1.3. If the (external accessible) fuse is not blown, continue with item 3-1.2.	The instrument must be disconnected from mains/line before checking the fuse.
3-1.2		Remove the power supply shielding as described under item B1.6 and check the (internal accessible) fuse on the PS board. If the fuse is blown, replace it and switch the instrument on again. If the error is still present, and the (internal accessible) fuse is blown again, continue with item 3-1.3.	The instrument must be disconnected from mains/line before checking the fuse.
3-1.3		Replace the power supply as described under item 2.6 and adjust the new power supply (see item 2.7 in chapt. Troubleshooting).	
3-1.4		Security check! Check that after PS board replacement the protective earth connection is re established.	

Item	Behavior of the Instrument	Possible Reason / What to do	Remark
3-2.1	No trace visible on the screen. POWER LED lit.	Release all pushbuttons (out) except the POWER pushbutton. Set all knobs with an arrow marking to their calibrated detent. Set HOLD OFF knob to x1 position. Set the other knobs to midrange position. If the trace is still not visible continue with item 3-2.2.	
3-2.2		Press the CHI/II pushbutton to switch over for channel II operation. If the trace is not yet visible continue with item 3-2.6. If the trace is visible, locate and identify the Y-POS. I potentiometer centre connector on the soldering side of the FC board. Measure 0 to +12 Volts dependent on the setting and set it to +6 Volt. If this can be achieved, continue with item 3-2.3 If the voltage cannot be set to values between approx. +3.5 and approx. +8.1 Volt (where the trace would be within the graticule) continue with item 3-2.4.	
3-2.3		As the Y position control voltage for channel I is present, the absence of the trace in channel I mode must be caused by an error in the channel I pre-amplifier stage, channel mode control or channel switch. As all circuits are on YP board, replace this board as described in Board Replacement section.	
3-2.4		Replace the FC board as described in the Board Replacement section.	

Item	Behavior of the Instrument	Possible Reason / What to do	Remark
3-2.6		Check the power supply output voltage as described from item B.1.1 to item B.1.5 and continue with the following instructions in that section if an error is present. If the power supply output voltages are OK, continue with item 3-2.7.	
3-2.7		Switch the oscilloscope off before continuing with item 3-2.8.	
3-2.8		Remove the CR board plastic protection cover and make a short between pin 2 (cathode) and pin 3 (grid 1).	See photo 3-2.8.
3-2.9		Switch the oscilloscope on and watch if the trace becomes visible with very high intensity. If the trace is not visible, switch the oscilloscope off, do not remove the short and continue with item 3-2.10. If the trace is visible, continue with item 3-2.16.	No potential difference between cathode and grid causes maximum beam current in the crt and should be limited to a few seconds.
3-2.10		Make additionally a short between crt pins 11 and 13 (both X deflection plates) and switch the oscilloscope on. As no signal is applied at the INPUT CH I, a bright spot should become visible in the screen centre. If the spot is not visible switch the oscilloscope off, do not remove both shorts and continue with item 3-2.11. If the trace is visible, continue with item 3-2.19.	See photo 3-2.10. No potential difference between the X deflection plates means that the beam is undeflected in the horizontal centre, but can still be off screen in vertical (Y) direction.
3-2.11		Make an additional short on XY board (soldering side) between both wires from the Y final amplifier connected to the crt Y deflection plates and switch the oscilloscope on. If even under these conditions no spot is visible although the crt heater (filament) glows, cathode and grid 1, the X deflection and the Y deflection plates are shorted, the crt must be defective. Continue with item 3-2.23. If the spot is visible switch the oscilloscope off, remove the both shorts on CR board and the short on XY board. Continue with item 3-2.12.	See photo 3-2.11.



photo 3-2.8



photo 3-2.10



photo 3-2.11

Item	Behavior of the Instrument	Possible Reason / What to do	Remark
3-2.12		<p>Locate and identify the connector J2003 on YP board.</p> <p>Short the outer leads of the 3 pole ribbon cable, so that the symmetrical Y final amplifier gets the same input voltage and current.</p> <p>If the trace is visible, continue with item 3-2.13.</p> <p>If the trace is still not visible, continue with item 3-2.14.</p>	<p>See photo 3-2.12.</p> <p>Instead of shorting the outer leads it is also possible to press the connector and pull the ribbon cable [out]; without any connection. If the Y final amplifier is OK the trace will become visible but not focused as the medium plate voltages are wrong (approx. +146 V instead of +85 V) causing a wrong crt operating point.</p>
3-2.13		Replace the YP board as described in the section Board Replacement.	
3-2.14		<p>Replace the XY board as described in the section Board Replacement.</p> <p>If the trace is not visible, continue with item 3-2.15.</p>	
3-2.15		Replace the CC board as described in the section Board Replacement.	
3-2.16		<p>Locate and identify the connector J2003 on YP board.</p> <p>Press the connector and pull the 4 pole ribbon cable [out].</p> <ul style="list-style-type: none"> - If the trace is visible, continue with item 3-2.17. - If the trace is not visible continue with item 3-2.18. 	
3-2.17		Replace the TB board as described in the section Board Replacement.	
3-2.18		Replace the CR board as described in the section Board Replacement.	
3-2.19		Locate and identify connector P4005 on TB board.	
3-2.20		<p>Measure the sawtooth signal (AS_X) using an oscilloscope with a *10 probe at pin 5 of P4005.</p> <p>If the signal is present, continue with item 3-2.21.</p> <p>If the signal is not present, continue with item 3-2.22.</p>	<p>Photo 3-2.20.1</p> <p>Photo 3-2.20.2</p>
3-2.21		Replace the TB board as described in the section Board Replacement.	
3-2.23		Replace the XY board as described in the section Board Replacement.	
3-2.23		Replace the crt and make a complete new adjustment of the oscilloscope as described in the Adjustment Procedure.	

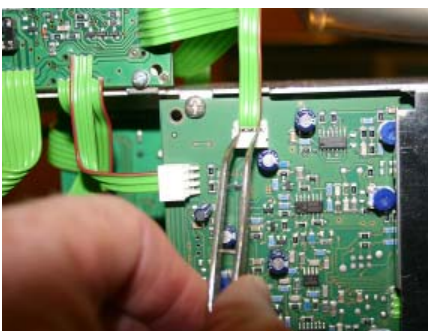

photo 3-2.12



photo 3-2.20.1



photo 3-2.20.2



Item	Behavior of the Instrument	Possible Reason / What to do	Remark
3-3.1	FOCUS setting without effect.	<p>Check the voltage at the FOCUS potentiometer sliding contact (wiper) can be changed between 0 and +12 Volt. This contact is directly accessible on the soldering side of the FC board.</p> <p>If the voltage can be changed between 0 and +12 V, continue with item 3-3.3.</p> <p>If the voltage can not be changed between 0 and +12 V, continue with item 3-3.2</p>	
3-3.2		Replace the FC board as described in section Board Replacement.	
3-3.3		<p>Switch the oscilloscope off, press connector P4004 on TB board and pull the 4 wire ribbon cable (out). Switch the oscilloscope on again.</p> <p>Measure the dc voltage at pin 4 with respect to chassis and turn the FOCUS between left and right stop.</p> <p>If the voltage can be changed between approx. -2 V and +2 V, continue with item 3-3.4.</p> <p>If the voltage can not be changed between approx. -2 V and +2 V, continue with item 3-3.5.</p>	
3-3.4		Replace the CR board as described in section Board Replacement.	
3-3.5		Replace the TB board as described in section Board Replacement.	

Item	Behavior of the Instrument	Possible Reason / What to do	Remark
3-4.1	No X deflection or distorted X deflection in all modes.	Replace the XY board as described in section Board Replacement.	

Item	Behavior of the Instrument	Possible Reason / What to do	Remark
3-5.1	No trace in time base (Yt) mode. Component-Tester and XY mode OK.	Check that all pushbuttons except the POWER pushbutton are released (out).	Normal triggering without trigger signal would have the same effect.
3-5.2		<p>Switch the oscilloscope off.</p> <p>Locate the long ribbon cable connecting the FC with the YP board. Note the instructions of item 4 (FC Board) in the section Board Replacement and remove the plug at connector J2006.</p> <p>Locate the short ribbon cable connecting the FC board with the TB board. Note the instructions of item 5 (FC Board) in the section Board Replacement and remove the plug at connector P4002.</p> <p>Connect the ribbon cables of a spare FC board and connect them with J2006 and P4002. Set all potentiometers to midrange position and release all pushbuttons (out).</p> <p>Switch the oscilloscope on.</p> <ul style="list-style-type: none"> - If trace is visible now, continue with item 3-5.3. - Otherwise continue with item 3-5.4. 	<p>The FC board replacement enables a fast check of the instrument control.</p> <p>As the trace rotation coil is still soldered on the original FC board during this procedure, the trace will be tilted if visible.</p>
3-5.3		Replace the FC board as described in section Board Replacement.	

Item	Behavior of the Instrument	Possible Reason / What to do	Remark
3-5.4		Replace the TB board as described in section Board Replacement. If the trace is not visible, continue with item 3-5.5.	
3-5.5		Replace the XY board as described in section Board Replacement.	

Item	Behavior of the Instrument	Possible Reason / What to do	Remark
3-6.1	No Y deflection or distorted Y deflection in all modes (Yt, XY and Component-Tester).	Replace the XY board as described in section Board Replacement.	

Item	Behavior of the Instrument	Possible Reason / What to do	Remark
3-7.1	One channel not present.	<p>Switch the oscilloscope off.</p> <p>Locate the long ribbon cable connecting the FC with the YP board. Note the instructions of item 4 (FC Board) in the section Board Replacement and remove the plug at connector J2006.</p> <p>Locate the short ribbon cable connecting the FC board with the TB board. Note the instructions of item 5 (FC Board) in the section Board Replacement and remove the plug at connector P4002.</p> <p>Connect the ribbon cables of a spare FC board and connect them with J2006 and P4002. Set all potentiometers to midrange position and release all pushbuttons (out).</p> <p>Switch the oscilloscope on.</p> <ul style="list-style-type: none"> - If the missing channel is now visible, continue with item 3-7.2. - Otherwise continue with item 3-7.3. 	<p>The FC board replacement enables a fast check of the instrument control.</p> <p>As the trace rotation coil is still soldered on the original FC board during this procedure, the trace will be tilted.</p>
3-7.2		Replace the FC board as described in section Board Replacement.	
3-7.3		Replace the YP board as described in section Board Replacement.	

Item	Behavior of the Instrument	Possible Reason / What to do	Remark
3-8.1	No triggering	<p>Switch the oscilloscope off.</p> <p>Locate the long ribbon cable connecting the FC with the YP board. Note the instructions of item 4 (FC Board) in the section Board Replacement and remove the plug at connector J2006.</p> <p>Locate the short ribbon cable connecting the FC board with the TB board. Note the instructions of item 5 (FC Board) in the section Board Replacement and remove the plug at connector P4002.</p> <p>Connect the ribbon cables of a spare FC board and connect them with J2006 and P4002. Set all potentiometers to midrange position and release all pushbuttons (out).</p> <p>Switch the oscilloscope on.</p> <ul style="list-style-type: none"> - If triggering is working now, continue with item 3-8.2. - Otherwise continue with item 3-8.3. 	<p>The FC board replacement enables a fast check of the instrument control.</p> <p>As the trace rotation coil is still soldered on the original FC board during this procedure, the trace will be tilted.</p>

Item	Behavior of the Instrument	Possible Reason / What to do	Remark
3-8.2		Replace the FC board as described in section Board Replacement.	
3-8.3		Replace the YP board as described in section Board Replacement.	

Item	Behavior of the Instrument	Possible Reason / What to do	Remark
3-9.1	Component Tester and/or Calibrator defect	Replace the CC board as described in section Board Replacement. If the error is still present, continue with item 3-9.2	
3-9.2		Replace the XY board as described in section Board Replacement.	

Performance Check HM303-6

Table of Content

- A: Test Instruments required
- B: Basic Settings
- D: Checks
 - 1. Trace Rotation
 - 2. CRT minimum intensity
 - 3. Focus symmetry
 - 4. Astigmatism
 - 5. CH I: Y Accuracy
 - 6. CH II: Y Accuracy
 - 7. CH I: 100 Hz square wave
 - 8. CH II: 100 Hz square wave
 - 9. CH I: Variable Balance
 - 10. CH II: Variable Balance
 - 11. CH I: Y-MAG. x5 Balance
 - 12. CH II: Y-MAG. x5 Balance
 - 13. CH II: INVert Balance
 - 14. ADD Balance
 - 15. CH I: Attenuator
 - 16. CH II: Attenuator
 - 17. Y-Final Amplifier
 - 18. CH I: 5 mV/div Y-Amplifier Bandwidth
 - 19. CH II: 5 mV/div Y-Amplifier Bandwidth
 - 20. CH I: 1 mV/div Y-Amplifier Bandwidth
 - 21. CH II: 1 mV/div Y-Amplifier Bandwidth
 - 22. X-Magnification x1
 - 23. Time Base
 - 24. X-Magnification x10
 - 25. X-Magnification x10 linearity
 - 26. X-Gain in XY-Mode
 - 27. XY mode X-Amplifier Bandwidth
 - 28. Trigger sensitivity
 - 29. CH I: DC-Triggering
 - 30. CH II: DC-Triggering
 - 31. Trigger Bandwidth
 - 32. Extern Trigger Sensitivity
 - 33. Extern Trigger Bandwidth
 - 34. Video Trigger
 - 35. Line Trigger
 - 36. Trigger Filter Check
 - 37. Component-Tester
 - 38. Calibrator Output

A: Test Instruments required

- 1) Fast rise time (<1ns) square wave generator: 10 Hz to 1 MHz (switchable in decades), 25 mV_{pp} output at 50Ω through termination, overshoot less than 1% of signal amplitude (e.g. HZ620).
- 2) Constant amplitude sine wave generator, 20 Hz – 500 MHz, output 5 mV – 5 V into 50Ω preferably with 20dB attenuation (e.g. HM 8134).
- 3) Amplitude Calibrator with 1 kHz square wave output and 600Ω impedance, rise time faster than 1 ns. Output voltage 10 mV_{pp} – 40 V_{pp} in 1 – 2.5 - 5 sequence for 5 divisions display amplitude (e.g. HZ620) with the exception of 40 V_{pp}. Accuracy 0.1% or better.
- 4) Time mark generator from 10 ns/div to 1 s/div. Output min. 10 mV into 50Ω (e.g. HZ620).
- 5) Pre-attenuator 2:1 (1MΩ parallel with 10-25 pF), e.g. HZ20.
- 6) 2 50Ω BNC through termination, e.g. HZ22.
- 7) 2 BNC-cables, 50Ω, e.g. HZ34.
- 8) 50Ω 6 dB splitter with 2 outputs.
- 9) Video signal generator with positive and negative signal output.

B: Basic Settings

Before starting each adjustment procedure, set the oscilloscope to the following basic settings:

- POWER pushbutton pressed (IN position).
- AC/DC input coupling pushbuttons CH I and CH II pressed (IN position).
- All other pushbuttons (Out Position!).
- Rotate the three variable controls (TIME/DIV. and VOLTS/DIV.) to their [calibrated] detent positions.
- Set TIME/DIV. switch to 0.2 ms/div.
- Set both VOLTS/DIV switches to 5 mV/div.
- Rotate the HOLD OFF knob fully counter clockwise.
- Set trigger coupling lever to AC.
- Set all other controls to their midrange positions.

If different settings are required, it is specified in each adjustment.

C: Checks

Do not check the instrument until the normal operating temperature is reached, after a minimum warm up time of 30 minutes.

1. Trace Rotation Check

- Press GD pushbutton CH I (IN position).
- Turn TRACE ROTATION using a small screwdriver to adjust the baseline exactly parallel to a horizontal line of the graticule.
- Set baseline with Y-POS. I knob to the horizontal centre line of the graticule.
- Turn TRACE ROTATION to fully clockwise and counter clockwise position and check the range of inclination of the baseline is at least 1mm at left and right horizontal endpoints of the graticule.
- Turn TRACE ROTATION to adjust baseline to be displayed exactly parallel to the horizontal centre line of the graticule.

2. CRT minimum intensity

- Set INTENS control to fully counter clockwise position.
- Press X-Y pushbutton (IN position).
- Check that the dot has just disappeared.
- Release XY pushbutton.

3. Focus symmetry

- Press X-Y pushbutton (IN position).
- Turn the INTENS knob clockwise until the dot is displayed.
- Turn the FOCUS knob fully clockwise and counter clockwise and check for equal spot size in both (cw and ccw) conditions, so that the focus point is in midrange position.

4. Astigmatism

- Connect a 1MHz square wave signal with 25mV_{pp} at 50Q (HZ22) to input CH I.
- Set time base to 0.1 μs/div.
- Adjust FOCUS control for optimum sharpness.
- Turn FOCUS control a few degrees clockwise and counter clockwise and check that slope and top beam diameter is always sharp (focused).

5. CH I: Y Accuracy

The accuracy reading should always be performed in the following way.

A: Set the square wave bottom on a horizontal graticule line and check the height of the square wave top at the (horizontal) screen centre.

B: Calculate the deviation in respect to the specifications.
A 5% error of 5 div. (50 mm) height means that the acceptance range is from 47.5 mm to 52.5 mm; 3% means ±1.5 mm)

- Check that input coupling CH I is set to DC.
- Check that CH I variable gain knob is set to CAL. position.
- Set time base to 0.5 ms/div.

5.1 CH I 1 mV/div (5% accuracy)

- Set attenuator CH I to 5 mV/div.
- Press Y-MAG x5 pushbutton (IN position).
Note:
5 mV/div in combination with Y-MAG x5 results in 1 mV/div.
- Connect a 5 mV_{pp} (accuracy ±0.1%), 1 kHz square wave signal via 50Q cable to input CH I.

Note:
If HZ620 is used, the minimum voltage is 10 mV without 50Q terminator. As the HZ620 internal resistor is 50Q, connect a 50Q through resistor at the oscilloscope input, to reduce the input voltage to 5 mV_{pp}.

For 0% error the signal height is 5 div.

Note:
If HZ620 is used in combination with a 50Q through terminator, please remove it as it is no longer required in the following checks.

Continue with item 5.2

5.2 CH I 2 mV/div (5% accuracy)

- Set attenuator CH I to 10 mV/div.

Note:
10 mV/div in combination with Y-MAG x5 results in 2 mV/div.

- Connect a 10 mV_{pp} (accuracy ± 0.1%), 1 kHz square wave signal via 50Q cable to input CH I.

- For 0% error the signal height is 5 div.
- Press Y-MAG x5 pushbutton to release it (OUT position).
Continue with item 5.3

5.3 CH I 5 mV/div (3% accuracy)

- Set attenuator CH I to 5 mV/div.
- Connect a 25 mV_{pp} (accuracy ± 0.1%), 1 kHz square wave signal via 50Q cable to input CH I.
- For 0% error the signal height is 5 div.
Continue with item 5.3.1

5.3.1 Variable Gain 2.5:1

- Check that the signal display height is 5 division.
- Turn channel 1 VAR. 2.5:1 knob fully counter clockwise.
- Check that the signal height is less 2 division.
- Turn channel 1 VAR. 2.5:1 knob fully clockwise to its calibrated detent.
Continue with item 5.4.

5.4 CH I 10 mV/div (3% accuracy)

- Set attenuator CH I to 10 mV/div.
- Connect a 50 mV_{pp} (accuracy ± 0.1%), 1 kHz square wave signal via 50Q cable to input CH I.
- For 0% error the signal height is 5 div.
Continue with item 5.5.

5.5 CH I 20 mV/div (3% accuracy)

- Set attenuator CH I to 20 mV/div.
- Connect a 100 mV_{pp} (accuracy ± 0.1%), 1 kHz square wave signal via 50Q cable to input CH I.
- For 0% error the signal height is 5 div.
Continue with item 5.6.

5.6 CH I 50 mV/div (3% accuracy)

- Set attenuator CH I to 50 mV/div.
- Connect a 250 mV_{pp} (accuracy ± 0.1%), 1 kHz square wave signal via 50Q cable to input CH I.
- For 0% error the signal height is 5 div.
Continue with item 5.7.

5.7 CH I 100 mV/div (3% accuracy)

- Set attenuator CH I to 100 mV/div.
- Connect a 500 mV_{pp} (accuracy ± 0.1%), 1 kHz square wave signal via 50Q cable to input CH I.
- For 0% error the signal height is 5 div.
Continue with item 5.8.

5.8 CH I 200 mV/div (3% accuracy)

- Set attenuator CH I to 200 mV/div.
- Connect a 1 V_{pp} (accuracy ± 0.1%), 1 kHz square wave signal via 50Q cable to input CH I.
- For 0% error the signal height is 5 div.
Continue with item 5.9.

5.9 CH I 500 mV/div (3% accuracy)

- Set attenuator CH I to 500 mV/div.
- Connect a 2.5 V_{pp} (accuracy ± 0.1%), 1 kHz square wave signal via 50Q cable to input CH I.
- For 0% error the signal height is 5 div.
Continue with item 5.10.

5.10 CH I 1 V/div (3% accuracy)

- Set attenuator CH I to 1 V/div.
 - Connect a 5 V_{pp} (accuracy ± 0.1%), 1 kHz square wave signal via 50Ω cable to input CH I.
 - For 0% error the signal height is 5 div.
- Continue with item 5.11.

5.11 CH I 2 V/div (3% accuracy)

- Set attenuator CH I to 2 V/div.
 - Connect a 10 V_{pp} (accuracy ± 0.1%), 1 kHz square wave signal via 50Ω cable to input CH I.
 - For 0% error the signal height is 5 div.
- Continue with item 5.12.

5.12 CH I 5 V/div (3% accuracy)

- Set attenuator CH I to 5 V/div.
 - Connect a 25 V_{pp} (accuracy ± 0.1%), 1 kHz square wave signal via 50Ω cable to input CH I.
 - For 0% error the signal height is 5 div.
- Continue with item 5.13.

5.13 CH I 10 V/div (3% accuracy)

- Set attenuator CH I to 10 V/div.
 - Connect a 40 V_{pp} (accuracy ± 0.1%), 1 kHz square wave signal via 50Ω cable to input CH I.
 - For 0% error the signal height is 4 div. (3% = 1.2 mm).
- Continue with item 5.14.

5.14 CH I 20 V/div (3% accuracy)

- Set attenuator CH I to 20 V/div.
- Connect a 40 V_{pp} (accuracy ± 0.1%), 1 kHz square wave signal via 50Ω cable to input CH I.
- For 0% error the signal height is 2 div. (3% = 0.6 mm).

6. CH II: Y Accuracy

The accuracy reading should always be performed in the following way.

- A: Set the square wave bottom on a horizontal graticule line and check the height of the square wave top at the (horizontal) screen centre.
- B: Calculate the deviation in respect to the specifications. A 5% error of 5 div. (50 mm) height means that the acceptance range is from 47.5 mm to 52.5 mm; 3% means ±1.5 mm)
- Check that input coupling CH II is set to DC.
 - Check that CH II variable gain knob is set to CAL. position.
 - Set time base to 0.5 ms/div.
 - Press CH I/II pushbutton (IN position) to select channel II.

6.1 CH II 1 mV/div (5% accuracy)

- Set attenuator CH II to 5 mV/div.
- Press Y-MAG x5 pushbutton (IN position).

Note:

5 mV/div in combination with Y-MAG x5 results in 1 mV/div.

- Connect a 5 mV_{pp} (accuracy ± 0.1%), 1 kHz square wave signal via 50Ω cable to input CH II.

Note:

If HZ620 is used, the minimum voltage is 10 mV without 50Ω terminator. As the HZ620 internal resistor is 50 Ω, connect a 50Ω through resistor at the oscilloscope input, to reduce the input voltage to 5 mV_{pp}.

- For 0% error the signal height is 5 div.

Note:

If HZ620 is used in combination with a 50Ω through terminator, please remove it as it is no longer required in the following checks.

Continue with item 6.2.

6.2 CH II 2 mV/div (5% accuracy)

- Set attenuator CH II to 10 mV/div.

Note:

10 mV/div in combination with Y-MAG x5 results in 2 mV/div.

- Connect a 10 mV_{pp} (accuracy ± 0.1%), 1 kHz square wave signal via 50Ω cable to input CH II.
 - For 0% error the signal height is 5 div.
 - Press Y-MAG x5 pushbutton to release it (OUT position).
- Continue with item 6.3.

6.3 CH II 5 mV/div (3% accuracy)

- Set attenuator CH II to 5 mV/div.
 - Connect a 25 mV_{pp} (accuracy ± 0.1%), 1 kHz square wave signal via 50Ω cable to input CH II.
 - For 0% error the signal height is 5 div.
- Continue with item 6.3.1

6.3.1 Variable Gain 2.5:1

- Check that the signal display height is 5 division.
- Turn channel 2 VAR. 2.5:1 knob fully counter clockwise.
- Check that the signal height is less 2 division.
- Turn channel 2 VAR. 2.5:1 knob fully clockwise to its calibrated detent.

Continue with item 6.4.

6.4 CH II 10 mV/div (3% accuracy)

- Set attenuator CH II to 10 mV/div.
 - Connect a 50 mV_{pp} (accuracy ± 0.1%), 1 kHz square wave signal via 50Ω cable to input CH II.
 - For 0% error the signal height is 5 div.
- Continue with item 6.5.

6.5 CH II 20 mV/div (3% accuracy)

- Set attenuator CH II to 20 mV/div.
 - Connect a 100 mV_{pp} (accuracy ± 0.1%), 1 kHz square wave signal via 50Ω cable to input CH II.
 - For 0% error the signal height is 5 div.
- Continue with item 6.6.

6.6 CH II 50 mV/div (3% accuracy)

- Set attenuator CH II to 50 mV/div.
 - Connect a 250 mV_{pp} (accuracy ± 0.1%), 1 kHz square wave signal via 50Ω cable to input CH II.
 - For 0% error the signal height is 5 div.
- Continue with item 6.7.

6.7 CH II 100 mV/div (3% accuracy)

- Set attenuator CH II to 100 mV/div.
- Connect a 500 mV_{pp} (accuracy ± 0.1%), 1 kHz square wave signal via 50Ω cable to input CH II.
- For 0% error the signal height is 5 div.

Continue with item 6.8.

6.8 CH II 200 mV/div (3% accuracy)

- Set attenuator CH II to 200 mV/div.
- Connect a 1 V_{pp} (accuracy ± 0.1%), 1 kHz square wave signal via 50Ω cable to input CH II.
- For 0% error the signal height is 5 div.

Continue with item 6.9.

6.9 CH II 500 mV/div (3% accuracy)

- Set attenuator CH II to 500 mV/div.
- Connect a 2.5 V_{pp} (accuracy ± 0.1%), 1 kHz square wave signal via 50Ω cable to input CH II.
- For 0% error the signal height is 5 div.

Continue with item 6.10.

6.10 CH II 1 V/div (3% accuracy)

- Set attenuator CH II to 1 V/div.
- Connect a 5 V_{pp} (accuracy ± 0.1%), 1 kHz square wave signal via 50Ω cable to input CH II.
- For 0% error the signal height is 5 div.

Continue with item 6.11.

6.11 CH II 2 V/div (3% accuracy)

- Set attenuator CH II to 2 V/div.
- Connect a 10 V_{pp} (accuracy ± 0.1%), 1 kHz square wave signal via 50Ω cable to input CH II.
- For 0% error the signal height is 5 div.

Continue with item 6.12.

6.12 CH II 5 V/div (3% accuracy)

- Set attenuator CH II to 5 V/div.
- Connect a 25 V_{pp} (accuracy ± 0.1%), 1 kHz square wave signal via 50Ω cable to input CH II.
- For 0% error the signal height is 5 div.

Continue with item 6.13.

6.13 CH II 10 V/div (3% accuracy)

- Set attenuator CH II to 10 V/div.
- Connect a 40 V_{pp} (accuracy ± 0.1%), 1 kHz square wave signal via 50Ω cable to input CH II.
- For 0% error the signal height is 4 div. (3% = 1.2 mm).

Continue with item 6.14.

6.14 CH II 20 V/div (3% accuracy)

- Set attenuator CH II to 20 V/div.
- Connect a 40 V_{pp} (accuracy ± 0.1%), 1 kHz square wave signal via 50Ω cable to input CH II.
- For 0% error the signal height is 2 div. (3% = 0.6 mm).

7. CH I: 100 Hz square wave

- Check that input coupling CH I is set to DC.
- Check that CH I variable gain knob is set to CAL. position.
- Set time base to 2 ms/div.
- Check that input attenuator CH I is set to 5 mV/div.
- Check that the square wave signal is displayed with a flat top.

8. CH II: 100 Hz square wave

- Press CH I/II pushbutton (IN position) to select channel II.
- Check that input coupling CH II is set to DC.
- Check that CH II variable gain knob is set to CAL. position.
- Set time base to 2 ms/div.
- Check that input attenuator CH II is set to 5 mV/div.
- Check that the square wave signal is displayed with a flat top.

9. CH I: Variable Balance

- Rotate variable gain knob of channel I continuously fully counter clockwise (left stop) and clockwise (right stop) and check that the trace does not move more than 2 mm (0.2 div) in vertical direction.

10. CH II: Variable Balance

- Press CH I/II pushbutton (IN position) to select channel II.
- Rotate variable gain knob of channel II continuously fully counter clockwise (left stop) and clockwise (right stop) and check that the trace does not move more than 2 mm (0.2 div) in vertical direction.

11. CH I: Y-MAG. x5 Balance

- Press and release the CH I Y MAG x5 pushbutton and check that the trace does not move more than 2 mm (0.2 div) in vertical direction.

12. CH II: Y-MAG. x5 Balance

- Press CH I/II pushbutton (IN position) to select channel II.
- Press and release the CH II Y MAG x5 pushbutton and check that the trace does not move more than 2 mm (0.2 div) in vertical direction.

13. CH II: INVERT Balance

- Press CH I/II pushbutton (IN position) to select channel II.
- Press and release the INV. pushbutton and check that the trace does not move more than 2 mm (0.2 div) in vertical direction.

14. ADD Balance

- Press DUAL pushbutton.
- Set both traces exactly on the horizontal centre line and do not change the setting until this check has been finished.
- Release DUAL pushbutton (OUT position).
- Press and release the ADD pushbutton (IN position) and check that the trace does not move more than 2 mm (0.2 div) in vertical direction.

15. CH I: Attenuator

15.1 CH I Input Capacitance Adaptation

- Connect a 50 mV_{pp}, 1 kHz square wave signal via a 2:1 pre-attenuator (1MΩ with parallel C-trimmer) to input CH I.
- Check that DC input coupling is selected.
- Check that attenuator is set to 5 mV/div.
- Check that time base is set to 0.2 ms/div.
- Check for 5 divisions signal height at 5 mV/div. attenuator setting.
- Adjust C-trimmer in 2:1 pre-attenuator for leading edge without over- or undershoot and flat square wave top.
- Do not change the C-trimmer settings until item 15 is finished.

15.1 CH I: 2:1 Attenuator

- Set attenuator CH I to 10 mV/div.
- Increase the calibrator output voltage for 5 division signal height.
- Check for leading edge without over- or undershoot and flat square wave top.

15.2 CH I: 4:1 Attenuator

- Set attenuator CH I to 20 mV/div.
- Increase the calibrator output voltage for 5 division signal height.
- Check for leading edge without over- or undershoot and flat square wave top.

15.3 CH I: 10:1 Attenuator

- Set attenuator CH I to 50 mV/div.
- Increase the calibrator output voltage for 5 division signal height.
- Check for leading edge without over- or undershoot and flat square wave top.

15.4 CH I: 100:1 Attenuator

- Set attenuator CH I to 0.5 V/div.
- Increase the calibrator output voltage for 5 division signal height.
- Check for leading edge without over- or undershoot and flat square wave top.

15.5 CH I: 10:1 in combination with 100:1 Attenuator

- Set attenuator CH I to 5 V/div.
- Increase the calibrator output voltage for 5 division signal height.
- Check for leading edge without over- or undershoot and flat square wave top.

16. CH II: Attenuator**16.1 CH II Input Capacitance Adaptation**

- Press CH I/II pushbutton (IN position) to select channel II.
- Connect a 50 mV_{pp}, 1 kHz square wave signal via a 2:1 pre-attenuator (1M Ω with parallel C-trimmer) to input CH II.
- Check that DC input coupling is selected.
- Check that attenuator is set to 5 mV/div.
- Check that time base is set to 0.2 ms/div.
- Check for 5 divisions signal height at 5 mV/div. attenuator setting.
- Adjust C-trimmer in 2:1 pre-attenuator for leading edge without over- or undershoot and flat square wave top.
- Do not change the C-trimmer settings until item 15 is finished.

16.1 CH II: 2:1 Attenuator

- Set attenuator CH II to 10 mV/div.
- Increase the calibrator output voltage for 5 division signal height.
- Check for leading edge without over- or undershoot and flat square wave top.

16.2 CH II: 4:1 Attenuator

- Set attenuator CH II to 20 mV/div.
- Increase the calibrator output voltage for 5 division signal height.
- Check for leading edge without over- or undershoot and flat square wave top.

16.3 CH II: 10:1 Attenuator

- Set attenuator CH II to 50 mV/div.
- Increase the calibrator output voltage for 5 division signal height.
- Check for leading edge without over- or undershoot and flat square wave top.

16.4 CH II: 100:1 Attenuator

- Set attenuator CH II to 0.5 V/div.
- Increase the calibrator output voltage for 5 division signal height.
- Check for leading edge without over- or undershoot and flat square wave top.

16.5 CH II: 10:1 in combination with 100:1 Attenuator

- Set attenuator CH II to 5 V/div.
- Increase the calibrator output voltage for 5 division signal height.
- Check for leading edge without over- or undershoot and flat square wave top.

17. Y-Final Amplifier

- Connect a 25 mV_{pp}, 1 MHz square wave signal via a 50 Ω cable and a 50 Ω through-termination to input CH I.
- Check that CH I input coupling is set to DC.
- Set time base to 0.1 μ s/div.
- Check for fast leading edge without over- or undershoot and flat square wave top.
- Press CH I/II pushbutton (IN position).
- Connect the 25 mV_{pp}, 1 MHz square wave signal via a 50 Ω cable and a 50 Ω through-termination to input CH II.
- Check that CH II input coupling is set to DC.
- Check for fast leading edge without over- or undershoot and flat square wave top.

18. CH I: 5 mV/div Y-Amplifier Bandwidth

- Connect a 40 mV_{pp}/50 kHz sine wave signal from a Constant Amplitude Generator via a 50 Ω through-termination to the input of CH I.
- Adjust the generator amplitude for 8 div. display height on the screen.
- Increase the generator frequency until the signal is displayed with 5.6 div. height (-3dB) and check that the generator frequency is higher than 35 MHz.

19. CH II: 5 mV/div Y-Amplifier Bandwidth

- Press CH I/II pushbutton (IN position).
- Connect a 8 mV_{pp}/50 kHz sine wave signal from a Constant Amplitude Generator via a 50 Ω through-termination to the input of CH II.
- Adjust the generator amplitude for 8 div. display height on the screen.
- Increase the generator frequency until the signal is displayed with 5.6 div. height (-3dB) and check that the generator frequency is higher than 35 MHz.

20. CH I: 1 mV/div Y-Amplifier Bandwidth

- Connect a 8 mV_{pp} / 50 kHz sine wave signal from a Constant Amplitude Generator via a 50Ω through-termination to the input of CH I.
- Adjust the generator amplitude for 8 div. display height on the screen.
- Increase the generator frequency until the signal is displayed with 5.6 div. height (-3dB) and check that the generator frequency is higher than 10 MHz.

21. CH II: 1 mV/div Y-Amplifier Bandwidth

- Press CH I/II pushbutton (IN position).
- Connect a 8 mV_{pp} / 50 kHz sine wave signal from a Constant Amplitude Generator via a 50Ω through-termination to the input of CH II.
- Adjust the generator amplitude for 8 div. display height on the screen.
- Increase the generator frequency until the signal is displayed with 5.6 div. height (-3dB) and check that the generator frequency is higher than 10 MHz.

22. X-Magnification x1

- Check for 10.2div. trace length in the following way:
- Connect a square wave signal of approx. 25 mV_{pp} and approx. 1 kHz to input CH I.
- Check that DC input coupling is selected.
- Check that attenuator is set to 5 mV/div.
- Check that time base is set to 1 ms/div.
- Check that the trace is at least 10 division long.
- Set trace start to the leftmost vertical graticule line.
- Set the signal generator frequency in such a way that a signal period is exactly 1 division on the X axis.
- Turn X-POS. knob to the left to move the signal exactly 1 division to the left.
- Now that part of the trace – previously outside the graticule – can be measured.

23. Time Base

Note:

This check assumes that the trace length (item 22. X-Magnification x1) has been checked before.

Accuracy reading:

The accuracy reading should always be performed in the following way:

- A: Set Y-POS. I knob on the front panel for reading of the pulse peak or sine wave zero crossing at the horizontal center line of the graticule.
- B: Move trace with X-POS. knob (front panel) so that the first pulse peak or sine wave zero crossing coincides with the first or second vertical graticule line at the left side of the graticule.
- C: Check that 1 pulse or signal period per division is displayed and the rightmost pulse peak or zero crossing coincides with the vertical graticule line as on the left side = 0% error.
- D: The maximum acceptable deviation at the 10th or 11th pulse or zero crossing is ±3 mm (3%).

Test procedure:

- Check that X MAG x10 pushbutton is released (OUT position).
- Set TIME/DIV. knob to 0.1 μs.
- Connect a 0.1 μs time mark signal or a 10 MHz sine wave signal (accuracy 0.1 ppm or better) to the input of CH I.

- Turn CH I VOLTS/DIV knob for a signal height of approximately 5 divisions.
- Set LEVEL knob on the front panel for stable triggering.
- Check the accuracy at this setting.
- Turn TIME/DIV knob one step counter clockwise (0.2 μs) and similarly change the time mark generator signal (0.2 μs spike or 5 MHz sine wave).
- Repeat this procedure until the 0.2 s time base setting has been checked.

23.1 VAR. 2.5:1

- Set TIME/DIV. knob to 0.2 ms.
- Connect a 0.2 ms time mark signal or a 5 kHz sine wave signal (accuracy 0.1 ppm or better) to the input of CH I.
- Check that 1 pulse or signal period per division is displayed.
- Turn time base VAR. 2.5:1 knob fully counter clockwise.
- Check that at least 2.5 pulses or signal periods are displayed.
- Turn time base VAR. 2.5:1 knob fully clockwise to its calibrated detent.

24. X-Magnification x10

Note:

This check assumes that the trace length (item 22. X-Magnification x1) and the time base (item 23) has been checked before.

Accuracy reading:

The accuracy reading should always be performed in the following way:

- A: Set Y-POS. I knob on the front panel for reading of the pulse peak or sine wave zero crossing at the horizontal center line of the graticule.
- B: Move trace with X-POS. knob (front panel) so that the first pulse peak or sine wave zero crossing coincides with the first or second vertical graticule line at the left side of the graticule.
- C: Check that 1 pulse or signal period per division is displayed and the rightmost pulse peak or zero crossing coincides with the vertical graticule line as on the left side = 0% error.
- D: The maximum acceptable deviation at the 10th or 11th pulse or zero crossing is ±5 mm (5%).

Test procedure:

- Press X MAG x10 pushbutton (IN position).
- Set TIME/DIV. knob to 0.1 μs.
- Connect a 0.01 μs time mark signal or a 100 MHz sine wave signal (accuracy 0.1 ppm or better) to the input of CH I.
- Turn CH I VOLTS/DIV knob for a suitable signal height for a precise reading; in case the 100 MHz signal the possible signal height is limited by the measuring amplifier frequency response.
- Set LEVEL knob on the front panel for stable triggering.
- Check the accuracy at this setting.
- Turn TIME/DIV knob one step counter clockwise (0.2 μs) and similarly change the time mark generator (0.2 μs spike or 5 MHz sine wave).
- Repeat this procedure until the 0.2 s time base setting has been checked with a 0.02 s time mark signal or a 50 Hz sine wave signal.

25. X-Magnification x10 linearity

- Set time base to 0.5 $\mu\text{s}/\text{div}$.
- Press MAG x10 pushbutton (IN position).
- Connect a 10 mV, 35 MHz sine wave signal via a 50 Ω cable and a 50 Ω through-terminator to input channel I.
- Check that the sine wave signal is displayed with a height of approx. 3–4 div.
- Set Y-POS. I knob so that the signal is displayed at the screen centre.
- Turn X-POS. knob and watch if the sine wave signal is compressed and expanded when being moved (accordion effect).

26. X-Gain in XY-Mode

- Connect a 25 mV_{pp} / 1 kHz square wave signal via a 50 Ω cable and a 50 Ω through-terminator to input channel I.
- Check that input attenuator CH I is set to 5 mV/div.
- Check that variable gain knob is in its CAL. detent.
- Set input coupling to DC.
- Press X-Y pushbutton (IN position).
- Turn X-POS. knob to move both displayed dots symmetrically about the screen centre.
- Check for 5 division dot spacing.

27. XY mode X -Amplifier Bandwidth

- Press XY pushbutton (IN position).
- Connect a 8 mV_{pp} / 50 kHz sine wave signal from a Constant Amplitude -Generator via a 50 Ω through-termination to the input of CH I.
- Adjust the generator amplitude for 8 div. X deflection symmetrically about the screen centre.
- Increase the generator frequency until the signal is displayed with 5.6 div. length (-3dB) and check that the generator frequency is higher than 2.5 MHz.

28. Trigger sensitivity

- Connect a 25mV_{pp}, 50 kHz sine wave signal to input CH I.
- Check that attenuator CH I is set to 5 mV/div.
- Set input coupling CH I to AC.
- Set time base to 50 $\mu\text{s}/\text{div}$.
- Set trigger coupling to AC.
- Check that the AT/NM pushbutton is in AT (automatic trigger) position (pushbutton switch OUT).
- Set LEVEL control to centre position.
- Reduce signal height to 0.5 div by switching the attenuator to 50 mV/div.
- Reduce signal height carefully by turning the variable gain knob to the left (ccw) and check that triggering is performed with a signal height less than .5 division in both SLOPE pushbutton settings.

29. CH I: DC-Triggering

- Connect a 50 kHz sine wave signal to input CH I.
- Set time base to 5 $\mu\text{s}/\text{div}$.
- Set generator amplitude for a display height of 8 divisions.
- Check that input coupling CH I is set to AC.
- Check that trigger coupling is set to AC.
- Press AT/NM (Automatic/Norm) pushbutton (IN position).
- Set LEVEL knob for a trigger point at the centre of the signal
- Slope and note the position (reference).
- Set trigger coupling to DC and check that the trigger point (trace start) is in the same position (reference) as under AC coupling condition.

30. CH II: DC-Triggering

- Press CH I/II pushbutton (IN position) to select channel II.
- Connect a 50 kHz sine wave signal to input CH II.
- Set time base to 5 $\mu\text{s}/\text{div}$.
- Set generator amplitude for a display height of 8 divisions.
- Check that input coupling CH II is set to AC.
- Check that trigger coupling is set to AC.
- Press AT/NM (Automatic/Norm) pushbutton (IN position).
- Set LEVEL knob for a trigger point at the centre of the signal
- Slope and note the position (reference).
- Set trigger coupling to DC and check that the trigger point (trace start) is in the same position (reference) as under AC coupling condition.

31. Trigger Bandwidth

- Set time base to 0.1 $\mu\text{s}/\text{div}$.
- Press X-MAG. x10 pushbutton (IN position).
- Set input coupling switch CH I to DC.
- Set trigger coupling to AC.
- Check that AT/NM (Automatic/Norm) pushbutton is released (OUT position).
- Turn LEVEL knob to midrange position.
- Set input attenuator CH I to 5 mV/div.
- Connect a 50 MHz sine wave signal to input CH I.
- Set generator amplitude for a display height of 0.5 divisions.
- Check that triggering is performed.
- Set sine wave generator to 100 MHz.
- Set generator amplitude for a display height of 0.8 divisions.
- Check that triggering is performed.

32. Extern Trigger Sensitivity

- Connect a 600 mV_{pp}, 50 kHz sine wave signal from a constant amplitude generator via a 2:1 signal splitter and via 50 Ω through terminators to the inputs of CH I and TRIG. EXT.
- Check that attenuator CH I is set to 200 mV/div.
- Check that the signal is displayed with 3 div. height on the screen.
- Press TRIG. EXT. pushbutton (IN position).
- Check that the signal can trigger the time base in AT (automatic) and NM (normal) trigger mode in combination with AC- and DC-trigger coupling.
- Continue with item 33 without changing the signal parameters.

33. Extern Trigger Bandwidth

- Operate oscilloscope as described under item 32.
- Set the generator frequency to 50 MHz.
- Set attenuator CH I (VOLTS/DIV) for approx. 2 to 6 div. signal display height.
- Check that the signal can trigger the time base in AT (automatic) and NM (normal) trigger mode in combination with AC and DC trigger coupling.

34. Video Trigger

- Check that CH I input coupling switch is set to DC.
- Connect video signal with positive sync. pulses to input CH I.
- Set input attenuator CH I for 0.5 div display amplitude of the sync. pulses.
- Set trigger coupling switch to TV.
- Set time base to 5 ms/div for TV field triggering.

- Check that trigger starts with field sync. pulses; approx. 2.5 frames should be visible.
- Change polarity of the video signal.
- Press SLOPE pushbutton (IN position).
- Again approx. 2.5 frames should be displayed triggered.
- Set time base to 20 $\mu\text{s}/\text{div}$ for TV line triggering.
- Now approx. 3 lines should be visible.
- Change polarity of video signal.
- Release SLOPE pushbutton to the OUT position.
- Again 3 lines should be displayed triggered.

Note:

The switch over from frame to line TV triggering is performed by the time base switch. In time base settings from 0.2 s/div to 0.2 ms/div TV frame triggering is selected. Line triggering is present from 0.1 ms/div to 0.1 $\mu\text{s}/\text{div}$.

35. Line Trigger

- Set time base to 5 ms/div.
- Connect 10:1 probe to CH I input.
- Place the probe tip close to the oscilloscope mains cable, so that it can pick up the more or less distorted line/mains signal.
- Change attenuator CH I setting for a suitable display height of at least 1 div.
- Press AT/NM and ALT pushbuttons (IN position).

Note:

This combination is marked with a sine symbol indicating line/mains triggering.

- Check that the Trigger-LED (TR) is ON and the line/mains signal is stable triggered.
- Disconnect 10:1 probe from CH I input.
- Check that the Trigger-LED (TR) is still ON although no signal is applied.
- Release AT/NM and ALT pushbuttons (OUT position).
- Check that the Trigger-LED (TR) is OFF.

36. Trigger Filter Check

- Set time base to 1 ms/div.
- Connect a 1 kHz sine wave signal, 40 mV_{pp} amplitude, to input CH I and check for full screen deflection (80 mm at 5 mV/div).
- Set input attenuator CH I to 50 mV/div and check for 8 mm display height.
- Set trigger coupling to AC, DC and LF. The signal must always trigger.
- Set time base to 50 $\mu\text{s}/\text{div}$.
- Set sine wave generator to 50 kHz and 40 mV_{pp} output amplitude and check for 8mm display height.
- Set trigger coupling to AC and DC. The signal must always trigger.
- Select LF trigger coupling. Now the signal should not trigger.

37. Component-Tester

- Press Comp. Tester pushbutton (IN position).
- Check that a horizontal trace of approximately 8 div. length is displayed.
- Connect a short piece of wire between both "COMP. TESTER" sockets.
- Check that the trace is displayed in vertical direction with approximately 6 div. height.

38. Calibrator Output

- Connect 10:1 probe to CH I input.
- Check that attenuator CH I is set to 5 mV/div.
- Insert the probe tip into the 0.2 V_{pp} calibrator signal output socket.
- Check that the 1 kHz / 1 MHz pushbutton is released (OUT position).
- Set time base to 0.2 ms/div.
- Check that approximately 2 signal periods are visible.
- Press 1 kHz / 1 MHz pushbutton (IN position).
- Set time base to 0.2 $\mu\text{s}/\text{div}$.
- Check that once again approximately 2 signal periods are visible.

Spare-Part List HM303-6

Spare Part	Spare Part Number
CRT Board	29-1000-0004
CRT Modul (Tube)	29-1000-0008
FC Board	29-1000-0001
TB Board	29-1000-0007
PS Board	29-1000-0002
AT Board	29-1000-0003
CC Board	29-1000-0005
XY Board	29-1000-0006
Front Cover	29-1000-0011
Rear Cover	29-1000-0010
Casing with Handle	29-1000-0009
Knob Set	29-1000-0013
Screenfilterpane	29-1000-0012

Adjustment Procedure HM303-6

WARNING

The Instrument must be disconnected from the mains power supply whenever you open the case, repair or exchange parts.

For measurement and adjustment purposes or whenever the instrument is operated with removed case, the instrument must be operated via an isolation transformer (Safety Class II).

HIGH VOLTAGE WARNING!

Hazardous High Voltage of up to –2000 Volts is present inside this Instrument. The areas particularly affected by High Voltage are the high voltage circuit on the PS board and the CT-board.

Mains (line) voltage is present at all parts and ground connections at the primary side of the switch mode power supply.

SERVICE AND ADJUSTMENT

- of this instrument should only be performed in accordance and in conjunction with the operating manual and the WARNINGS contained therein, particularly Section "General information" page 6 and 7.
- should only be performed by suitable qualified and experienced service personnel, or should be referred to one of the HAMEG companies listed on the rear cover of the manual.

Test Instruments required:

- 1) Hameg Test Generator HZ620
 or alternatively: Scope Tester HZ 60,
 Amplitude Calibrator with 1 kHz square wave output, 600 Ω impedance, rise time faster than 150 ns. Output voltage 2 mV – 20 Volts in 1-2-5 sequence for 4 divisions of display amplitude and Time Mark Generator from 0.1 μs/div to 0.5 s/div. Output min. 10 mV into 50 Ω.
- 2) Programmable Synthesizer HM813x
 or alternatively
 Constant Amplitude Sine Wave Generator, 20 Hz – 250 MHz, output 5 mV_{pp} – 5 V_{pp} into 50 Ωs (e.g. HM 813x, TEK SG502 + TEK SG503).
- 3) Pre-attenuator 2:1 (1 MΩ || 12-48 pF), e.g. HZ 23.
- 4) 50 Ω BNC through-Termination, e.g. HZ22.
- 5) 2 BNC-cables, 50 Ωs, e.g. HZ34.
- 6) BNC T-Connector.
- 7) Oscilloscope Probe 10:1, with exactly 9 MΩ series resistance and compensated for test-oscilloscope mentioned under 8).
- 8) Oscilloscope 100 MHz, 5 mV/div to 5 V/div, e.g. HM 1000.
- 9) Trimming/adjusting tool.
- 10) Variable output safety Isolation Transformer (Safety Class II).
- 11) Video Signal Generator with positive and negative signal output.
- 12) Metal sheet for cabinet capacity simulation during Y final amplifier adjustment.
- 13) Digital Multimeter, e.g. HM8011.

This procedure covers all adjustments and the most important – but not all – performance checks. The correct sequence of all adjustment steps must be strictly followed.

Exact adjustment is only possible when any influence of the Earth`s magnetic field has been compensated for with the trimmer marked TR (trace rotation) on the front panel.

All adjustments should only be performed by qualified and experienced personnel. This is particularly important for adjustments in the high voltage section of the instrument.

Table of Contents

- 1) RV1001: Adjustment of +146 Volt supply
- 2) +175 Volt check
- 3) RV1003: Adjustment of +12 Volt supply
- 4) -6 Volt accuracy check
- 5) Y plate voltage check
- 6) R6013: CRT minimum intensity
- 7) RV1005: Focus symmetry
- 8) R6024: Astigmatism correction
- 9) RV4002: Focus control
- 10) P2007: Y-Gain CH I at 5 mV/div
- 11) P2002: Y-Gain CH I at 2 mV/div
- 12) P2003: Channel I Y-MAG. x5 balance
- 13) P2001: 100 Hz square wave CH I
- 14) P2005: Variable balance CH I
- 15) C2011/C2007: 10:1 Attenuator compensation CH I
- 16) C2009/C2010: 100:1 Attenuator compensation CH I
- 17) P2011: Y-Gain CH II at 5 mV/div
- 18) P2015: Y-Gain CH II at 2 mV/div
- 19) P2016: Channel II Y-MAG. x5 balance
- 20) P2014: 100 Hz square wave CH II
- 21) P2010: Variable balance CH II
- 22) P2009: Invert balance CH II
- 23) C2110/C2107: 10:1 Attenuator compensation CH II
- 24) C2108/C2103: 100:1 Attenuator compensation CH II
- 25) P2012: ADDition balance
- 26) RV4005: Sawtooth start position
- 27) RV9004: X-Magnification x1
- 28) CV4001: 0.5 μ s/div time base adjustment
- 29) RV4004: 50 μ s/div time base adjustment
- 30) RV4003: 50 ms/div time base adjustment
- 31) RV9003: X-Magnification x10
- 32) C9026, C9027: X-Magnification x10 linearity
- 33) RV9002: X-Gain Adjustment in XY-Mode
- 34) RV4001: Trigger-Symmetry
- 35) P2006: DC-Trigging CH I
- 36) P2008: DC-Trigging CH II
- 37) CV9001/9002, RV9006/9005: Y-Final Amplifier
- 38) Y-Amplifier Bandwidth Check
- 39) RV9001: Component-Tester Y-Offset
- 40) VR7003: Trace Rotation check
- 41) RV4501: Component-Tester trace inclination
- 42) RV4502: Calibrator Output
- 43) XY mode: X-Amplifier Bandwidth Check
- 44) Trigger Filter Check
- 45) Trigger Bandwidth Check
- 46) External Trigger Check
- 47) Video Trigger Check
- 48) Invert-Balance Check CH II
- 49) Variable-Balance Check CH I
- 50) Variable-Balance Check CH II

NOTE

The adjustment procedures assume that the instrument had once been properly adjusted in the factory and adjustments are required due to component aging or the replacement of defective components.

Before starting each adjustment procedure, set the oscilloscope to the following basic settings:

- POWER pushbutton pressed (IN position).
- All other pushbuttons (Out Position!).
- Rotate the three variable controls (TIME/DIV. and VOLTS/DIV.) to their (calibrated) detent positions.
- Set TIME/DIV. switch to 0.2 ms/div.
- Set both VOLTS/DIV switches to 5 mV/div.
- Rotate the HOLD OFF knob fully counter clockwise.
- Set trigger coupling lever to AC.
- Set all other controls to their midrange positions.

If different settings are required, it is specified in each adjustment.

1 RV1001: Adjustment of +146 Volt supply

- Remove power supply cover.
- Locate and identify RV1001 on PS-Board.
- Locate and identify check point socket M9001 on XY-Board.
- Locate and identify pin 2 at socket M9001.
- Adjust RV1001 for exactly +146 Volt (± 0.5 V) measured at pin 2 with respect to ground (chassis).
- Replace power supply cover.

PS-Board 1



RV1001

2 +175 Volt check

- Locate and identify check point socket M9001 on XY-Board.
- Locate and identify pin 1 at socket M9001.
- Check that approx. +175 Volt can be measured at pin 1 with respect to ground (chassis).

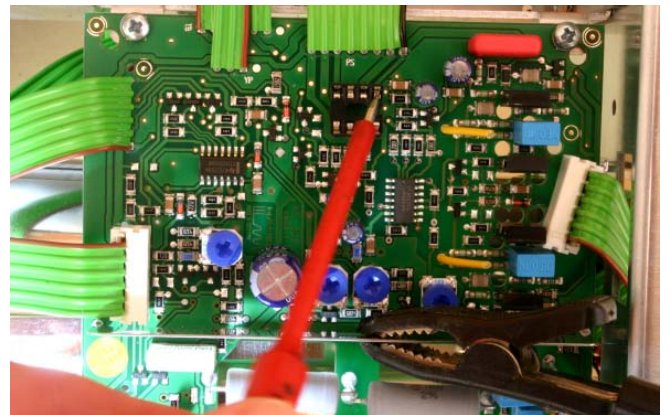

3 RV1003: Adjustment of +12 Volt supply

- Locate and identify RV1003 on PS-Board.
- Locate and identify check point socket M9001 on XY-Board.
- Locate and identify pin 4 at socket M9001.
- Adjust RV1003 for exactly +12 Volt (± 50 mV) measured at pin 4 with respect to ground (chassis).

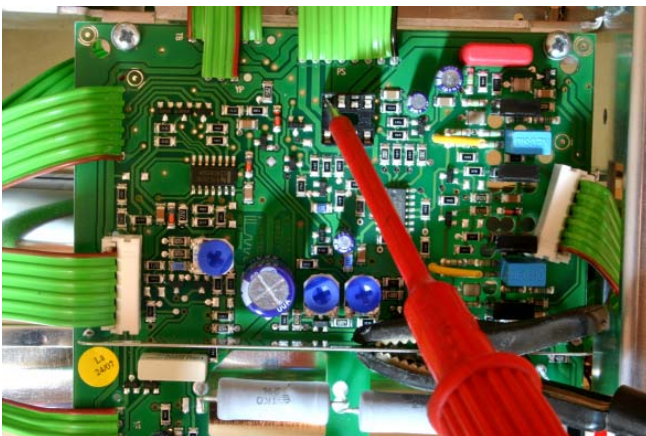

PS-Board 2

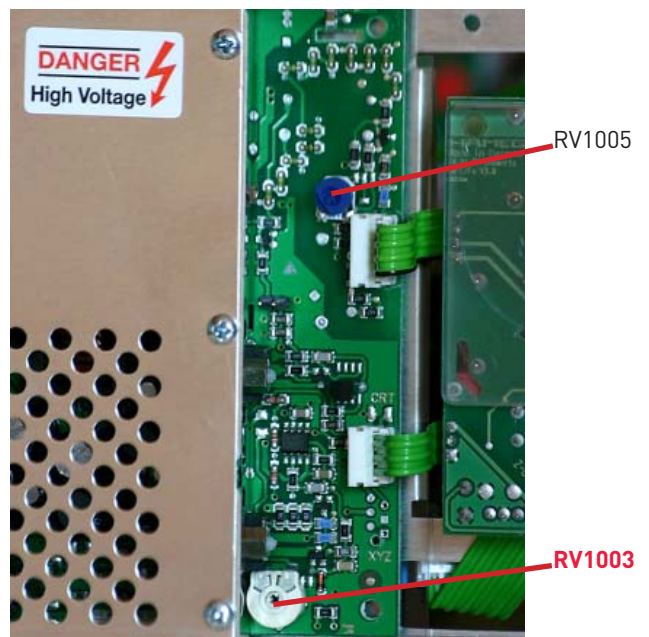

4 -6 Volt accuracy check

- Locate and identify check point socket.
- Locate and identify check point socket M9001 on XY-Board.
- Locate and identify pin 6 at socket M9001.
- Check that -6 Volt (± 50 mV) can be measured at pin 6 with respect to ground (chassis).



5 Y plate voltage check

- Switch the instrument OFF.
- Locate and identify the Y final stage transistors T9017 and T9024 mounted at the rear chassis.
- Connect both collectors together (connected with the Y plates) by a wire (short). The collectors are the centre leads of the transistors.
- Switch the instrument ON.
- Check that +85 Volt (± 2 V) can be measured at the collectors with respect to ground (chassis).
- Switch the instrument OFF.
- Remove the short between the Y final stage collectors (Y plates).
- Switch the instrument ON.

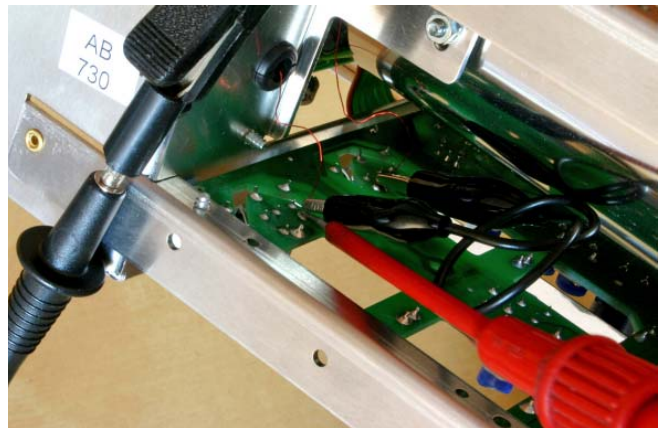

6 R6013: CRT minimum intensity

- Locate and identify R6013 CR-Board.
- Set INTENS. control to fully left position.
- Press X-Y pushbutton (IN position).
- Adjust R6013 so that the dot just disappears.
- Release XY pushbutton.

CR-Board



R6013

RV6024

7 RV1005: Focus symmetry

- Locate and identify RV1005 on PS-Board.
- Press X-Y pushbutton (IN position).
- Turn the INTENS knob clockwise until the dot is displayed.
- Turn the INTENS knob fully clockwise and counter clockwise and adjust RV1005 for equal spot size in both (cw and ccw) conditions, so that the focus point is in midrange position.

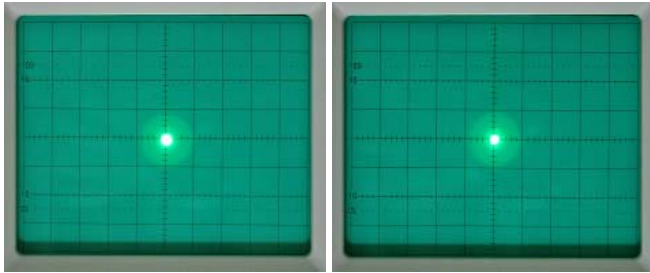

Fully counter clockwise

Fully clockwise

PS-Board 2



RV1005

RV1003

8 R6024: Astigmatism correction

- Locate and identify R6024 on CR-Board.
- Connect a 1MHz square wave signal with 25mV_{pp} at 50 Ω (HZ22) to input CHI.
- Set time base to 0.1 μs/div.
- Adjust FOCUS control for optimum sharpness.
- Adjust R6024 until the leading edge and the top of the signal have equal sharpness.
- Recheck range of FOCUS control.
- Adjust FOCUS control for optimum sharpness.

Note: This adjustment affects the CRT deflection sensitivity!

CR-Board

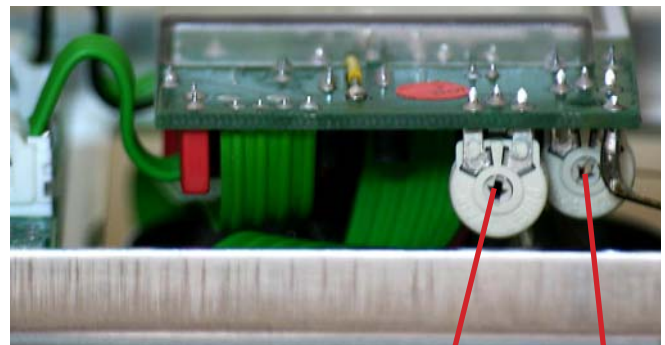

R6013

RV6024

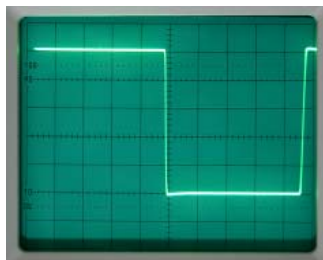

Correct

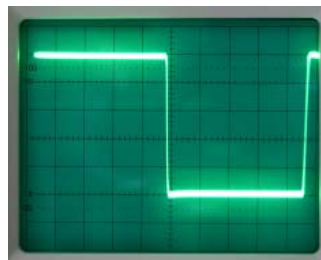
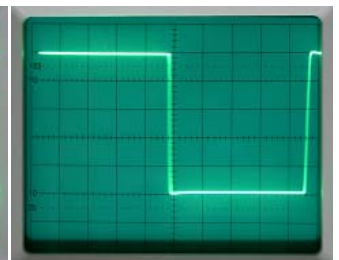
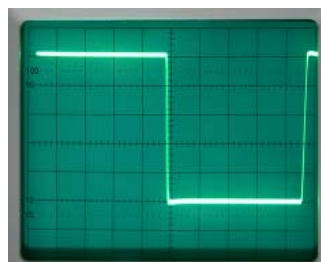
Incorrect
(horizontal out of focus)Incorrect
(vertical out of focus)

Correct focus cw

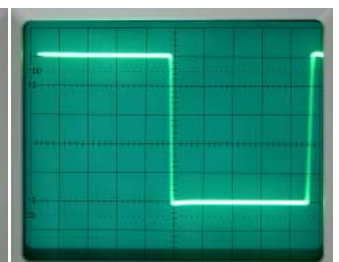

Correct focus ccw

9 RV4002: Focus control

- Locate and identify RV4002 on TB-Board.
- Connect a 1MHz square wave signal with 25mV_{pp} at 50 Ω (HZ22) to input CHI.
- Set time base to 0.1 μs/div.
- Set INTENS for medium intensity.
- Adjust FOCUS control for optimum sharpness.
- Set INTENS for maximum intensity.
- Do not change the FOCUS setting.
- Adjust RV4002 for optimum FOCUS (minimum trace diameter of the leading edge).

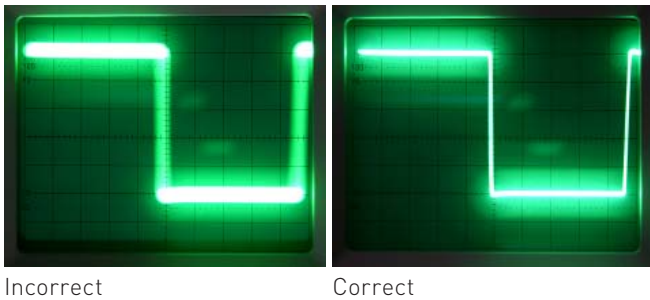

Incorrect

Correct

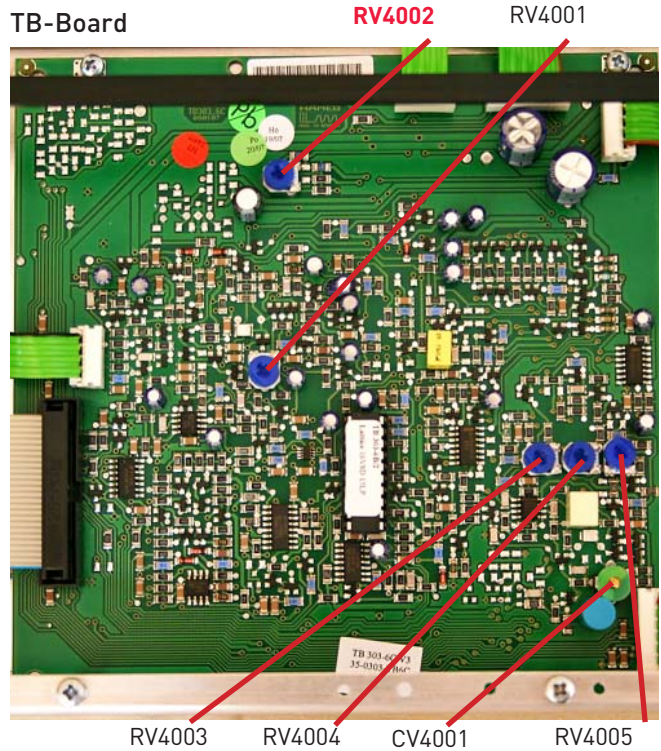

10 P2007: Y-Gain CH I at 5 mV/div

- Locate and identify P2007 on YP-Board.
- Connect a 25 mV_{pp} / 1 kHz square wave signal via a 50 Ω cable and a 50 Ω through-terminator to input channel I.
- Set input attenuator CH I to 5 mV/div.
- Set input coupling to DC.
- Rotate variable gain knob clockwise to CAL. position.
- Set input coupling to DC.
- Set time base to 0.5 ms/div.
- Adjust P2007 for 5 division signal height.
- Rotate variable gain knob fully counter clockwise (left stop).
- Check that the signal height is 2 divisions or less.
- Rotate variable gain knob to CAL. position.

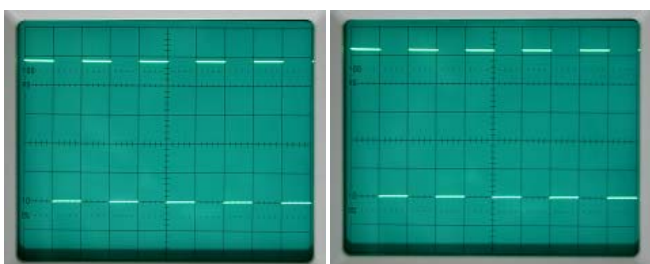
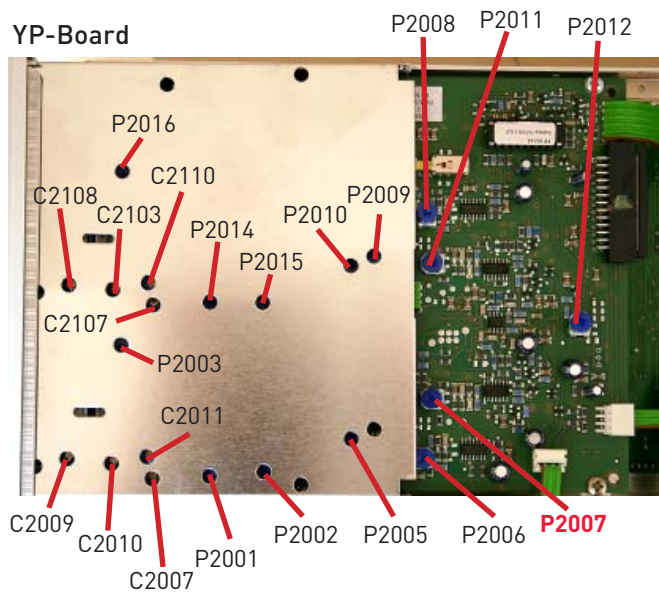

Incorrect (too low)

Incorrect (too high)

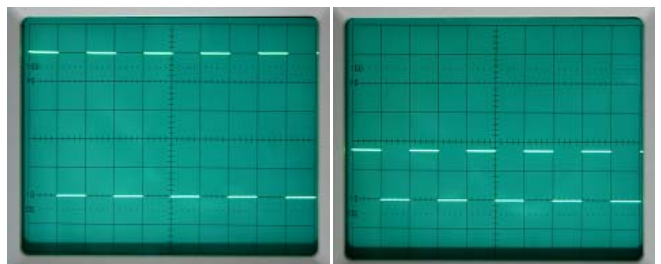

Correct

2.5 : 1 signal < 2div

11 P2002: Y-Gain CH I at 2 mV/div

- Locate and identify P2007 on YP-Board.
- Connect a 10 mV_{pp} / 1 kHz square wave signal via a 50 Ω cable and a 50 Ω through-terminator to input channel I.
- Set input attenuator CH I to 5 mV/div.
- Rotate variable gain knob clockwise to CAL. position.
- Set input coupling to DC.
- Set time base to 0.5 ms/div.
- Press Y-MAG x5 channel I pushbutton (IN position).
- Adjust P2002 for 5 division signal height.
- Rotate variable gain knob fully counter clockwise (left stop).
- Check that the signal height is 2 divisions or less.
- Rotate variable gain knob to CAL. position.

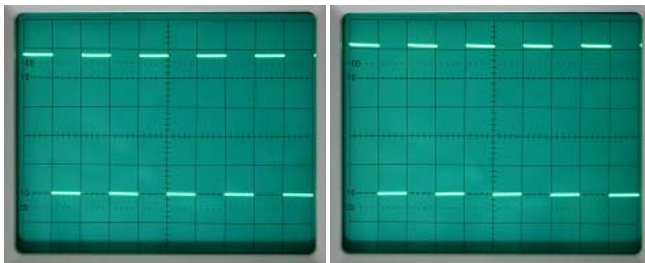
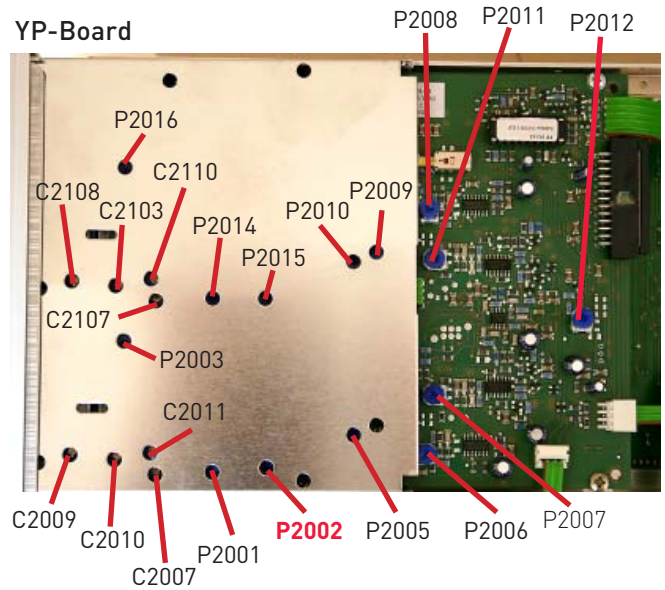

Incorrect (too low)

Incorrect (too high)

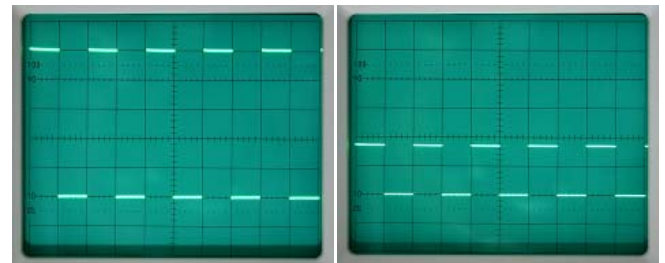

Correct

2.5 : 1 signal < 2div

12 P2003: Channel I Y-MAG. x5 balance

- Locate and identify P2003 on YP-Board.
- Set input attenuator CH I to 5 mV/div.
- Press channel I GND pushbutton (IN position).
- Set input coupling of CH I to DC.
- Set trace with Y-POS I control to the horizontal centre line of the graticule.
- Press and release the CHI Y MAG x5 pushbutton and adjust P2003 for no trace movement.

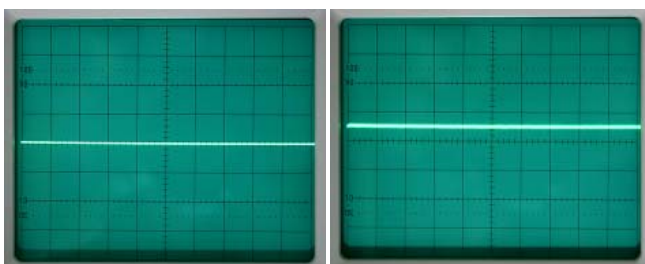
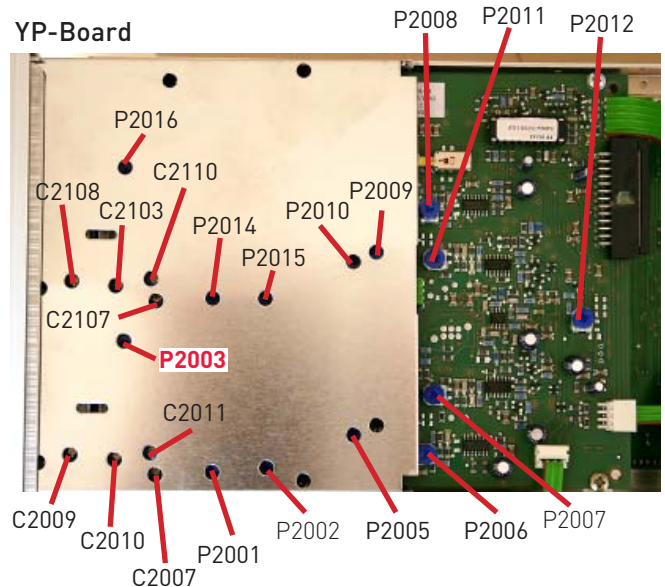

x1 (active) x5 incorrect

x1 x5 (active) incorrect

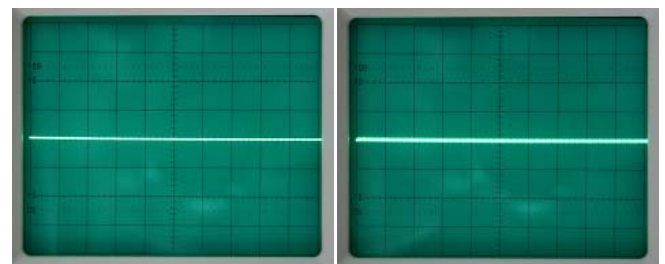

x1 (active) x5 correct

x1 x5 (active) correct

13 P2001: 100 Hz square wave CH I

- Locate and identify P2001 on YP-Board.
- Connect a 25 mV_{pp} / 100 Hz square wave signal via a 50 Ω cable and a 50 Ω through-terminator to input channel I.
- Set input attenuator CH I to 5 mV/div.
- Set input coupling to DC.
- Set time base to 2 ms/div.
- Adjust P2001 for a flat top on the square wave signal.

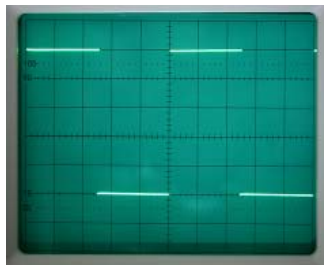
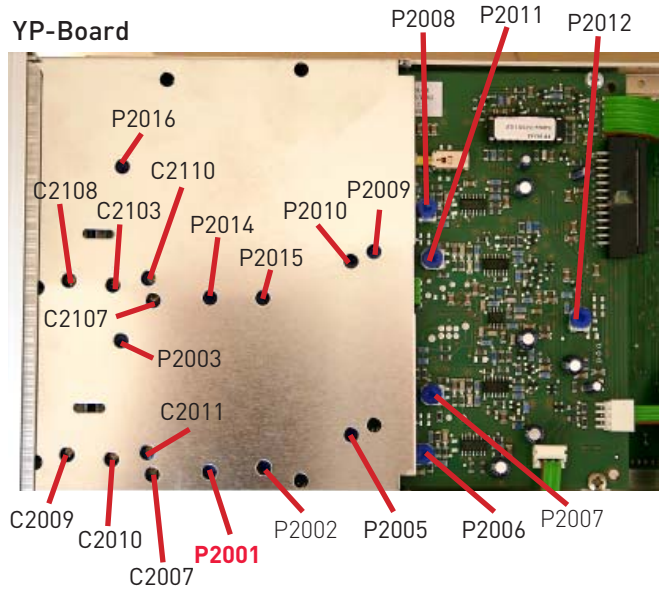

Correct

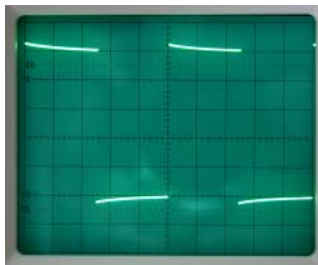

Overcompensate

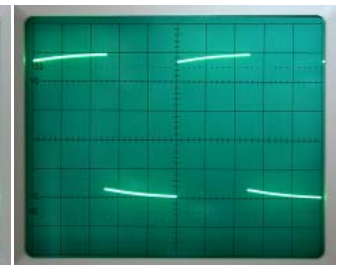

Undercompensate

14 P2005: Variable balance CH I

- Locate and identify P2005 on YP-Board.
- Set input attenuator CH I to 5 mV/div.
- Press channel I GND pushbutton (IN position).
- Set trace with Y-POS I control to the horizontal centre line of the graticule.
- Rotate variable gain knob of channel I continuously fully counter clockwise (left stop) and clockwise (right stop) and adjust P2005 for equal trace position (no vertical trace shift).

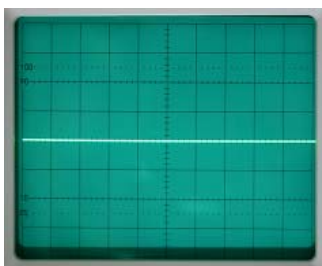
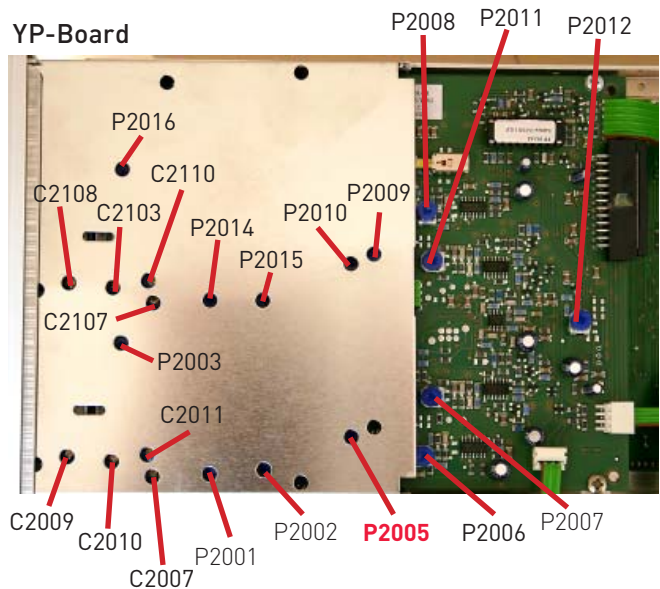

CW incorrect

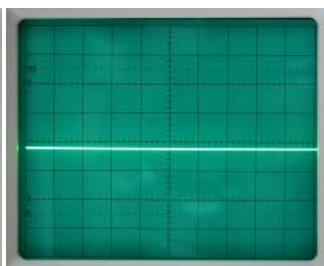

CCW incorrect

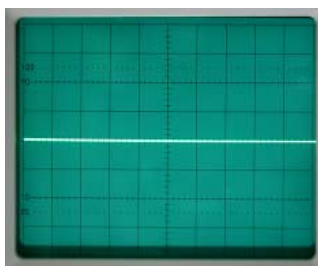

CW correct

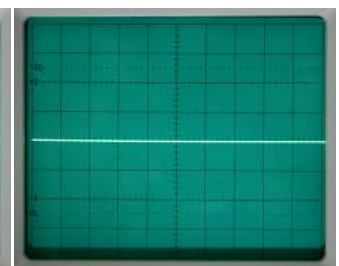

CCW correct

15 C2011/C2007: 10:1 Attenuator compensation CH I

- Set attenuator CH I to 5 mV/div.
- Set amplitude calibrator to 1 kHz and connect a 2:1 pre-attenuator (HZ23) via 50 Ω cable to input of CH I.
- Set amplitude calibrator output voltage to 50 mV_{pp} (25 mV_{pp} at the 2:1 pre-attenuator output) terminated with 1M Ω (oscilloscope input impedance).
- Adjust trimmer in pre-attenuator for a flat square wave top.
- This adjustment must not be changed during the following adjustment.
- Locate and identify trimmers C2011 and C2007 for CH I on YP-Board.
- Set input coupling to DC.
- Set time base to 2 ms/div.
- Set attenuator CH I to 50 mV/div.
- Set amplitude calibrator output voltage to 0.5 V_{pp} (0.25 V_{pp} at the 2:1 pre-attenuator output) terminated with 1M Ω (oscilloscope input impedance).
- Adjust C2011 for a flat top.
- Adjust C2007 for a leading edge without overshoot.
- Repeat C2011 and C2007 adjustment until optimum is obtained.

Do not change the 2:1 (HZ23) pre-attenuator adjustment and continue with item 16.

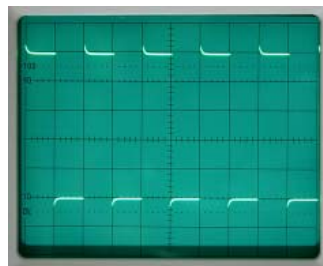
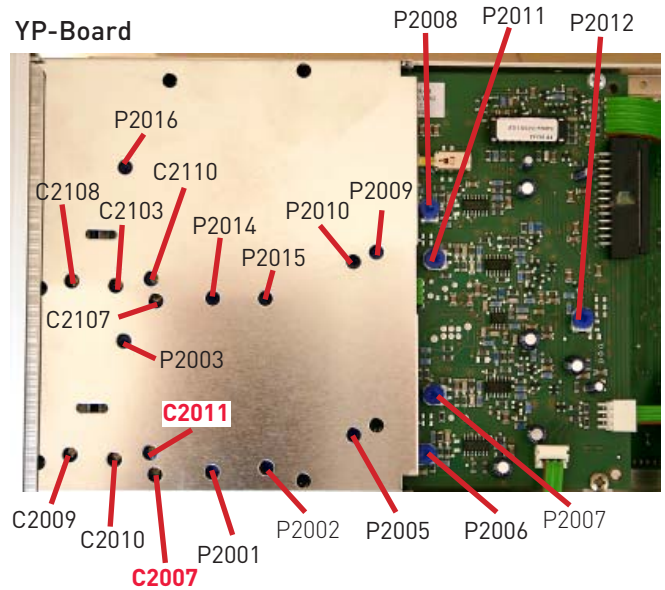

2 : 1 overcompensate

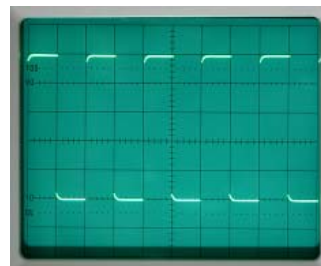

2 : 1 undercompensate

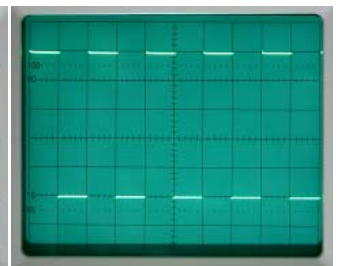

2 : 1 correct

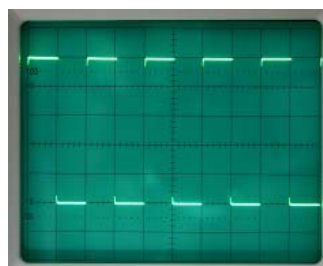

C2007 undercompensate

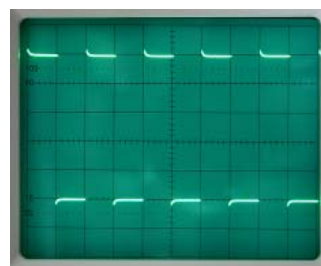

C2011 overcompensate

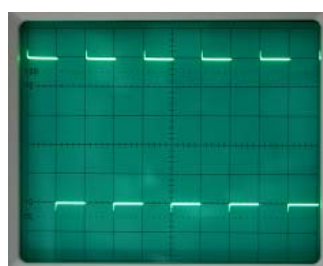

C2007 overcompensate

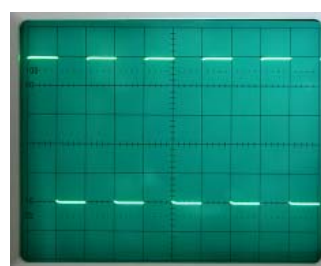

C2011 undercompensate

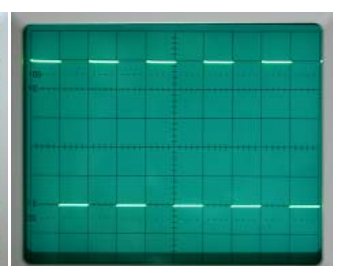

Correct

16 C2009/C2010: 100:1 Attenuator compensation CH I

Do not adjust until the adjustment of item 15 has been made.

- Locate and identify trimmers C2009 and C2010 for CH I on YP-Board.
- Set input coupling to DC.
- Set attenuator CH I to 0.5 V/div.
- Set amplitude calibrator output voltage to $5 V_{pp}$ ($2.5 V_{pp}$ at the 2:1 pre-attenuator output) terminated with $1M\Omega$ (oscilloscope input impedance).
- Adjust C2009 for a flat top.
- Adjust C2010 for a leading edge without overshoot.
- Repeat C2009 and C2010 adjustment until optimum is obtained.

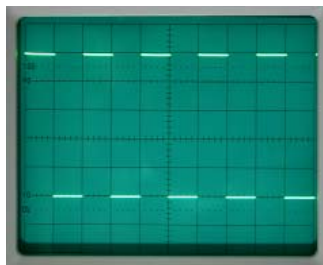
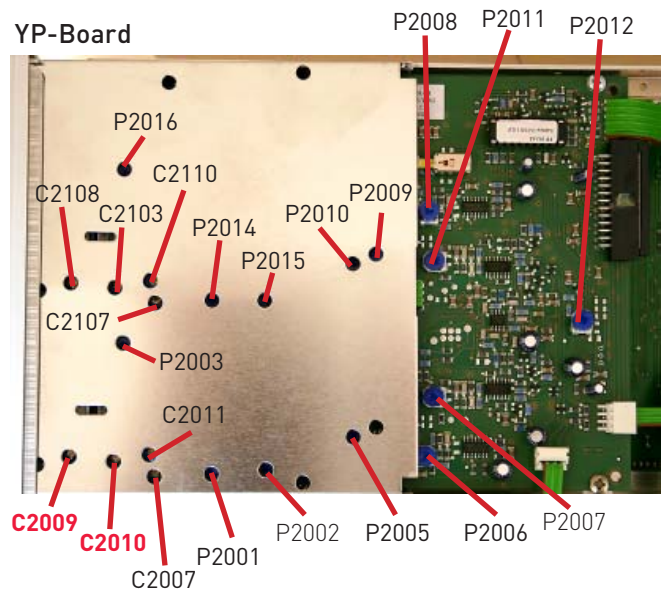

Correct

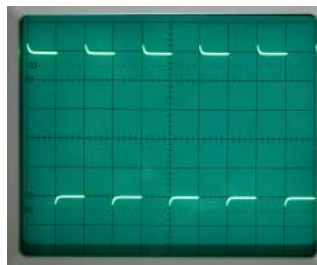

C2009 overcompensate

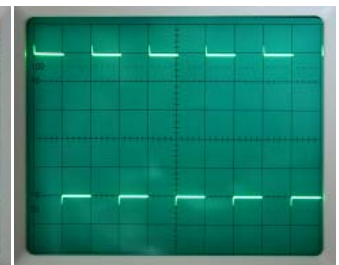

C2010 overcompensate

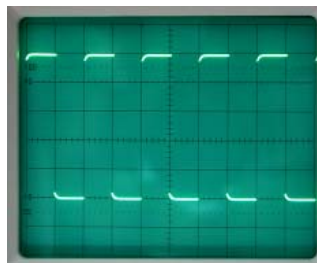

C2009 undercompensate

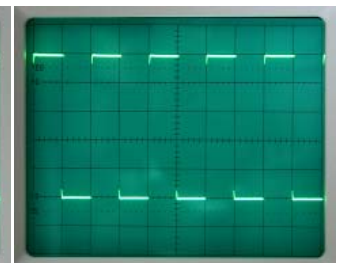

C2010 undercompensate

17 P2011: Y-Gain CH II at 5 mV/div

- Press CH I/II pushbutton (IN position) to select channel II.
- Locate and identify P2011 on YP-Board.
- Connect a 25 mV_{pp} / 1 kHz square wave signal via a 50 Ω cable and a 50 Ω through-terminator to input channel II.
- Set input attenuator CH II to 5 mV/div.
- Rotate variable gain knob clockwise to CAL. position.
- Set input coupling to DC.
- Set time base to 0.5 ms/div.
- Adjust P2011 for 5 division signal height.
- Rotate variable gain knob fully counter clockwise (left stop).
- Check that the signal height is 2 division or less.
- Rotate variable gain knob to CAL. position.

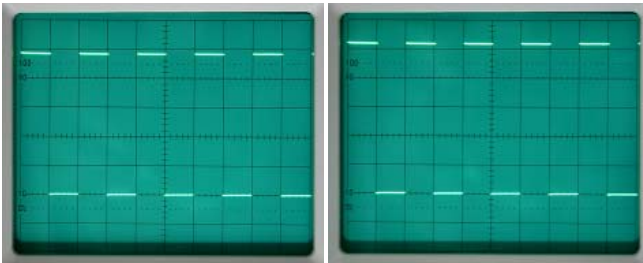
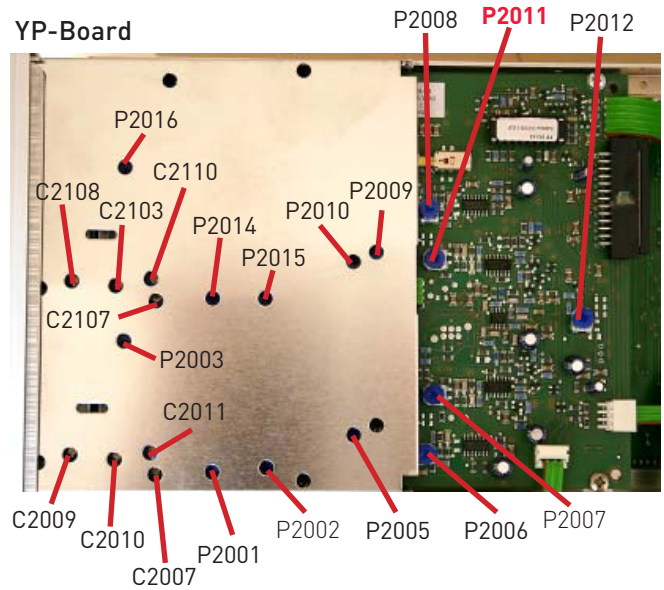

Incorrect (too low)

Incorrect (too high)

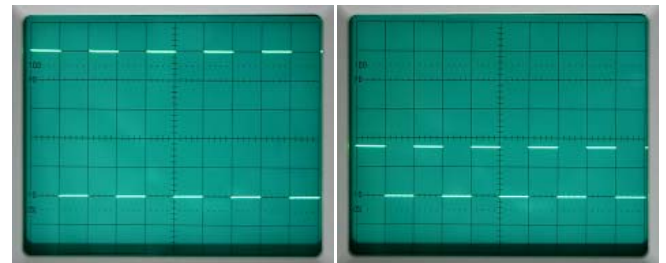

Correct

2.5 : 1 signal < 2div

18 P2015: Y-Gain CH II at 2 mV/div

- Press CH I/II pushbutton (IN position) to select channel II.
- Locate and identify P2015 on YP-Board.
- Connect a 10 mV_{pp} / 1 kHz square wave signal via a 50 Ω cable and a 50 Ω through-terminator to input channel II.
- Set input attenuator CH II to 5 mV/div.
- Rotate variable gain knob clockwise to CAL. position.
- Set input coupling to DC.
- Set time base to 0.5 ms/div.
- Press Y-MAG x5 channel II pushbutton (IN position).
- Adjust P2015 for 5 division signal height.
- Rotate variable gain knob fully counter clockwise (left stop).
- Check that the signal height is 2 division or less.
- Rotate variable gain knob to CAL. position.

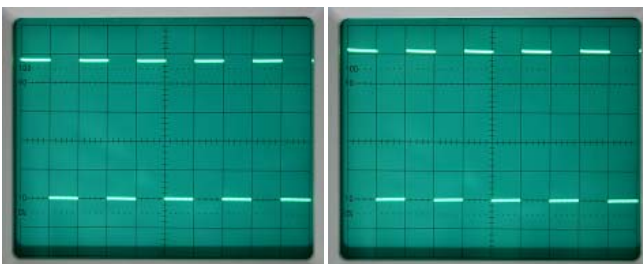
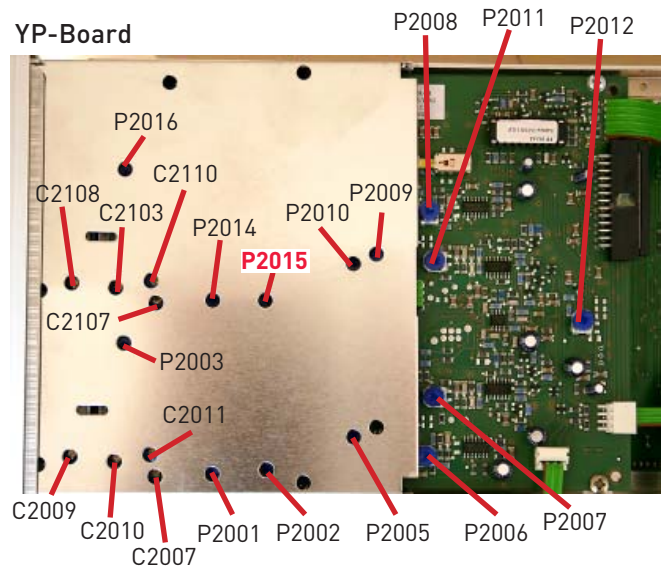

Incorrect (too low)

Incorrect (too high)

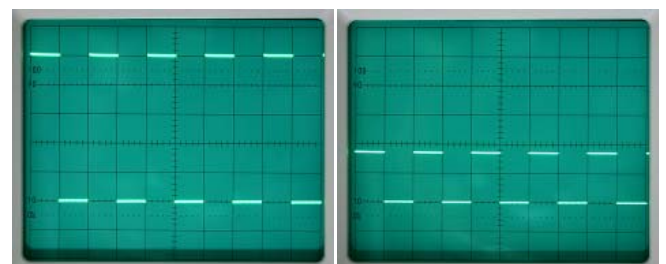

Correct

2.5 : 1 signal < 2div

19 P2016: Channel II Y-MAG. x5 balance

- Press CH I/II pushbutton (IN position) to select channel II.
- Locate and identify P2016 on YP-Board.
- Set input attenuator CH II to 5 mV/div.
- Press channel II GND pushbutton (IN position).
- Set input coupling to DC.
- Set trace with Y-POS II control to the horizontal centre line of the graticule.
- Press and release the CHII Y MAG x5 pushbutton and adjust P2016 for no trace movement.

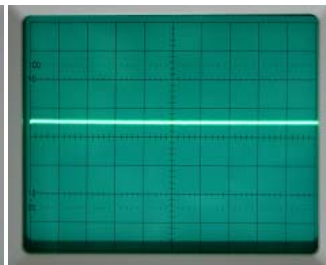
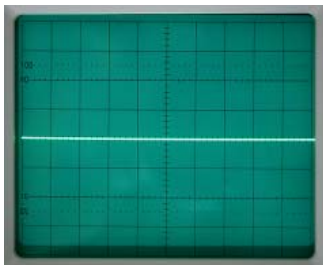
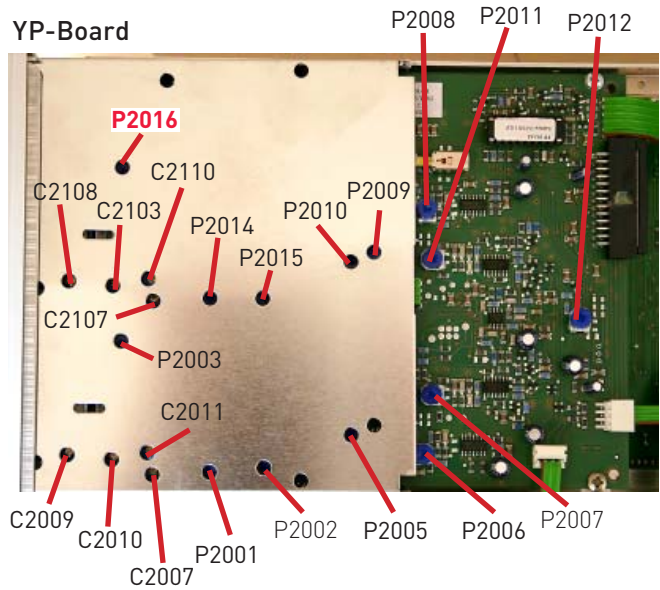

x1 (active) x5 incorrect

x1 x5 (active) incorrect

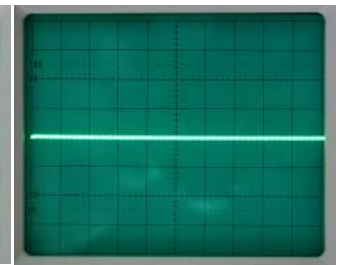
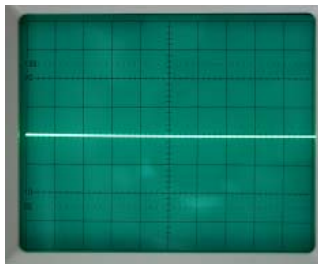

x1 (active) x5 correct

x1 x5 (active) correct

20 P2014: 100 Hz square wave CH II

- Press CH I/II pushbutton (IN position) to select channel II.
- Locate and identify P2014 on YP-Board.
- Connect a 25 mV_{pp} / 100 Hz square wave signal via a 50Ω cable and a 50Ω through-terminator to input channel II.
- Set input attenuator CH II to 5 mV/div.
- Set input coupling to DC.
- Set time base to 2 ms/div.
- Adjust P2014 for a flat top on the square wave signal.

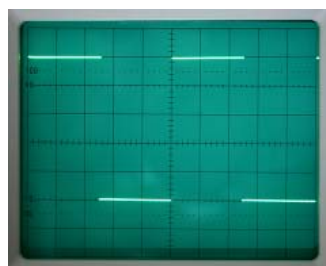
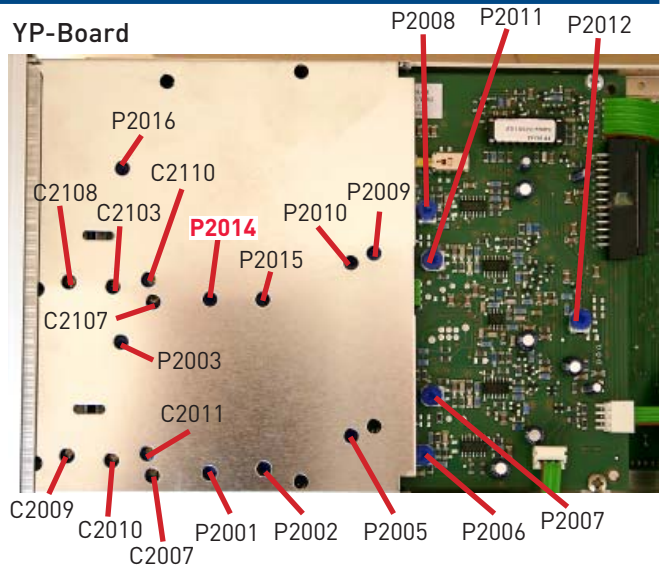

Correct

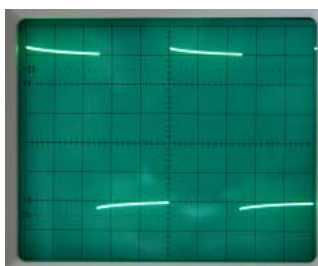

overcompensate

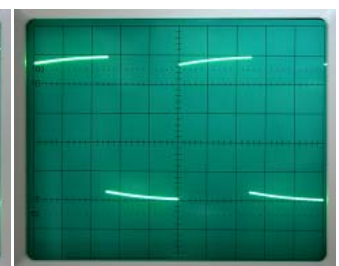

undercompensate

21 P2010: Variable balance CH II

- Press CH I/II pushbutton (IN position) to select channel II.
- Locate and identify P2010 on YP-Board.
- Set input attenuator CH II to 5 mV/div.
- Press channel II GND pushbutton (IN position).
- Set trace with Y-POS II control to the horizontal centre line of the graticule.
- Rotate variable gain knob of channel II continuously fully counter clockwise (left stop) and clockwise (right stop) and adjust P2010 for no trace movement.

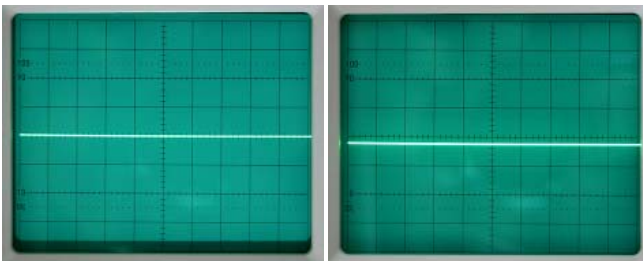
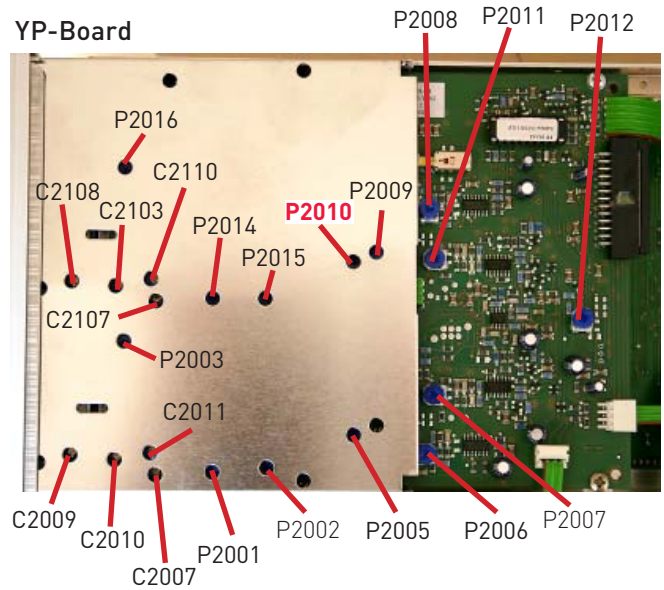

CW incorrect

CCW incorrect

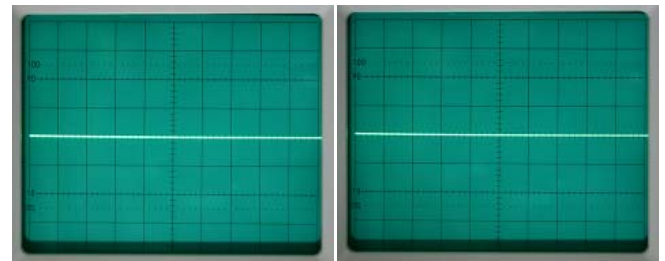

CW correct

CCW correct

22 P2009: Invert balance CH II

- Press CH I/II pushbutton (IN position) to select channel II.
- Locate and identify P2009 on YP-Board.
- Set input attenuator CH II to 5 mV/div.
- Press channel II GND pushbutton (IN position).
- Set trace with Y-POS II control to the horizontal centre line of the graticule.
- Press and release the INV. pushbutton and adjust P2009 for no trace movement.

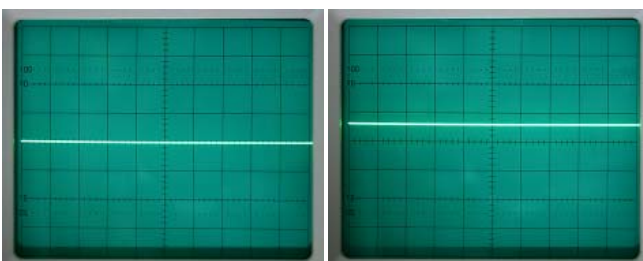
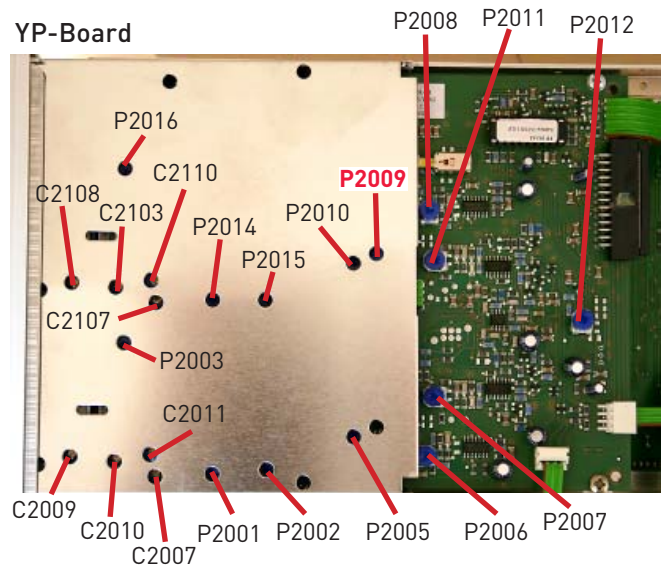

Not inverted incorrect

Inverted incorrect

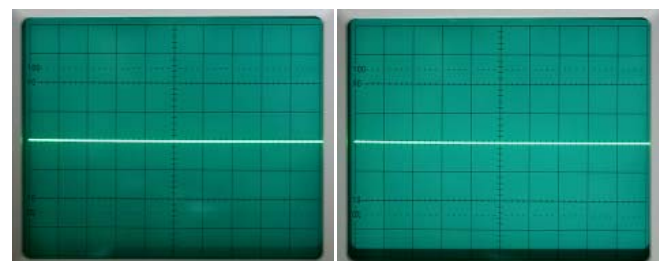

Not inverted correct

Inverted correct

23 C2110/C2107: 10:1 Attenuator compensation CH II

- Press CH I/II pushbutton (IN position) to select channel II.
- Set attenuator CH II to 5 mV/div.
- Set amplitude calibrator to 1kHz and connect a 2:1 pre-attenuator (HZ23) via 50Ω cable to input of CH II.
- Set amplitude calibrator output voltage to 50 mV_{pp} (25 mV_{pp} at the 2:1 pre-attenuator output) terminated with 1MΩ (oscilloscope input impedance).
- Adjust trimmer in pre-attenuator for a flat square wave top.
- This adjustment must not be changed during the following adjustment.
- Locate and identify trimmers C2110 and C2107 for CH II on YP-Board.
- Set input coupling to DC.
- Set time base to 2 ms/div.
- Set attenuator CH II to 50 mV/div.
- Set amplitude calibrator output voltage to 0.5 V_{pp} (0.25 V_{pp} at the 2:1 pre-attenuator output) terminated with 1MΩ (oscilloscope input impedance).
- Adjust C2110 for a flat top.
- Adjust C2107 for a leading edge without overshoot.
- Repeat C2110 and C2107 adjustment until optimum is obtained.

Do not change the 2:1 (HZ23) pre-attenuator adjustment and continue with item 24.

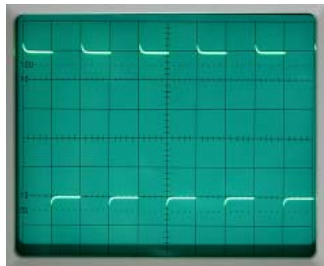
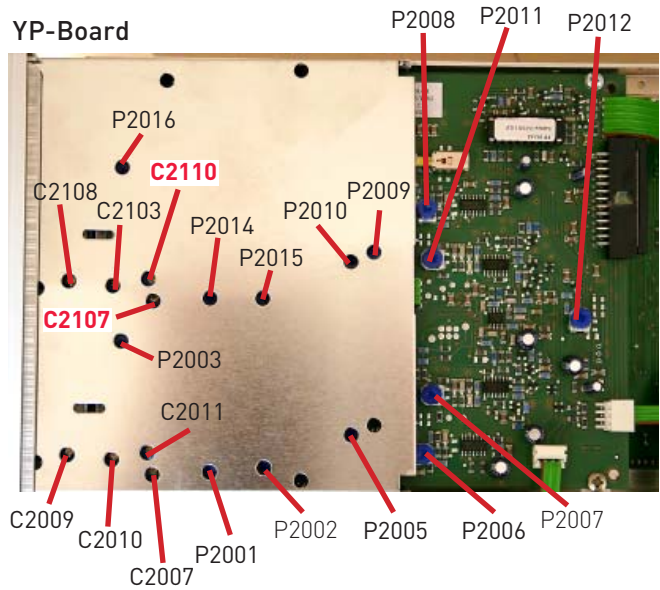

2 : 1 overcompensate

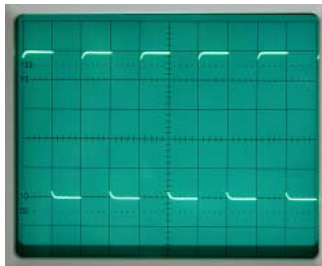

2 : 1 undercompensate

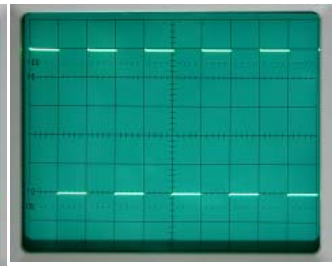

2 : 1 correct

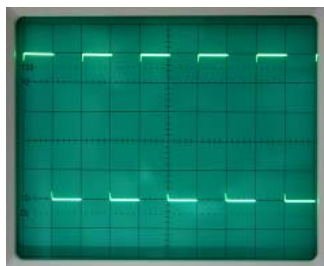

C2107 undercompensate

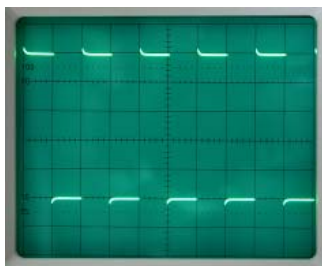

C2110 overcompensate

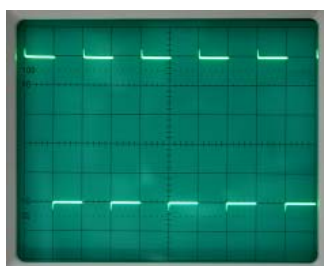

C2107 overcompensate

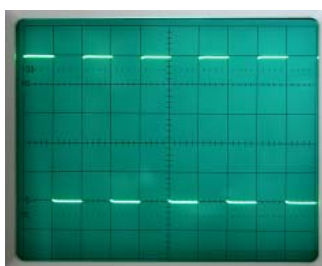

C2110 undercompensate

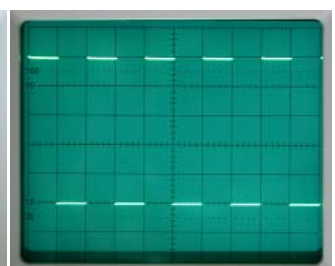

Correct

24 C2108/C2103: 100 : 1 Attenuator compensation CH II

Do not adjust until the adjustment of item 23 has been made.

- Locate and identify trimmers C2108 and C2109 for CH II on YP-Board.
- Set input coupling to DC.
- Set attenuator CH II to 0.5 V/div.
- Set amplitude calibrator output voltage to $5 V_{pp}$ ($2.5 V_{pp}$ at the 2:1 pre-attenuator output) terminated with $1M\Omega$ (oscilloscope input impedance).
- Adjust C2108 for a flat top.
- Adjust C2103 for a leading edge without overshoot.
- Repeat C2108 and C2103 adjustment until optimum is obtained.

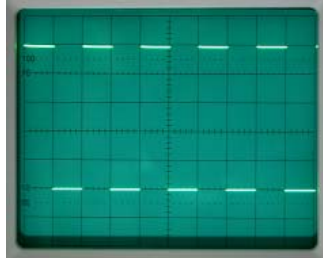

Correct

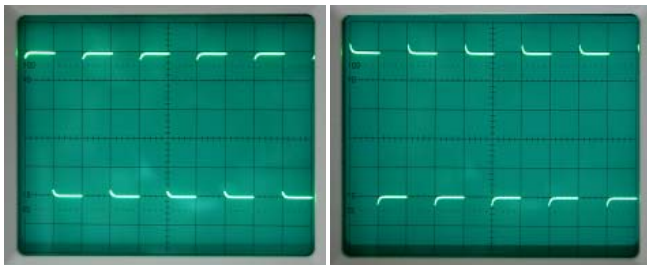

C2108 undercompensate

C2108 overcompensate

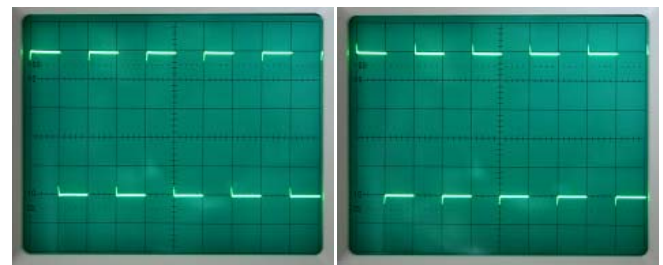
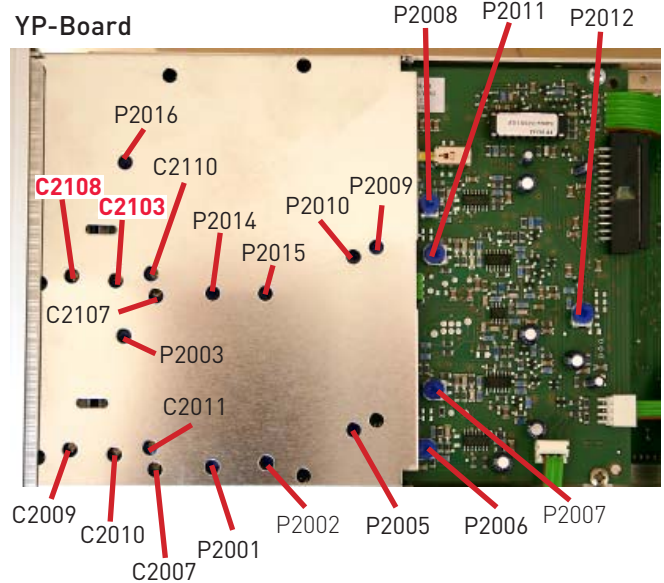

C2103 undercompensate

C2103 overcompensate

25 P2012: ADDition balance

- Press DUAL pushbutton (IN position).
- Locate and identify P2012 on YP-Board.
- Set input coupling CH I and II to GND.
- Move baseline channel I with Y-POS. I control 1 division above the horizontal centre line of the graticule.
- Move baseline channel II with Y-POS. II control 1 division below the horizontal centre line of the graticule.
- Release DUAL pushbutton (OUT position).
- Press ADD pushbutton (IN position).
- Adjust P2012 to move the baseline to the horizontal centre line of the graticule.

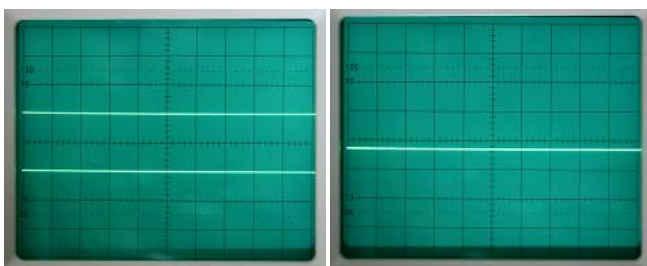

Basic position

Incorrect

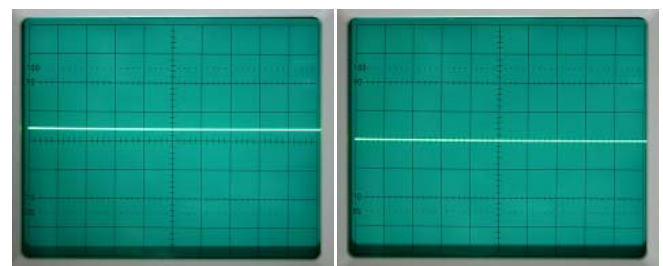
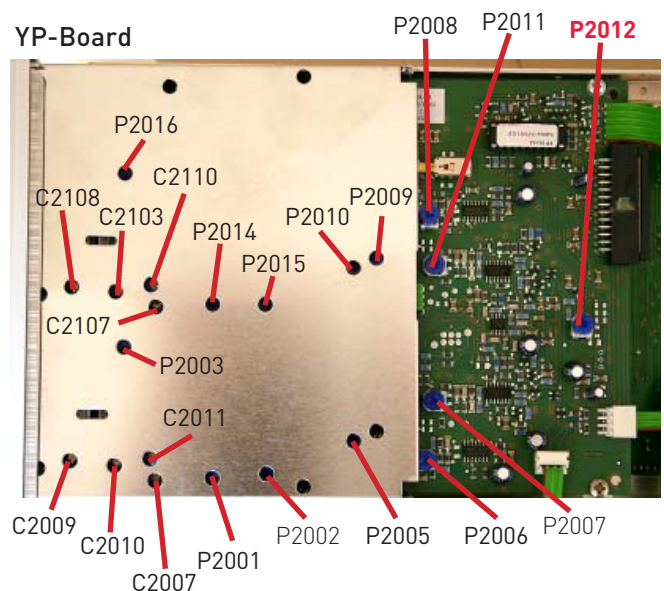

Incorrect

Correct

26 RV4005: Sawtooth start position

- Before measuring the sawtooth with a test oscilloscope (e.g. HM1000), set the test oscilloscope to the following settings:
DC input coupling.
Connect 10:1 probe to the test oscilloscope.
- Set test oscilloscope to 2 ms/div and 20 mV/div (0.2 V/div in combination with the 10:1 probe).
- Set test oscilloscope to automatic trigger mode and move the trace with Y- Pos. to a horizontal graticule line in the lower half of the screen and remember the GND (0V) position on e.g. using the ground symbol displayed by the readout.
- Locate and identify RV4005 on TB-Board.
- Locate and identify check point socket M9001 on XY-Board.
- Locate and identify pin 7 at socket M9001.
- Connect probe reference connector (crocodile clip) with chassis.
- Connect probe tip with pin 7 of socket M9001.
- Set instrument to 1 ms/div.
- Adjust RV4005 so that the sawtooth start position is at 0 Volt.

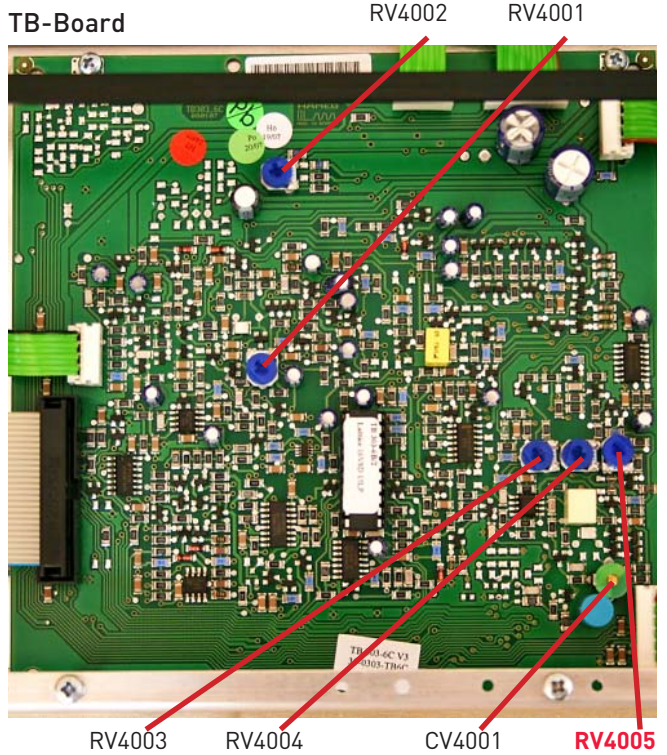

XY-Board

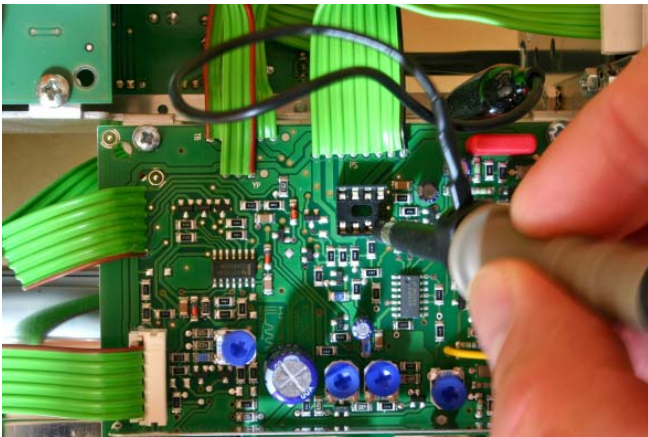

XY-Board

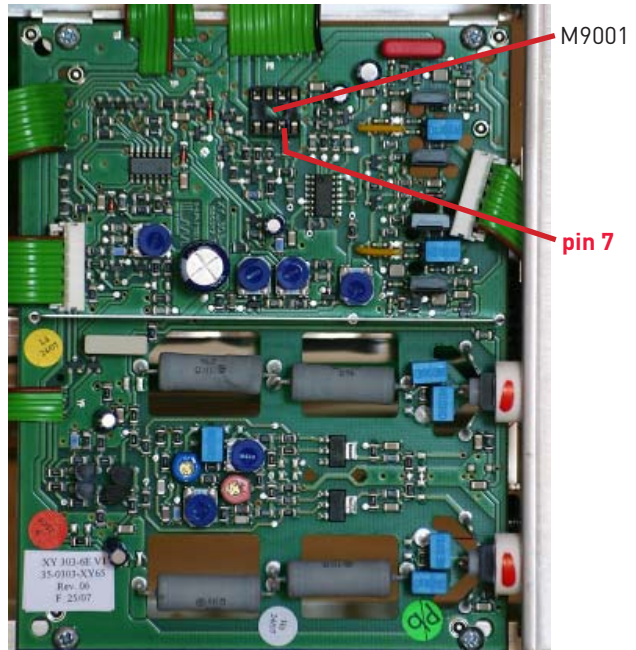

Correct



Incorrect

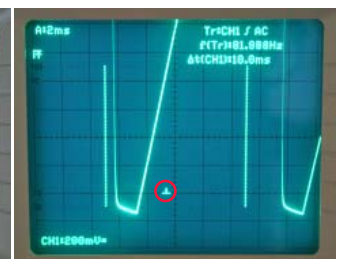

Incorrect

27 RV9004: X-Magnification x1

- Locate and identify RV9004 on XY-Board.
- Set time base to 0.2 ms/div.
- Adjust RV9004 for 10.2div trace length.

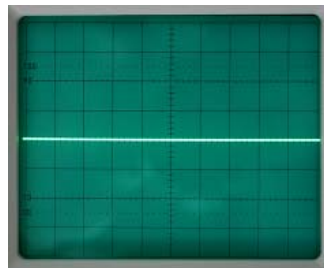

Correct

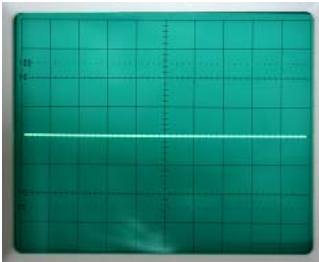

Incorrect

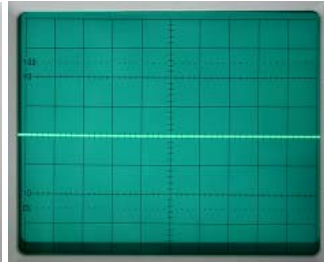

Incorrect

**28 CV4001: 0.5 μ s/div time base adjustment**

- Set input attenuator CH I to 0.1 V/div.
- Locate and identify CV4001 on the TB-Board.
- Set time base to 0.5 μ s/div and time base variable control to CAL position.
- Set Time Mark Generator to 0.5 μ s pulse interval ($f = 2$ MHz) and connect signal to CH I input.
- Move trace with X-POS. control so that the first time mark coincides with the first left graticule line of the screen.
- Adjust CV4001 so that each time mark coincides with a vertical graticule line.

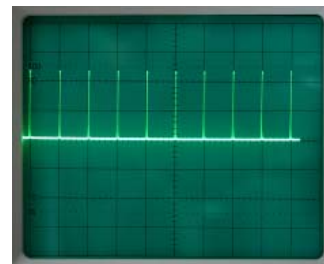

Correct

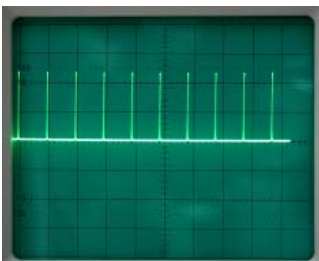

Incorrect

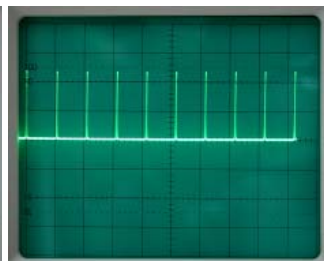

Incorrect

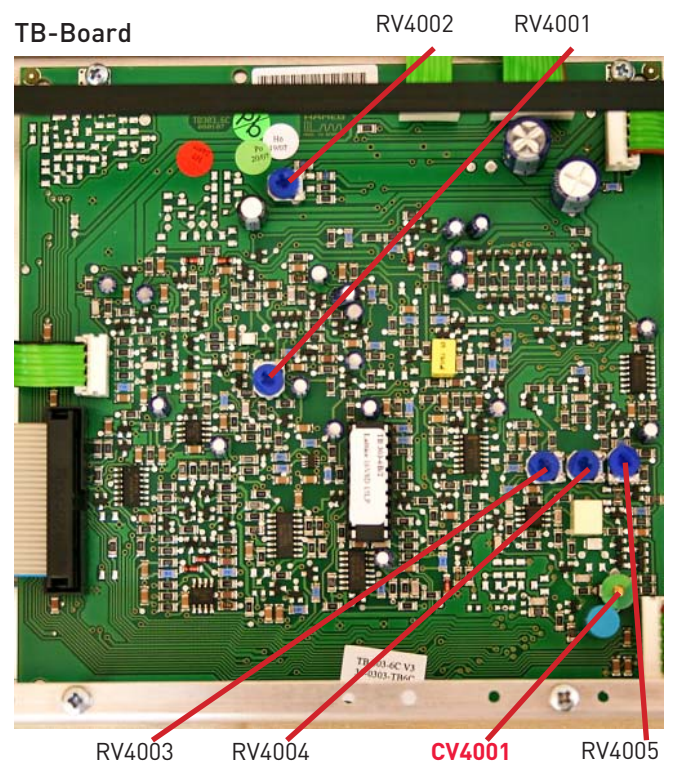

29 RV4004: 50 μ s/div time base adjustment

- Set input attenuator CH I to 0.1 V/div.
- Locate and identify RV4004 on TB-Board.
- Set time base to 50 μ s/div and time base variable control to CAL position.
- Set time mark generator to 50 μ s pulse interval ($f = 20$ kHz) and connect signal to CH I input.
- Move trace with X-POS. control so that the first time mark coincides with the left-most graticule line of the screen.
- Adjust RV4004 so that each time mark coincides with a vertical graticule line.
- Rotate time base variable control to the fully ccw position and check that more than 2.5 time marks per division are displayed.

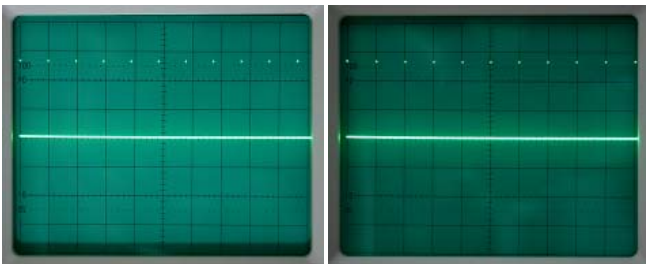
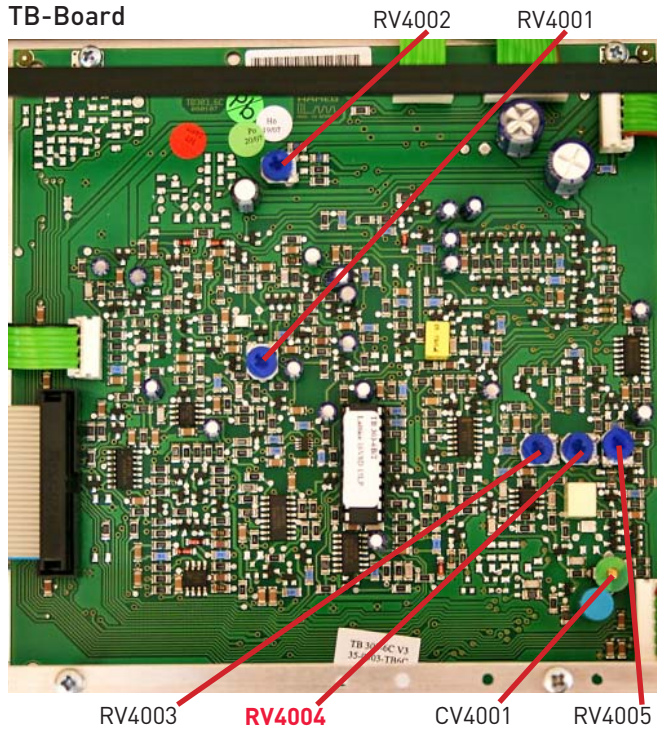

Incorrect

Correct

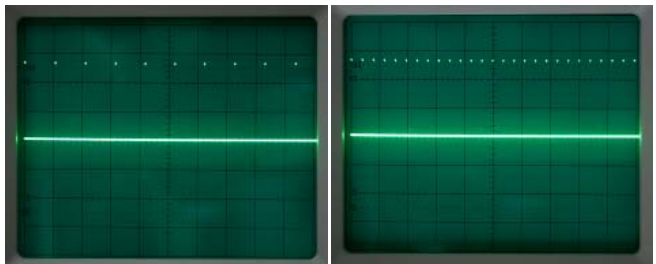

Incorrect

2.5 : 1 < 2.5 pulses pro div

30 RV4003: 50 ms/div time base adjustment

- Set input attenuator CH I to 0.1 V/div.
- Locate and identify RV4003 on TB-Board.
- Set time base to 50 ms/div and time base variable control to CAL position.
- Set time mark generator to 50 ms pulse interval ($f = 20$ Hz) and connect signal to CH I input.
- Move trace with X-POS. control so that the first time mark coincides with the left-most graticule line of the screen.
- Adjust RV4003 so that each time mark coincides with a vertical graticule line.

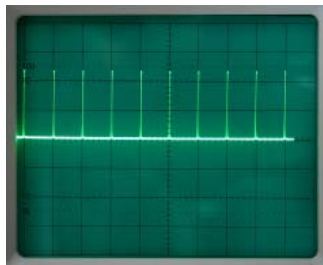

Correct

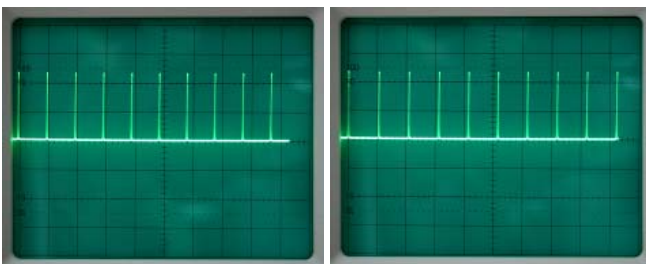

Incorrect

Incorrect



31 RV9003: X-Magnification x10

- Locate and identify RV9003 on the XY-Board.
- Press pushbutton X-Mag. x10 (IN position).
- Set time base to 50 $\mu\text{s}/\text{div}$ and time base variable control to CAL position.
- Set Time Mark Generator to 5 μs pulse interval ($f = 200 \text{ kHz}$) and connect the signal to the CH I input.
- Using X-POS control, move the first time mark to the left-most graticule line.
- Adjust RV9003 so that each time mark coincides with a vertical graticule line.
- Release X-MAG. x10 pushbutton to the OUT position.

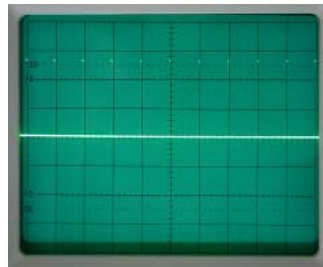

Correct

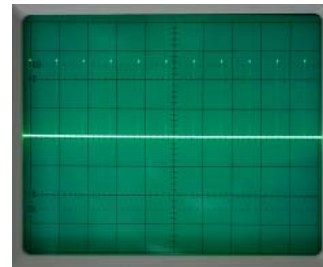

Incorrect

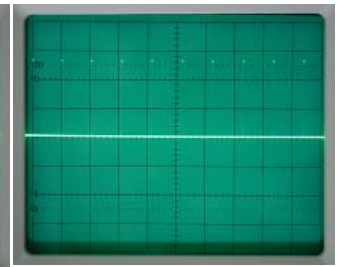

Incorrect

32 C9026, C9027: X-Magnification x10 linearity

- Locate and identify C9026 and C9027 (2 wires close to the X final amplifier transistors) on XY-Board.
- Set time base to 0.5 $\mu\text{s}/\text{div}$.
- Press MAG x10 pushbutton (IN position).
- Connect a 10 mV, 35 MHz sine wave signal via a 50 Ω cable and a 50 Ω through-terminator to input channel I.
- Check that the sine wave signal is displayed with a height of approx. 3-4 div.
- Set Y-POS. I knob so that the signal is displayed at the screen centre.
- Turn X-POS. knob and watch if the sine wave signal is compressed and expanded when being moved (accordion effect).
- If such an effect is visible, carefully adjust the wires with a fully isolated tool (screwdriver) until the effect is removed.

XY-Board

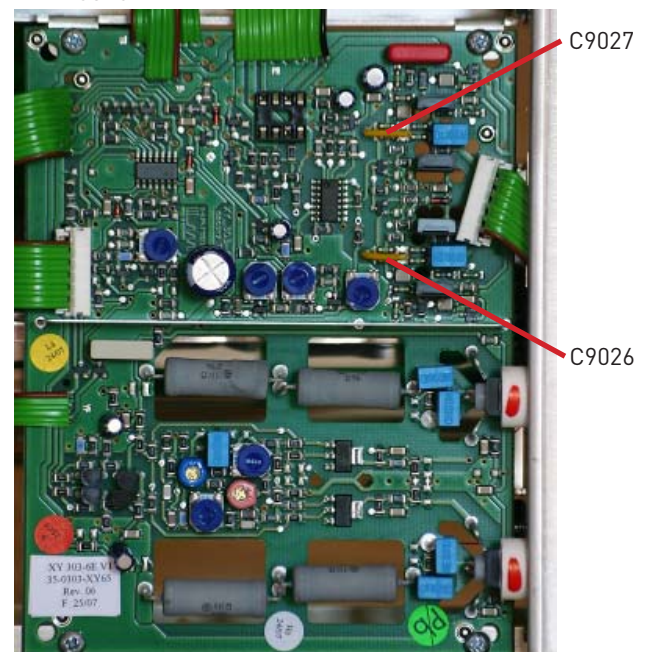

33 RV9002: X-Gain Adjustment in XY-Mode

- Locate and identify RV9002 on XY-Board.
- Connect a 25 mV_{pp} / 1 kHz square wave signal via a 50Ω cable and a 50Ω through-terminator to input channel I.
- Set input attenuator CH I to 5 mV/div.
- Rotate variable gain knob clockwise to CAL. position.
- Set input coupling to DC.
- Press X-Y pushbutton (IN position).
- Move both dots displayed close to the screen centre.
- Adjust RV9002 for 5 division dot spacing.

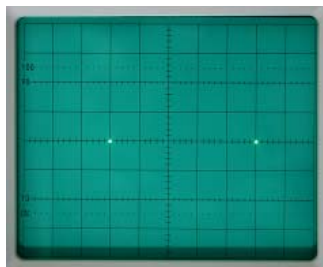

Correct

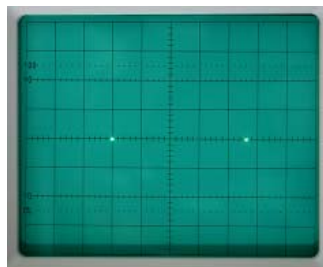

Incorrect

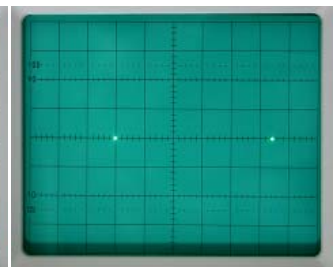

Incorrect

34 RV4001: Trigger-Symmetry

- Locate and identify RV4001 on the TB-Board.
- Connect a 25mV_{pp} , 50 kHz sine wave signal to input CH I.
- Set attenuator CH I to 5 mV/div.
- Set input coupling CH I to AC.
- Set time base to 50 $\mu\text{s}/\text{div}$.
- Set trigger coupling to AC.
- Check that the AT/NM pushbutton is in AT (automatic trigger) position (pushbutton switch OUT).
- Set LEVEL control to centre position.
- Reduce signal height to 0.5 div by switching the attenuator to 50 mV/div.
- Adjust RV4001 for a triggered signal display.
- Press and release SLOPE pushbutton and adjust RV4001 for correct triggering on both SLOPE conditions.
- Reduce signal height carefully by turning the variable gain knob to the left (ccw) and adjust RV4001 for minimum signal height triggering in both SLOPE settings.
- Check that triggering is performed with a signal height less than .5 division.

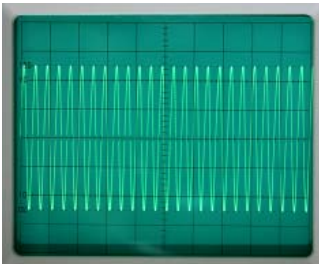

50 kHz @ 5 mV/div

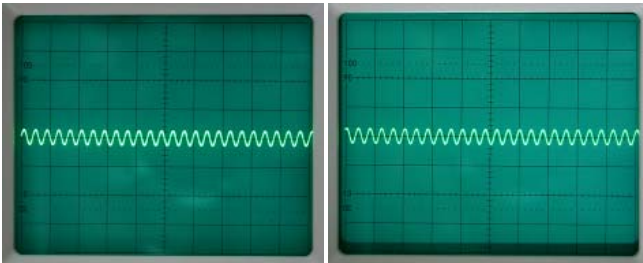
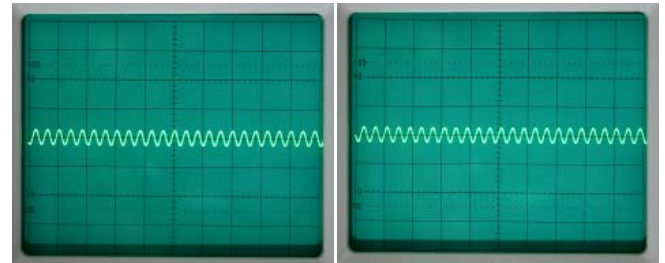
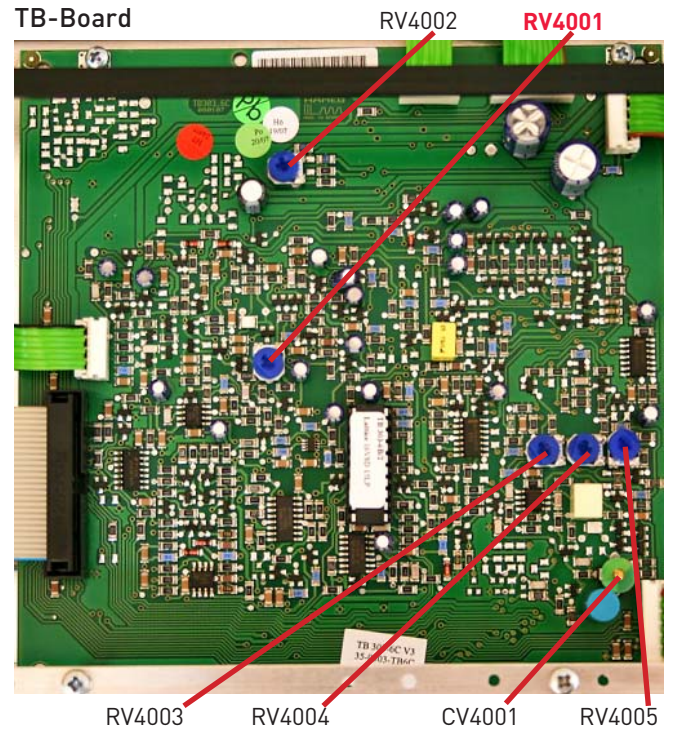
50 mV/div Level ccw
Slope +50 mV/div Level cw
Slope +50 mV/div Level ccw
Slope -50 mV/div Level cw
Slope -

35 P2006: DC-Trigging CH I

- Locate and identify P2006 on YP-Board.
- Connect a 50 kHz sine wave signal to input CH I.
- Set time base to 5 μ s/div.
- Set generator amplitude for a display height of 8 divisions.
- Check that input coupling CH I is set to AC.
- Set trigger coupling to AC.
- Press AT/NM (Automatic/Norm) pushbutton (IN position).
- Set LEVEL knob for a trigger point at the centre of the signal slope and note the position (reference).
- Set trigger coupling to DC.
- Adjust P2006 so that the trigger point (trace start) is in the same position as under AC coupling condition.

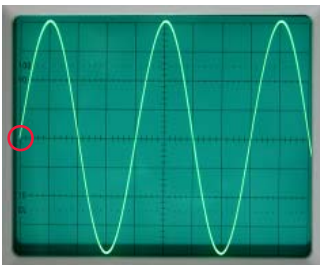
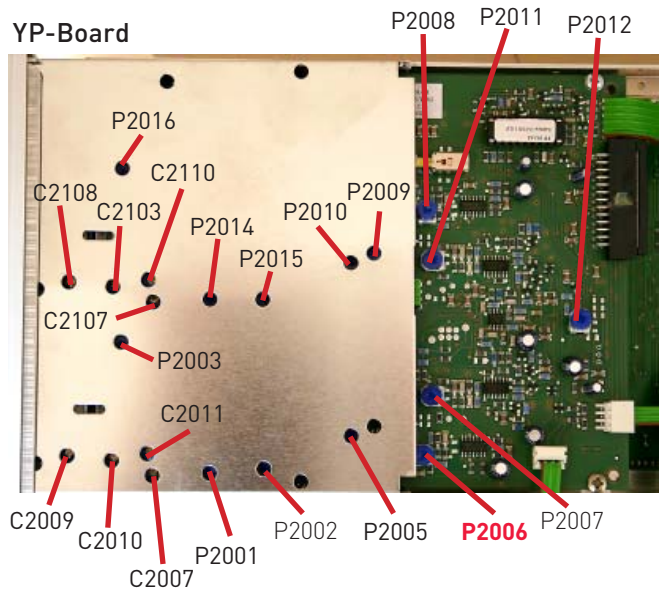

Reference

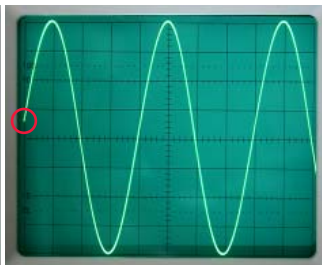

Incorrect

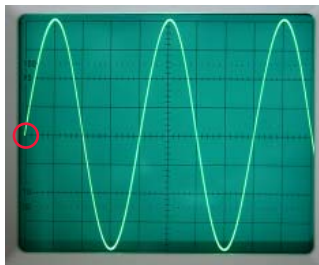

Correct

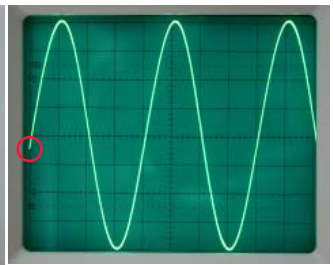

Incorrect

36 P2008: DC-Trigging CH II

- Locate and identify P2008 on YP-Board.
- Connect a 50 kHz sine wave signal to input CH I.
- Set time base to 5 μ s/div.
- Set generator amplitude for a display height of 8 divisions.
- Check that input coupling CH I is set to AC.
- Set trigger coupling to AC.
- Press AT/NM (Automatic/Norm) pushbutton (IN position).
- Set LEVEL knob for a trigger point at the centre of the signal slope and note the position (reference).
- Set trigger coupling to DC.
- Adjust P2008 so that the trigger point (trace start) is in the same position as under AC coupling condition.

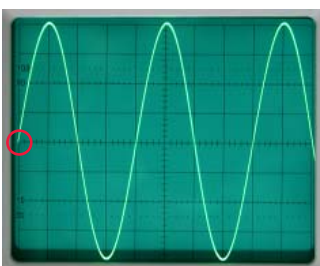
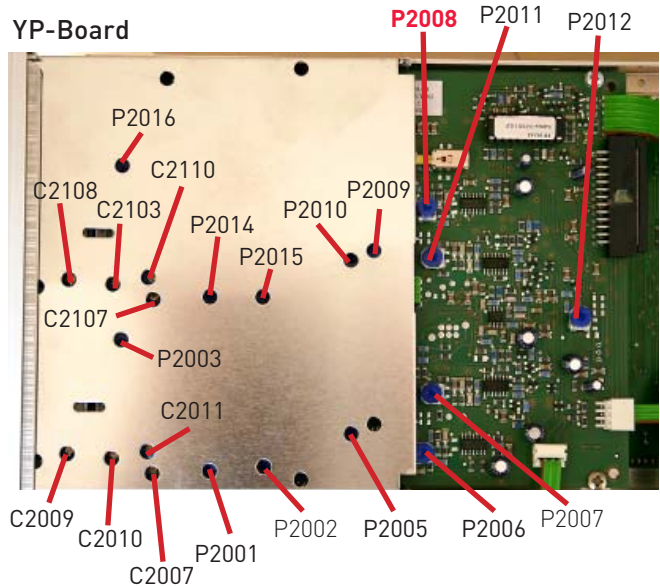

Reference

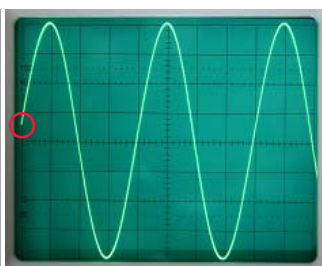

Incorrect

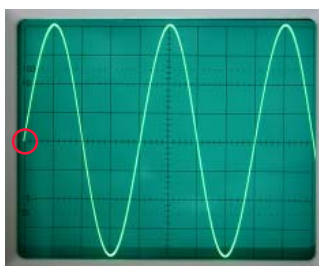

Correct

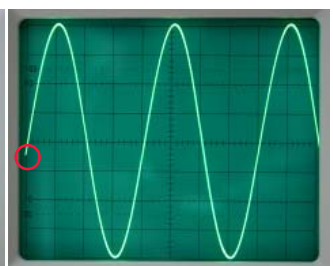

Incorrect

37 CV9001/9002, RV9006/9005: Y-Final Amplifier

- Connect a 25 mV_{pp}, 1MHz square wave signal via a 50Ω cable and a 50Ω through-termination to input CH I.
- Set input coupling to DC.
- Locate and identify CV9001, CV9002, RV9006 and RV9005 on XY-Board.
- Set time base to 0.1 μs/div.
- To avoid misadjustment, due to the removed cabinet, place a metal plate over the XY board to compensate the missing capacities to ground (cabinet).
- Adjust RV9005 and CV9002 for fast leading edge with minimum overshoot.
- Adjust RV9006 and CV9001 for flat top.
- Repeat both adjustments until an optimum display is obtained.

Continue with item 38.

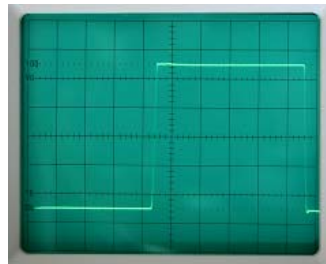

Correct

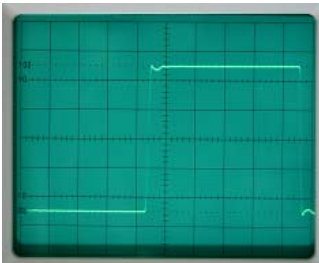

CV9001 incorrect

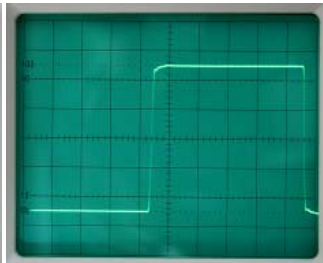

CV9002 incorrect



RV9005 incorrect

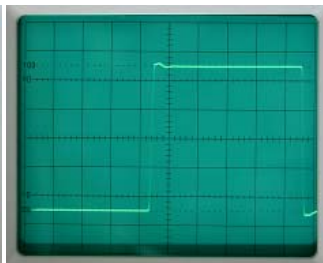

RV9006 incorrect



Cabinet capacity replacement

38 Y-Amplifier Bandwidth Check

- Connect a 40 mV_{pp}/50kHz sine wave signal from a Constant Amplitude Generator via a 50Ω through-termination to the input of CH I.
- Adjust the generator amplitude for 8 div. display height on the screen.
- Increase the generator frequency until the signal is displayed with 5.6 div. height (-3dB).
- Repeat the adjustments of item 37 if the frequency reading on the generator shows a value less than 35 MHz and check the Y-Amplifier Bandwidth again.
- Repeat the Y-Amplifier Bandwidth Check under channel II conditions.

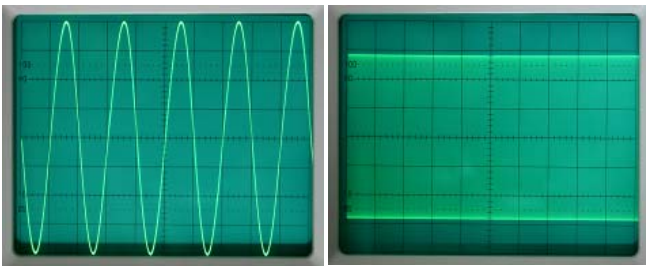

CH I 50 kHz

CH I -3dB > 35 MHz

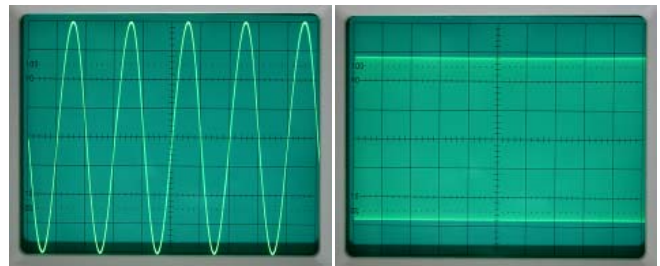

CH II 50 kHz

CH II -3dB > 35 MHz

39 RV9001: Component-Tester Y-Offset

- Press COMP. Tester pushbutton (IN position).
- Check that the COMP. Tester sockets are not short circuited.
- Locate and identify RV9001 on XY-Board.
- Adjust RV9001 to move the trace (approx. 8 division length) in vertical direction to the horizontal centre line of the graticule.

Note: Despite usage of Mu-metal shielding of the CRT, due to effects of the Earth's magnetic field small display deviations cannot be entirely avoided.

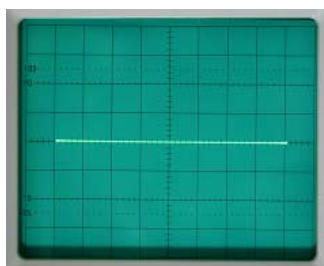

Correct

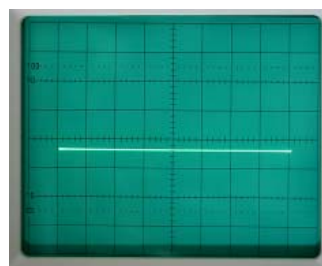

Incorrect

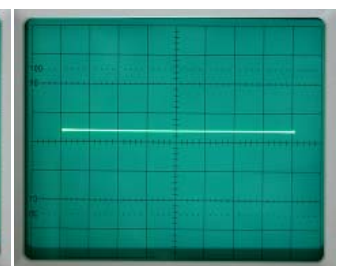

Incorrect

40 VR7003: Trace Rotation check

- Locate and identify VR7003 "TR" on front panel.
- Using Y-Pos.I and X-Pos. controls, move baseline to the centre of the graticule.
- Press CH I GND pushbutton (IN position).
- When turning VR7003, check that the range of inclination of the baseline is at least 1mm at left and right horizontal endpoints of the graticule.
- Adjust baseline to be displayed exactly parallel to the horizontal centre line of the graticule.

Do not change the instrument's position and continue with item 41.

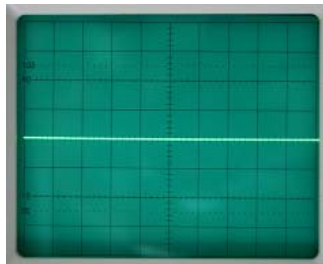

Correct

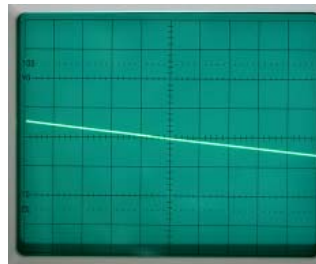

Incorrect

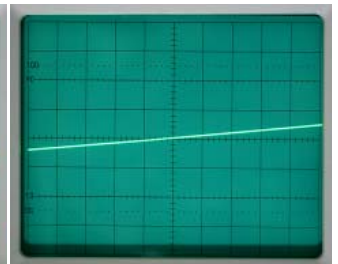

Incorrect

41 RV4501: Component-Tester trace inclination

- Check that the baseline is displayed exactly parallel to the horizontal centre line of the graticule.
- Press COMP. TESTER pushbutton (IN position).
- Check that the COMP. Tester sockets are not short circuited.
- Locate and identify RV4501 on CC-Board.
- Adjust RV4501 to rotate the trace (approx. 8 division length) parallel to the horizontal centre line of the graticule.

Note: Despite usage of Mu-metal shielding of the CRT, due to effects of the Earth's magnetic field small display deviations cannot be entirely avoided.

CC-Board



RV4501

RV4502

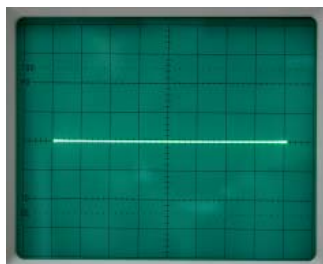

Correct

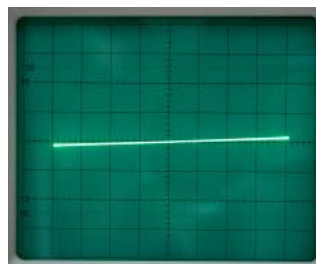

Incorrect

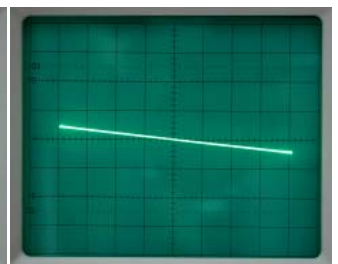

Incorrect

42 RV4502: Calibrator Output

- Locate and identify RV4502 on CC-Board.
- Connect the reference lead of a multimeter to chassis and the other lead with the inner lead of the 0.2 V_{pp} calibrator output socket.
- Select DC voltage measurement on the multimeter.
- Locate and identify IC4503 on CC-Board.
- Make a short from chassis to pin 4 (Preset) at IC4503.
- Adjust RV4502 for exactly 0.200 V_{DC} reading.
- Remove short and multimeter.

Please note!

Neither the calibrator signal frequency nor the pulse duty factor are specified.

CC-Board



RV4501

RV4502



43 XY mode: X-Amplifier Bandwidth Check

- Connect a 40 mV_{pp}/50 kHz sine wave signal from a Constant Amplitude Generator via a 50 Ω through-termination to the input of CH I.
- Set input attenuator CH I to 5 mV/div.
- Rotate variable gain knob clockwise to CAL. position.
- Set input coupling to DC.
- Press X-Y pushbutton (IN position).
- Adjust the generator amplitude for 8 div. trace length on the screen.
- Increase the generator frequency until the signal is displayed with 5.6 div. length (-3dB).
- Check that the generator frequency shows a value above 2.5 MHz.

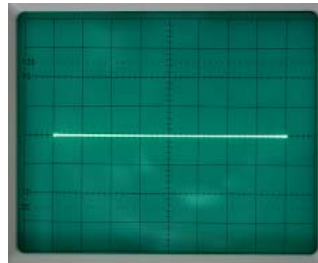

50 kHz

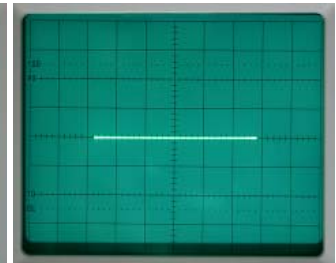

-3dB > 2.5 MHz

44 Trigger Filter Check

- Set time base to 1 ms/div.
- Connect a 1 kHz sine wave signal, 40 mV_{pp} amplitude, to input CH I and check for full screen deflection (80 mm at 5 mV/div).
- Set input attenuator CH I to 50 mV/div and check for 8 mm display height.
- Set trigger coupling to AC, DC and LF. The signal must always trigger.
- Set time base to 50 μs/div.
- Set sine wave generator to 50 kHz and 40 mV_{pp} output amplitude and check for 8mm display height.
- Set trigger coupling to AC and DC. The signal must always trigger.
- Select LF trigger coupling. Now the signal should not trigger.

45 Trigger Bandwidth Check

- Set time base to 0.1 $\mu\text{s}/\text{div}$, time base variable knob to CAL. position.
- Press X-MAG. x10 pushbutton (IN position).
- Set input coupling switch CH I to DC.
- Set trigger coupling to AC.
- Press AT/NM (Automatic/Norm) pushbutton (IN position).
- Set input attenuator CH I to 5 mV/div.
- Connect a 100 MHz sine wave signal to input CH I.
- Adjust generator output for 5 mm display height.
- Turn LEVEL knob until the oscilloscope triggers.

46 External Trigger Check

- Set time base to 50 $\mu\text{s}/\text{div}$.
- Set input attenuator CH I to 0.1 V/div.
- Connect a 50 kHz sine wave signal with an amplitude of 300 mV_{pp} via a 50 Ω through-terminator to input CH I and check for 3 div display height.
- Set LEVEL to midrange position.
- Check that the Trigger-LED (TR) is ON.
- Press TRIG. EXT. pushbutton. The Trigger-LED (TR) should now be OFF.
- Remove signal cable from input CH I and connect it to TRIG. EXT. socket. Do not change generator settings.
- Verify that the Trigger-LED (TR) is ON.

47 Video Trigger Check

- Set CH I input coupling switch to DC.
- Connect video signal with positive sync. pulses to input CH I.
- Set input attenuator CH I for 0.5 div display amplitude of the sync. pulses.
- Set trigger coupling switch to TV.
- Set time base to 5 ms/div for TV frame triggering.
- Check that trigger starts with vertical sync. pulses.
- Now approx. 2.5 frames should be visible.
- Change polarity of the video signal.
- Press SLOPE pushbutton (IN position).
- Again approx. 2.5 frames should be displayed triggered.
- Set time base to 20 $\mu\text{s}/\text{div}$ for TV line triggering.
- Now approx. 3 lines should be visible.
- Change polarity of video signal.
- Release SLOPE pushbutton to the OUT position.
- Again 3 lines should be displayed triggered.

Note:

The switch over from frame to line TV triggering is performed by the time base switch. In time base settings from 0.2 s/div to 0.2 ms/div TV frame triggering is selected. Line triggering is present from 0.1 ms/div to 0.1 $\mu\text{s}/\text{div}$.

48 Invert-Balance Check CH II

- Press CH I/II - TRIG. I/II pushbutton (IN position).
- Set attenuator CH II to 5 mV/div.
- Set input coupling CH II to GND.
- Using Y-POS.II control set trace to the horizontal centre line of the graticule.
- Press and release the INV. pushbutton. The baseline must not move more than 0.2 div. (2mm).

49 Variable-Balance Check CH I

- Set input coupling CH I to GND.
- Using Y-POS.I control set trace to the horizontal centre line of the graticule.
- Turn variable gain knob through the entire range. The baseline must not move more than 0.2 div. (2mm).

50 Variable-Balance Check CH II

- Press CH I/II - TRIG. I/II pushbutton (IN position).
- Set input coupling CH II to GND.
- Using Y-POS.II control set trace to the horizontal centre line of the graticule.
- Turn variable gain knob through the entire range. The baseline must not move more than 0.2 div. (2mm).

Oscilloscopes

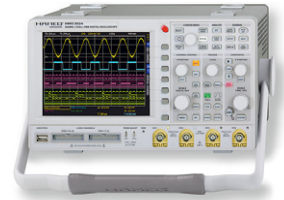

Spectrum Analyzer

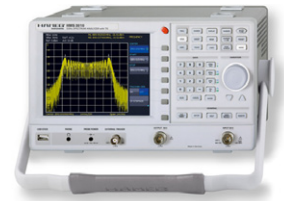

Power Supplies



Modular System
Series 8000



Programmable Instruments
Series 8100



authorized dealer

www.hameg.com

Subject to change without notice
Release: · 30032011

© HAMEG Instruments GmbH
A Rohde & Schwarz Company



DQS-Certification: DIN EN ISO 9001:2000
Reg.-Nr.: 071040 QM

HAMEG Instruments GmbH
Industriestraße 6
D-63533 Mainhausen
Tel +49 (0) 61 82 800-0
Fax +49 (0) 61 82 800-100
sales@hameg.com