

LG

COLOR MONITOR SERVICE MANUAL

CHASSIS NO. : CL-29

FACTORY MODEL: LB886F

MODEL: FLATRON L1800PM (LB886F-SL)

*() ID LABEL MODEL No.

CAUTION

BEFORE SERVICING THE UNIT,
READ THE **SAFETY PRECAUTIONS** IN THIS MANUAL.



CONTENTS

SPECIFICATIONS	2	ADJUSTMENT	13
PRECAUTIONS	3	TROUBLESHOOTING GUIDE	14
TIMING CHART	4	PRINTED CIRCUIT BOARD.....	21
OPERATING INSTRUCTIONS	5	EXPLODED VIEW.....	26
WIRING DIAGRAM	9	REPLACEMENT PARTS LIST	28
BLOCK DIAGRAM	10	PIN CONFIGURATION.....	34
DESCRIPTION OF BLOCK DIAGRAM.....	11	SCHEMATIC DIAGRAM.....	37

SPECIFICATIONS

1. LCD CHARACTERISTICS

Type	: TFT SXGA LCD
Size	: 18inch
Pixel Pitch	: 0.28(H) x 0.28(V)
Color Depth	: 8-bit, 16,777,216 colors
Electrical Interface	: LVDS
Surface Treatment	: Anti-Glare, Hard Coating (3H)
Operating Mode	: Normally Black
Backlight Unit	: Six-CCFL (Cold Cathode Fluorescent Lamp)

2. OPTICAL CHARACTERISTICS

2-1. Viewing Angle by Contrast Ratio ≥ 10

Left	: -60° min., -80°(Typ)
Right	: +60° min., +80°(Typ)
Top	: +60° min., +80°(Typ)
Bottom	: -60° min., -80°(Typ)

2-2. Luminance : 200(min)

2-3. Contrast Ratio : 200(min)

3. SIGNAL (Refer to the Timing Chart)

3-1. Sync Signal

• Type	: Separate TTL(Positive/Negative) Composite TTL(Positive/Negative) SOG (Sync On Green) Digital
--------	---------------------------------------------------------------------------------------------------------

3-2. Video Input Signal

1) Type	: R, G, B Analog
2) Voltage Level	: 0~0.71 V
a) Color 0, 0	: 0 Vp-p
b) Color 7, 0	: 0.467 Vp-p
c) Color 15, 0	: 0.714 Vp-p
3) Input Impedance	: 75 Ω

3-3. Operating Frequency

Horizontal	: 30 ~ 80kHz
Vertical	: 56 ~ 85Hz

4. POWER SUPPLY

4-1. Power Input

: AC 100~240V, 50/60Hz, 1.0A

4-2. Power Consumption

MODE	H/V SYNC	VIDEO	POWER CONSUMPTION	LED COLOR
POWER ON (NORMAL)	ON/ON	ACTIVE	less than 60 W	GREEN
STAND-BY	OFF/ON	OFF	less than 3 W	AMBER
SUSPEND	ON/OFF	OFF	less than 3 W	AMBER
OFF	OFF/OFF	OFF	less than 3 W	AMBER
POWER OFF	-	-	less than 3 W	OFF

5. ENVIRONMENT

5-1. Operating Temperature: 10°C~35°C (50°F~95°F)
(Ambient)

5-2. Relative Humidity : 10%~80%
(Non-condensing)

5-3. MTBF : 50,000 Hours(Min), Except Lamp

6. DIMENSIONS (with TILT/SWIVEL)

Width	: 397 mm (15.62")
Depth	: 237 mm (9.33")
Height	: 428 mm (16.85") -Min 508 mm (19.99") -Max

7. WEIGHT (with SPEAKER)

Net. Weight	: 8.8kg (19.40 lbs)
Gross Weight	: 11.3kg (24.91 lbs)

8. USB

Upstream : 1 port, Downstream : 2 port
Speed : Full-12Mbps, Low-1.5Mbps

9. SPEAKER

.RMS Audio Output: 2W(R+L)
.Input Sensivity: 0.7Vrms
.Speaker Impedance: 4

PRECAUTION

WARNING FOR THE SAFETY-RELATED COMPONENT.

- There are some special components used in LCD monitor that are important for safety. **These parts are marked  on the schematic diagram and the replacement parts list.** It is essential that these critical parts should be replaced with the manufacturer's specified parts to prevent electric shock, fire or other hazard.
- Do not modify original design without obtaining written permission from manufacturer or you will void the original parts and labor guarantee.

TAKE CARE DURING HANDLING THE LCD MODULE WITH BACKLIGHT UNIT.

- Must mount the module using mounting holes arranged in four corners.
- Do not press on the panel, edge of the frame strongly or electric shock as this will result in damage to the screen.
- Do not scratch or press on the panel with any sharp objects, such as pencil or pen as this may result in damage to the panel.
- Protect the module from the ESD as it may damage the electronic circuit (C-MOS).
- Make certain that treatment person's body are grounded through wrist band.
- Do not leave the module in high temperature and in areas of high humidity for a long time.
- The module not be exposed to the direct sunlight.
- Avoid contact with water as it may a short circuit within the module.
- If the surface of panel become dirty, please wipe it off with a softmaterial. (Cleaning with a dirty or rough cloth may damage the panel.)

WARNING

BE CAREFUL ELECTRIC SHOCK !

- If you want to replace with the new backlight (CCFL) or inverter circuit, must disconnect the AC adapter because high voltage appears at inverter circuit about 650Vrms.
- Handle with care wires or connectors of the inverter circuit. If the wires are pressed cause short and may burn or take fire.

CAUTION

Please use only a plastic screwdriver to protect yourself from shock hazard during service operation.

TIMING CHART

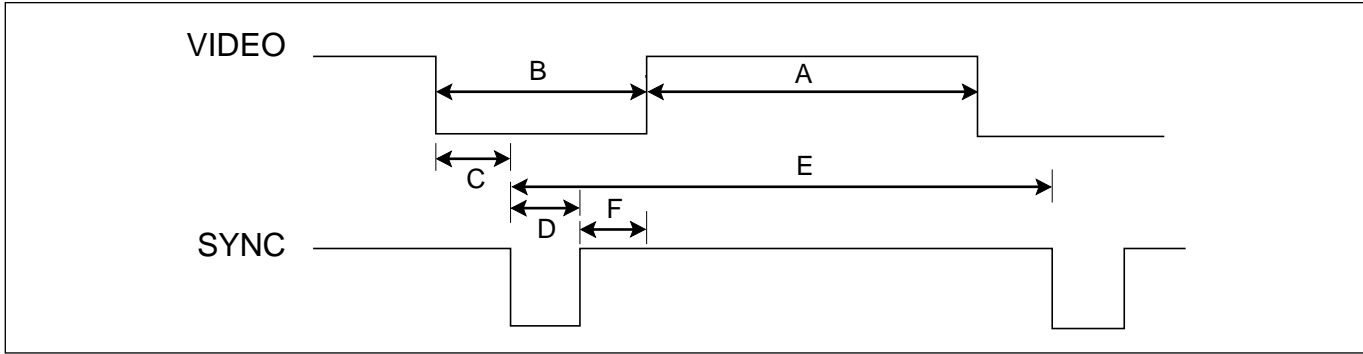

<< Dot Clock (MHz), Horizontal Frequency (kHz), Vertical Frequency (Hz), Horizontal etc... (µs), Vertical etc... (ms) >>

Mode	H/V Sort	Sync Polarity	Dot Clock	Frequency	Total Period (E)	Video Active Time (A)	Front Porch (C)	Sync Duration (D)	Back Porch (F)	Resolution
1	H	+	25.175	31.469	800	640	16	96	48	640x350 70Hz
	V	-		70.8	449	350	38	2	59	
2	H	-	28.321	31.468	900	720	18	108	54	720x400 70Hz
	V	+		70.8	449	400	12	2	35	
3	H	-	25.175	31.469	840	640	16	96	48	640x480 60Hz
	V	-		59.94	525	480	10	2	33	
4	H	-	31.5	37.5	840	640	16	64	120	640x480 75Hz
	V	-		75	500	480	1	3	16	
5	H	-	36.0	43.269	832	640	56	56	80	640x480 85Hz
	V	-		85.0	509	480	1	3	25	
6	H	+	40.0	37.879	1056	800	40	128	88	800x600 60Hz
	V	+		60.317	628	600	1	4	23	
7	H	+	49.5	46.875	1056	800	16	80	160	800x600 75Hz
	V	+		75.0	625	600	1	3	21	
8	H	+	56.25	53.674	1048	800	32	64	152	800x600 85Hz
	V	+		85.061	631	600	1	3	27	
9	H	+/-	57.283	49.725	1152	832	32	64	224	832x624 75Hz
	V	+/-		74.55	667	624	1	3	39	
10	H	-	65.0	48.363	1344	1024	24	136	160	1024x768 60Hz
	V	-		60.0	806	768	3	6	29	
11	H	-	78.75	60.123	1312	1024	16	96	176	1024x768 75Hz
	V	-		75.029	800	768	1	3	28	
12	H	+	94.5	68.677	1376	1024	48	96	208	1024x768 85Hz
	V	+		84.997	808	768	1	3	36	
13	H	+/-	100.0	68.681	1456	1152	32	128	144	1152x870 75Hz
	V	+/-		75.062	915	870	3	3	39	
14	H	+/-	92.978	61.805	1504	1125	18	134	200	1152x900 65Hz
	V	+/-		65.96	937	900	2	4	31	
15	H	+	108.0	63.981	1688	1280	48	112	248	1280x1024 60Hz
	V	+		60.02	1066	1024	1	3	38	
16	H	+	135.0	79.976	1688	1280	16	144	248	1280x1024 75Hz
	V	+		75.035	1066	1024	1	3	38	

OPERATING INSTRUCTIONS

FRONT VIEW



Front Control Panel

REAR VIEW

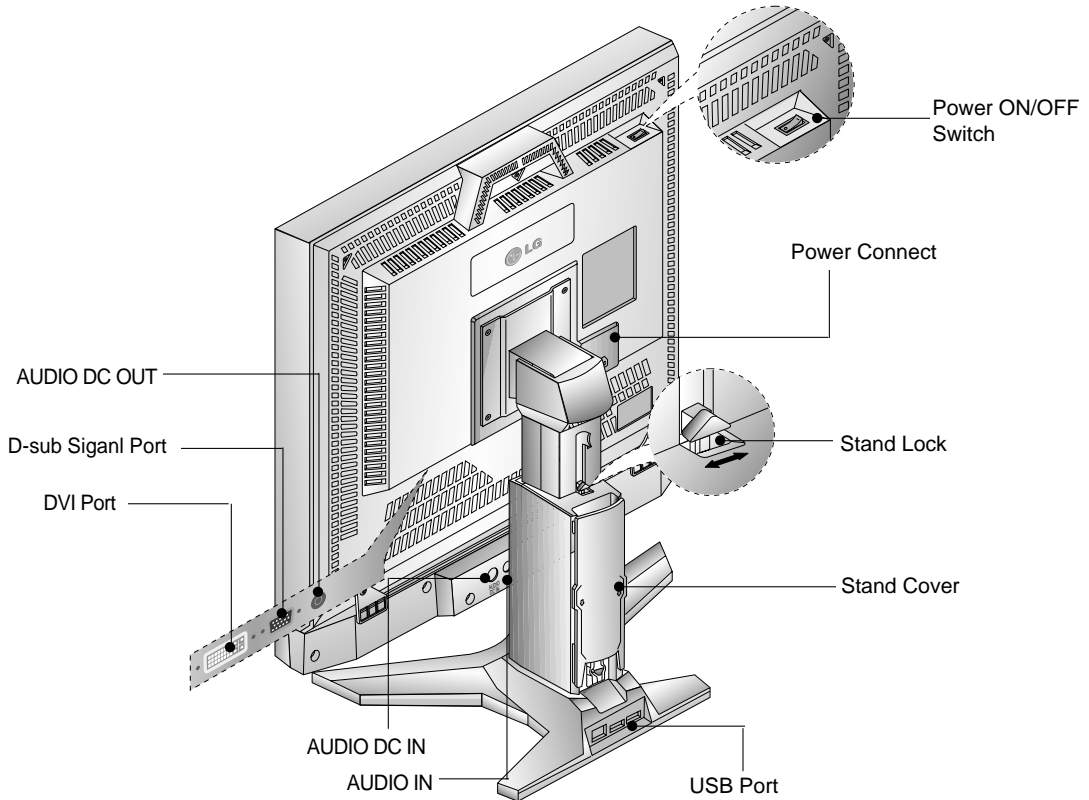

Front Control Panel

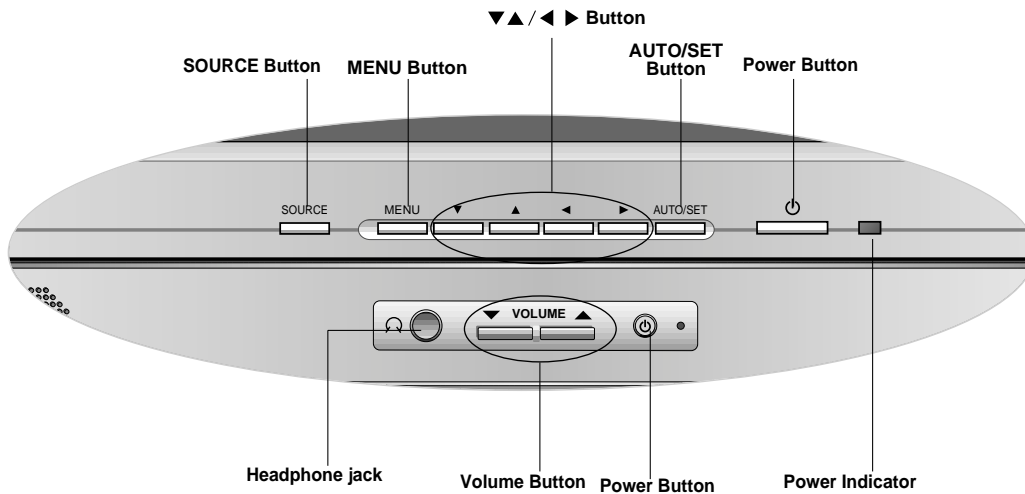

Control

Function



SOURCE Button

Use this button to make Dsub or DVI connector active. This feature is used when two computers are connected to the monitor. The default setting is Dsub.



MENU Button

Use this button to enter or exit the on screen display.



<v></v>/<v></v> Button

Use these buttons to choose or adjust items in the on screen display.

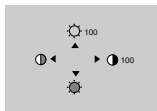

<Shortcut Keys>

- Brightness and Contrast can be adjusted directly without entering the On Screen Display (OSD) system. Touch the <v></v>/<v></v> buttons to adjust the settings and then the OSD button to save all changes. The Brightness and Contrast functions are also available in the On Screen Display (OSD) menu.



AUTO/SET Button

Use this button to enter a selection in the on screen display.

* AUTO adjustment function

TO the **AUTO/SET** button before using OSD menu.

This button is for the automatic adjustment of the screen position, clock and phase.

Note: Some signal from some graphics boards may not function properly. **If the results are unsatisfactory**, adjust your monitor's Position, Clock and Phase manually.



Power Button

Use this button to turn the monitor on or off.



Power Indicator

This indicator lights up green when the monitor operates normally. If the monitor is in DPM (Energy Saving) mode (stand-by/ suspend/power off), this indicator color changes to amber.

Control

Function

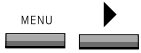

MENU, ► Button

Press and hold the MENU button and ► button for 3 seconds: the message “CONTROLS LOCKED” appears.



You can unlock the OSD controls at any time by pushing the MENU, ► button for 3 seconds: the message “CONTROLS UNLOCKED” will appear.



Headphone jack

Headphone jack that automatically mutes the speaker volume is attached.



Volume Buttons

Used to adjust volume.



Power Button

Use to turn ON/OFF audio.

Pivot Function

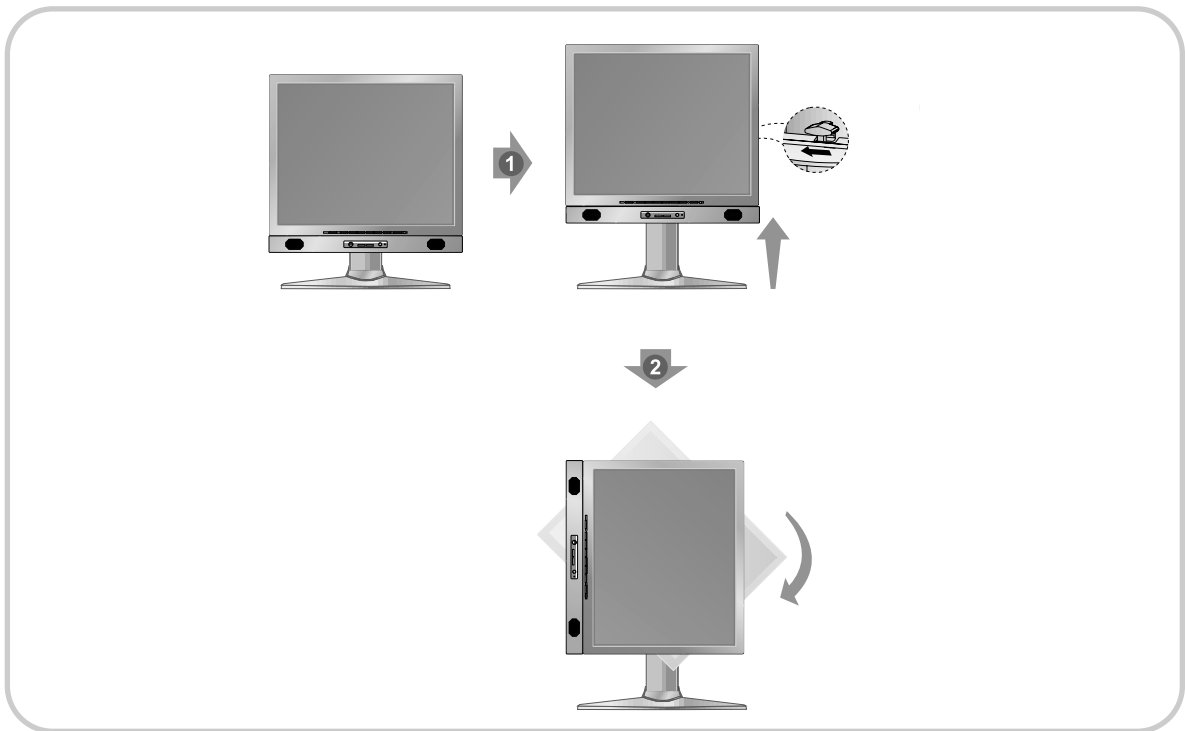

You can adjust the height of the screen and also rotate it 90° clockwise.

Making use of USB (Universal Serial Bus)*

USB (Universal Serial Bus) is an innovation in connecting your different desktop peripherals conveniently to your computer. By using the USB, you will be able to connect your mouse, keyboard, and other peripheral to your monitor instead of having to connect them to your computer. This will give you greater flexibility in setting up your system. USB allows you to connect chain up to 120 devices on a single USB port, and you can “hot” plug (attach them while the computer is running) or unplug them while maintaining Plug and Play auto detection and configuration. This monitor has an integrated BUS-powered USB hub, allowing up to 2 other USB devices to be attached it.

USB connection

1. Connect the upstream port of the monitor to the downstream port of the USB compliant PC or another hub using the USB cable. (Computer must have a USB port)
2. Connect the USB compliant peripherals to the downstream ports of the monitor.

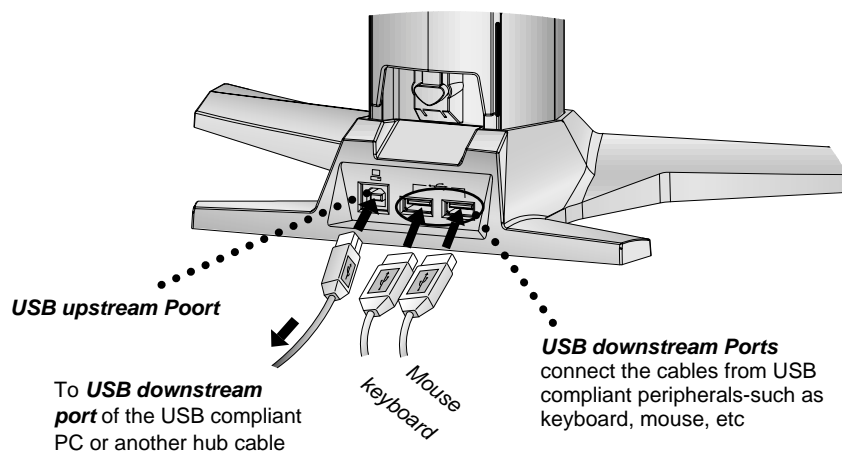

NOTE

- To activate the USB hub function, the monitor must be connected to a USB compliant PC(OS) or another hub with the USB cable(enclosed).
- When connecting the USB cable, check that the shape of the connector at the cable side matches the shape at the connecting side.
- Even if the monitor is in a power saving mode, USB compliant devices will function when they are connected the USB ports(both the upstream and downstream) of the monitor.

IMPORTANT: These USB connectors are not designed for use with high-power USB devices such as a video camera, scanner, etc. LGE recommends connecting high-power USB devices directly to the computer

WIRING DIAGRAM

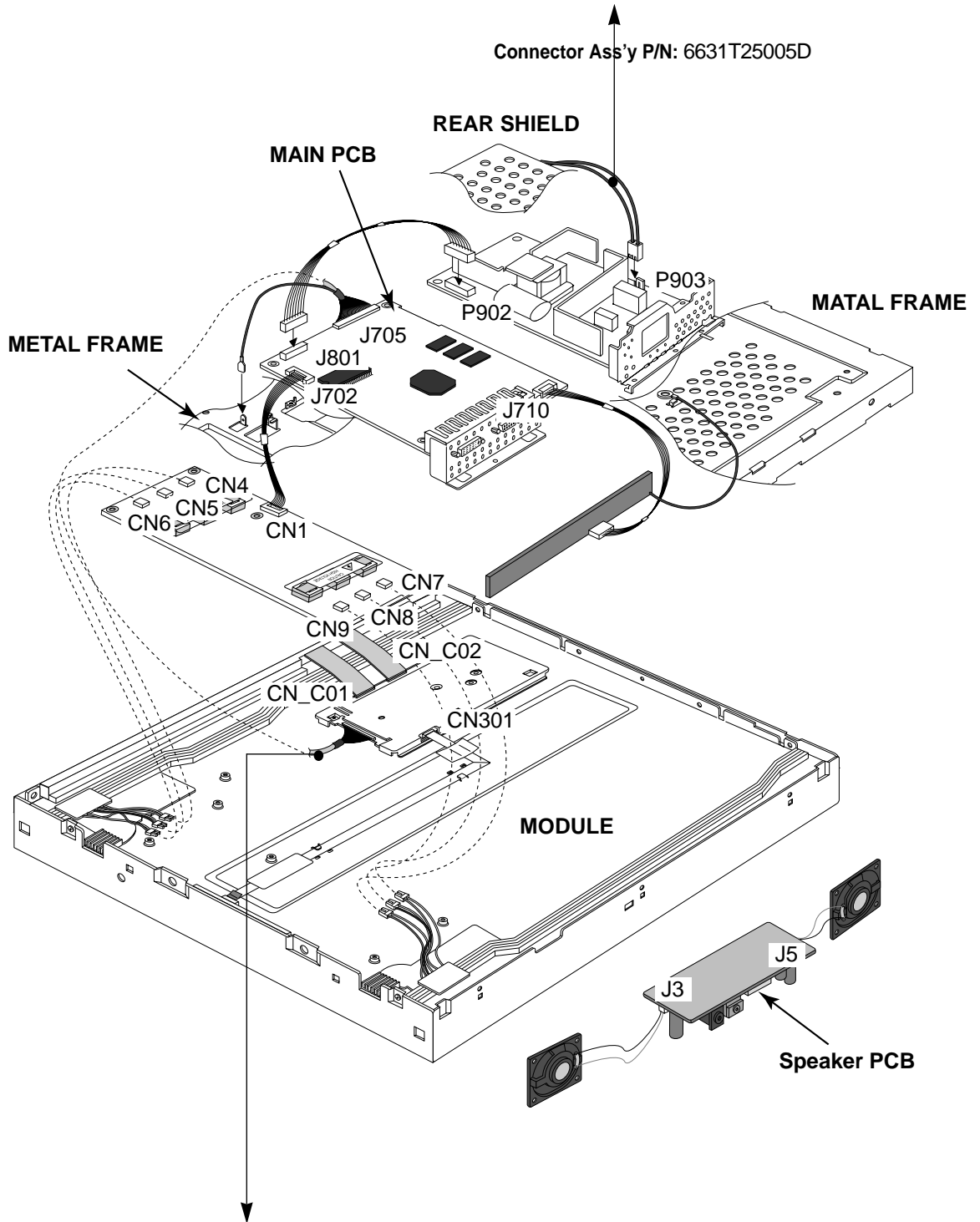

Connector Ass'y P/N: 6631T11012P

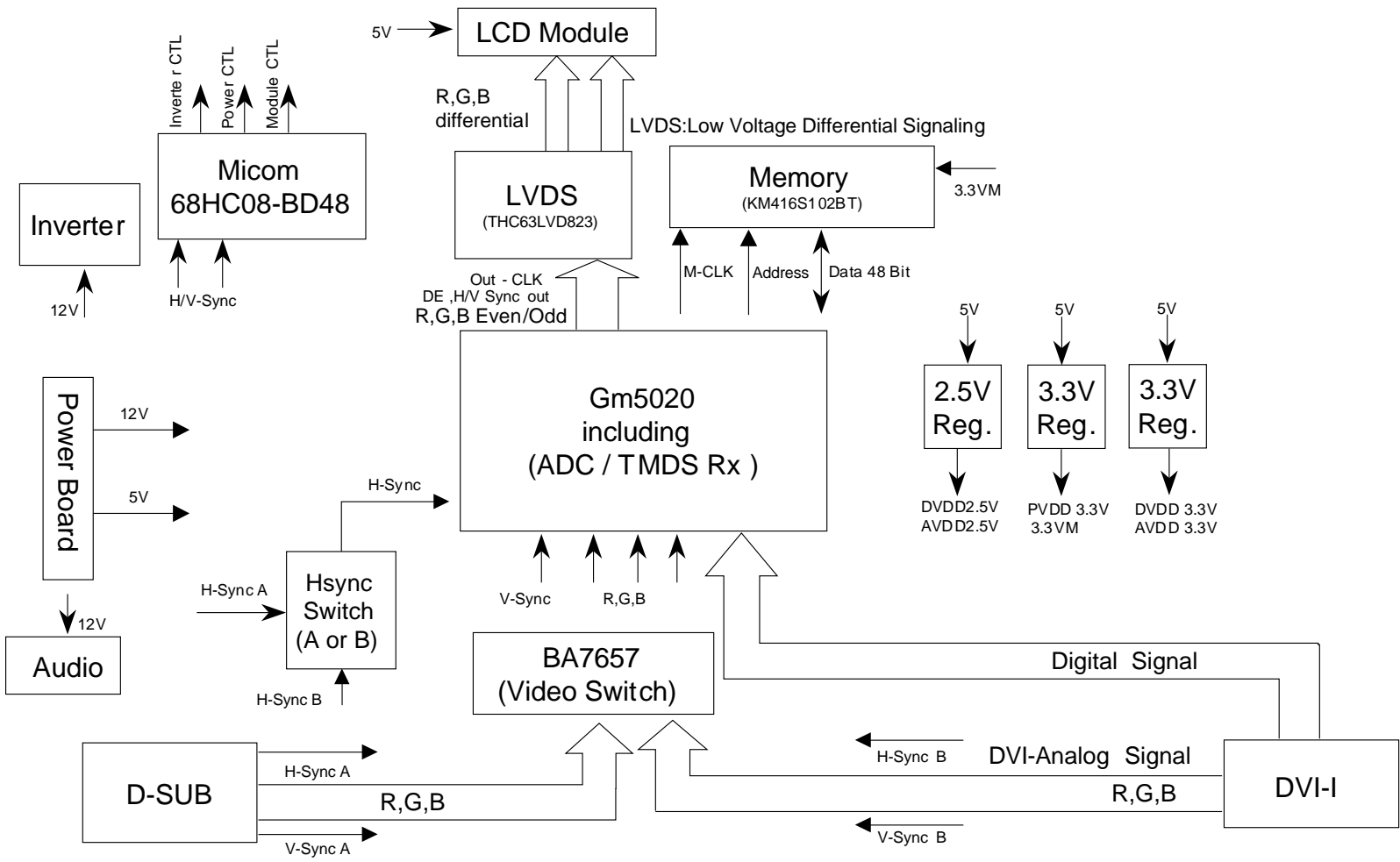

DESCRIPTION OF BLOCK DIAGRAM

1. Input signal switching part(BA7657).

There are two analog inputs which are D-Sub analog and DVI-analog input. They come from each 15 pin D-Sub and 29 pin DVI-I connector.

2. Video Controller Part(GM5020).

This part amplifies the level of video signal for the analog to digital conversion and converts from the analog video signal to the digital video signal using a pixelclock.

The pixel clock for each mode is generated by the PLL.

The range of the pixel clock is from 25MHz to 135MHz.

This part consists of the Scaler and frame buffers which converts frame rate of input signal to 60Hz frame rate.

The Scaler gets the video signal converted analog to digital, interpolates input to 1280 X 1024 resolution signal and outputs 8-bit R, G, B signal to transmitter.

Especially pre-amp / ADC / Video controller are merged to one chip 'Gm5020' by Genesis.

Also FRC is separate.

3. Display Data Transmitter Part(LVDS).

This part transmit digital signal from the Scaler to the receiver of module.

4. Power Part.

This part consists of the one 5V, two 3.3V and one 2.5 regulators to convert power which is provided 12V, 5V in Power Board.

12V is provided for inverter, 5V is provided for Micom and LCD Panel.

Also, 5V is converted 3.3V and 2.5V by regulator. Converted power is provided for IC in the main board.

5. MICOM Part.

This part consists of EEPROM IC which stores control data, Reset IC and the Micom.

The Micom distinguishes polarity and frequency of the H/V sync are supplied from signal cable.

The controlled data of each modes is stored in EEPROM.

6. Inverter

The inverter converts from DC12V to AC 700Vrms and operate back-light lamp of module.

7. Audio Part

Input voltage is DC12V from Main board Audio Signal AC 700Vrms is amplified.

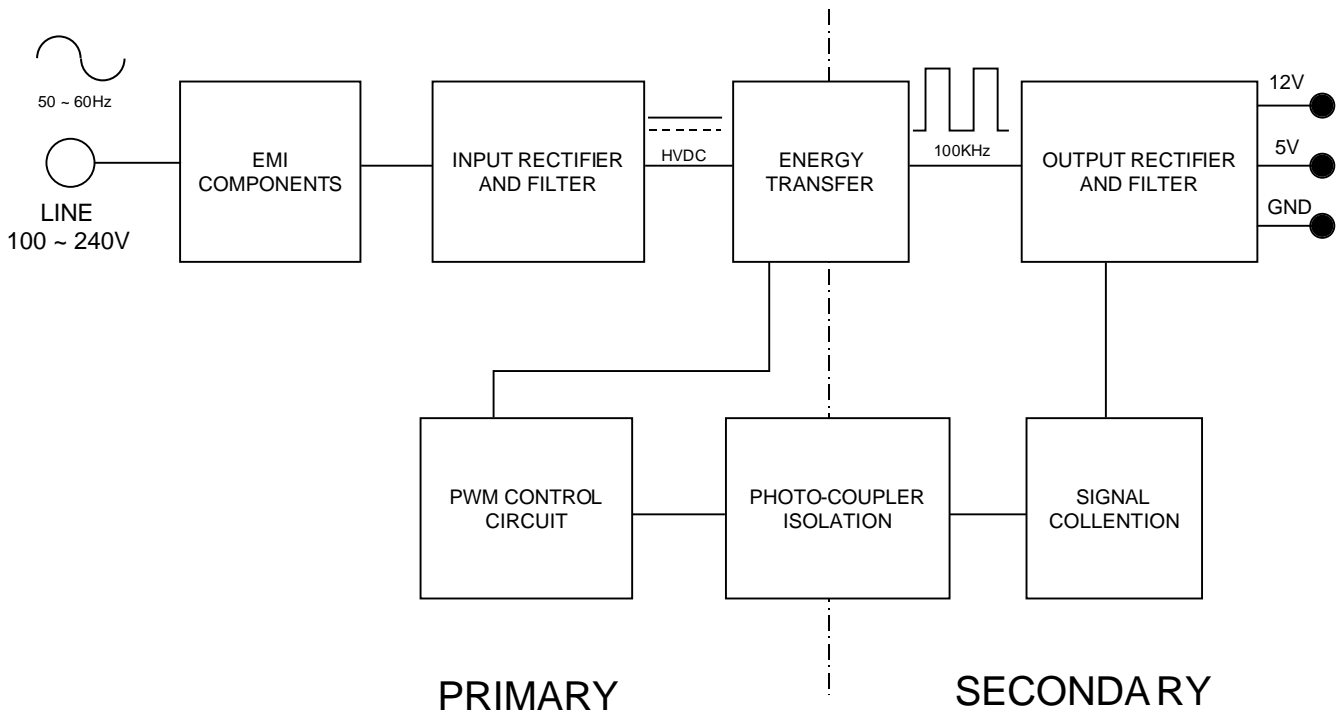

Operation description_Power

1. EMI components.

This part contains of EMI components to comply with global marketing EMI standards like FCC, VCCI CISPR, the circuit included a line-filter, across line capacitor and of course the primary protection fuse.

2. Input rectifier and filter.

This part function is for transfer the input AC voltage to a DC voltage through a bridge rectifier and a bulk capacitor.

3. Energy Transfer.

This part function is transfer the primary energy to secondary through a power transformer.

4. Output rectifier and filter.

This part function is to make a pulse width modulation control and to provide the driver signal to power switch, to adjust the duty cycle during different AC input and output loading condition to achive the dc output stablize, and also the over power protection is also monitor by this part.

5. Photo-Coupler isolation.

This part function is to feed back the dc output changing status through a photo transistor to primary controller to achive the stablized dc output voltage.

6. Signal collection.

This part function is to collect the any change from the dc output and feed back to the primary through photo transistor

ADJUSTMENT

All adjustment are thoroughly checked and corrected when the monitor leaves the factory, but sometimes several minor adjustment may be required. Adjustment should be following procedure and after warming up for a minimum of 10 minutes.

• Alignment appliances and tools.

- IBM compatible PC
- Programmable Signal Generator.
(eg. VG-819 made by Astrodesign Co.)
- E(E)PROM with each mode data saved.

1. Adjustment Start

- 1) Display any pattern at any Mode.
- 2) Run alignment program for LB886F on the IBM compatible PC.
- 3) Select EEPROM → ALL INIT command and Enter
- 4) This will make all data to default state
- 5) Select COMMAND → PRESET START command and Enter

2. Adjustment for Factory Preset Mode

- 1) Select DIST. ADJ → FOS DEFAULT command and Enter
- 2) It will copy all factory default data to EEPROM automatically.

3. Adjustment for White Balance

- 1) Display color 0,0 pattern at Mode 15.
- 2) Set External Bright to MAX position and Contrast to MAX Position.
- 3) Select PRESET START → BIAS CAL command and Enter.
- 4) No attempt to manually adjust, BIAS data is automatically adjusted and saved to the EEPROM.
- 5) Display color 15,0 pattern at Mode 15.
- 6) Select DRIVE CAL command and Enter.
- 7) 5800K and 9300K are automatically adjusted and saved to the EEPROM.
- 8) Select PRESET EXIT command and Enter.

4. Adjustment for EDID

- 1) Use this procedure only when there is some problem on EDID data.
- 2) Connect the D-sub cable.
- 3) Select EEPROM → EDID Write command and Enter.
- 4) Select DDC(A) Write command and Enter.
- 5) Connect the DVI-I cable.
- 6) Select DDC(D) Write command and Enter.

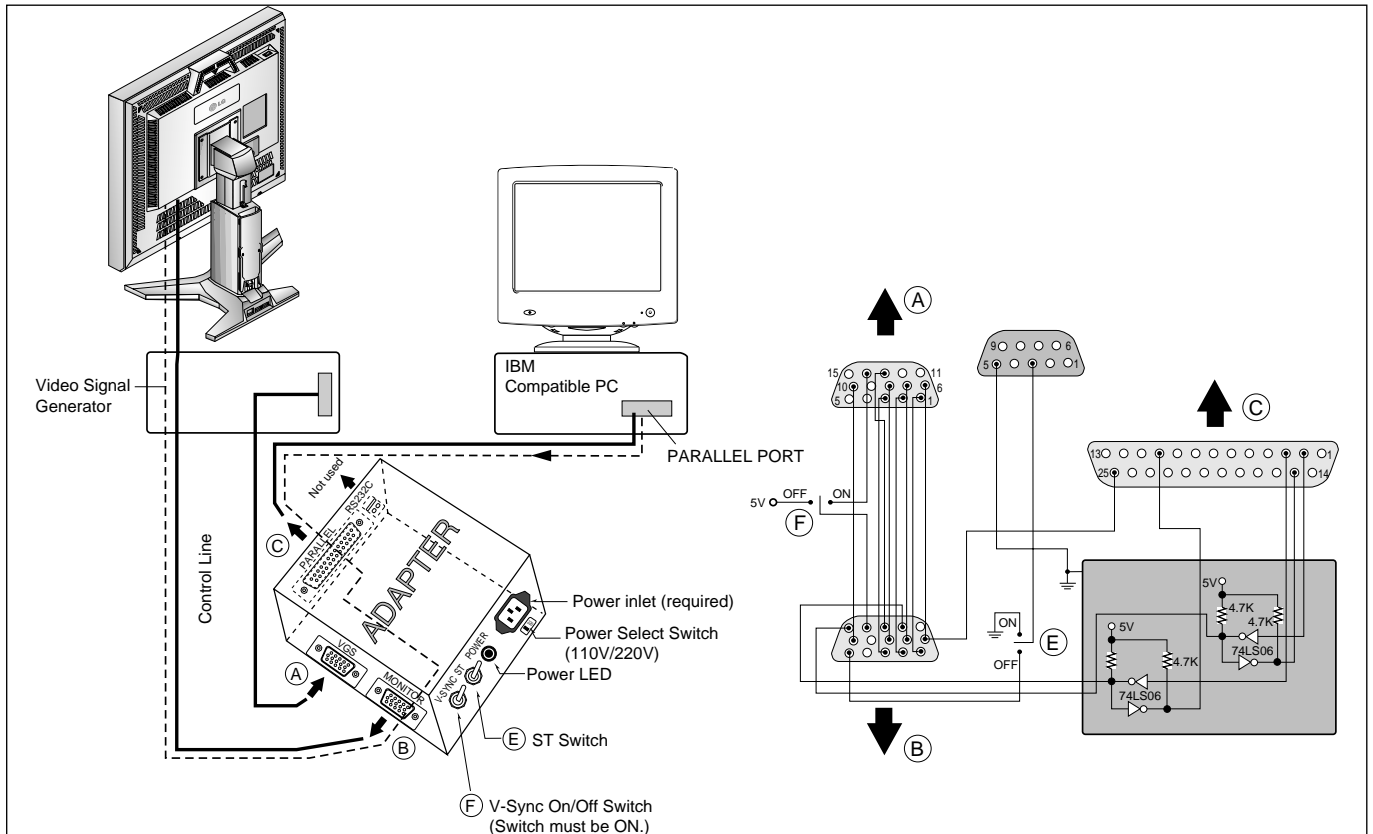
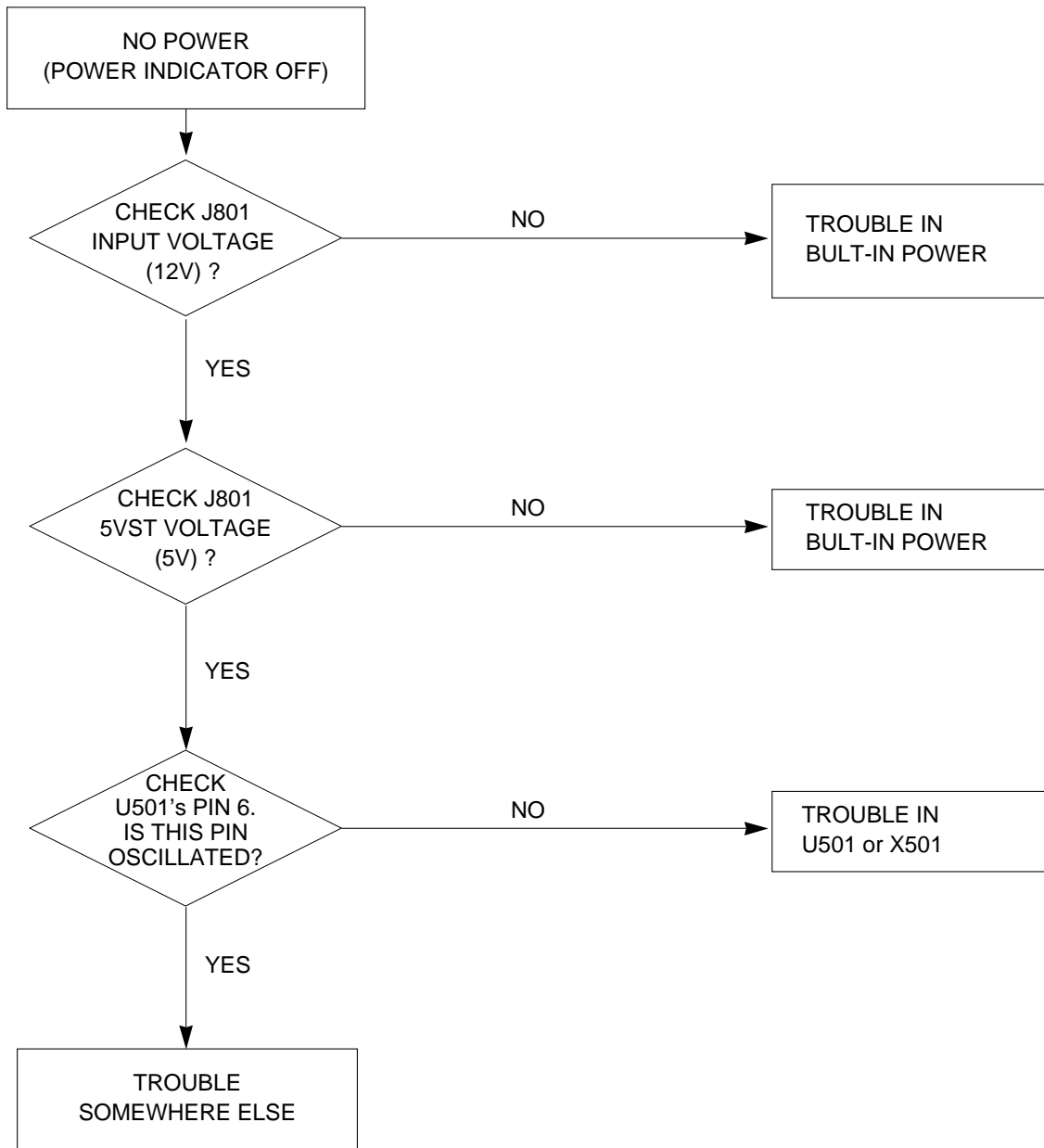

Figure 1. Cable Connection

TROUBLESHOOTING GUIDE

1. NO POWER



2. NO RASTER

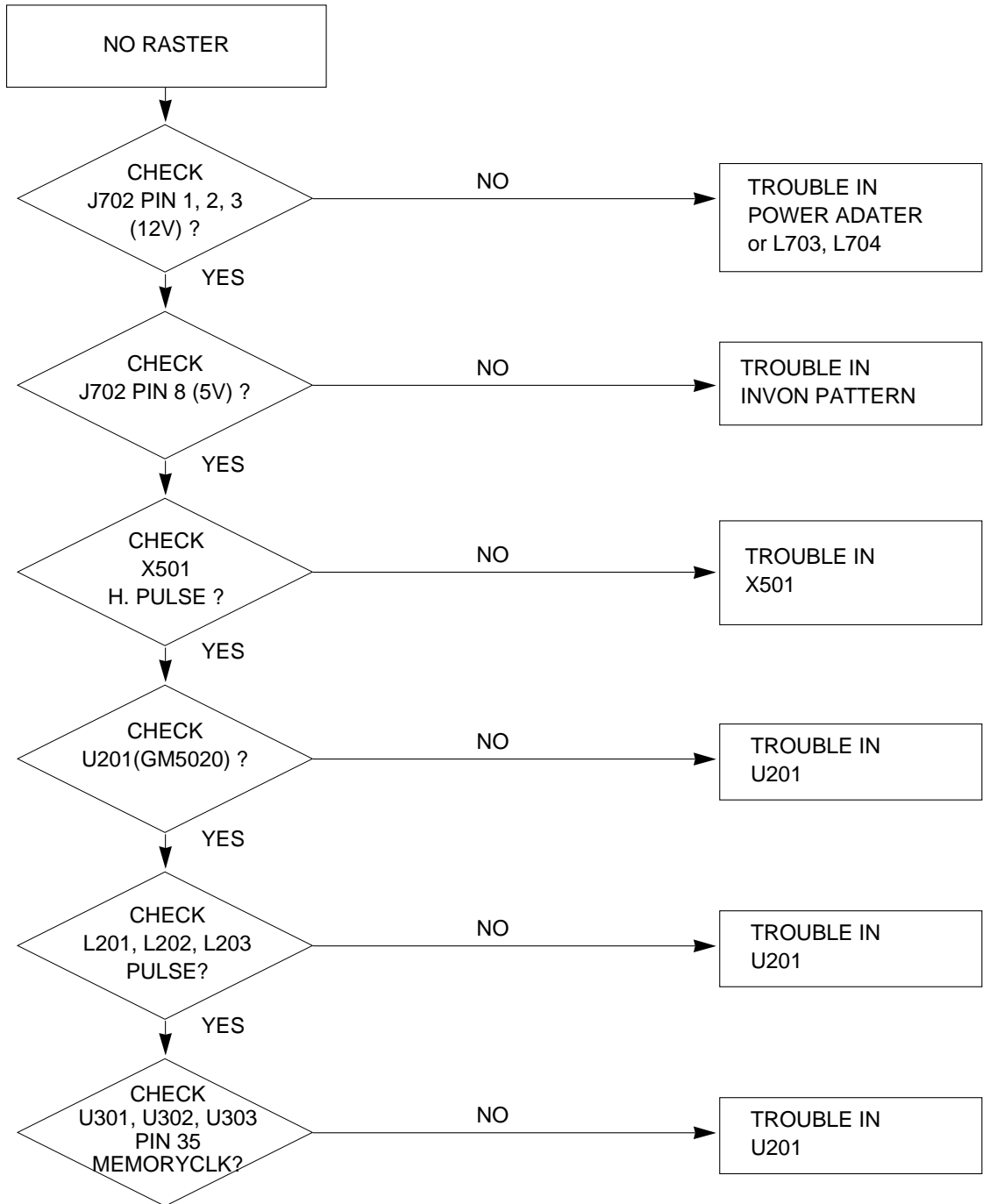

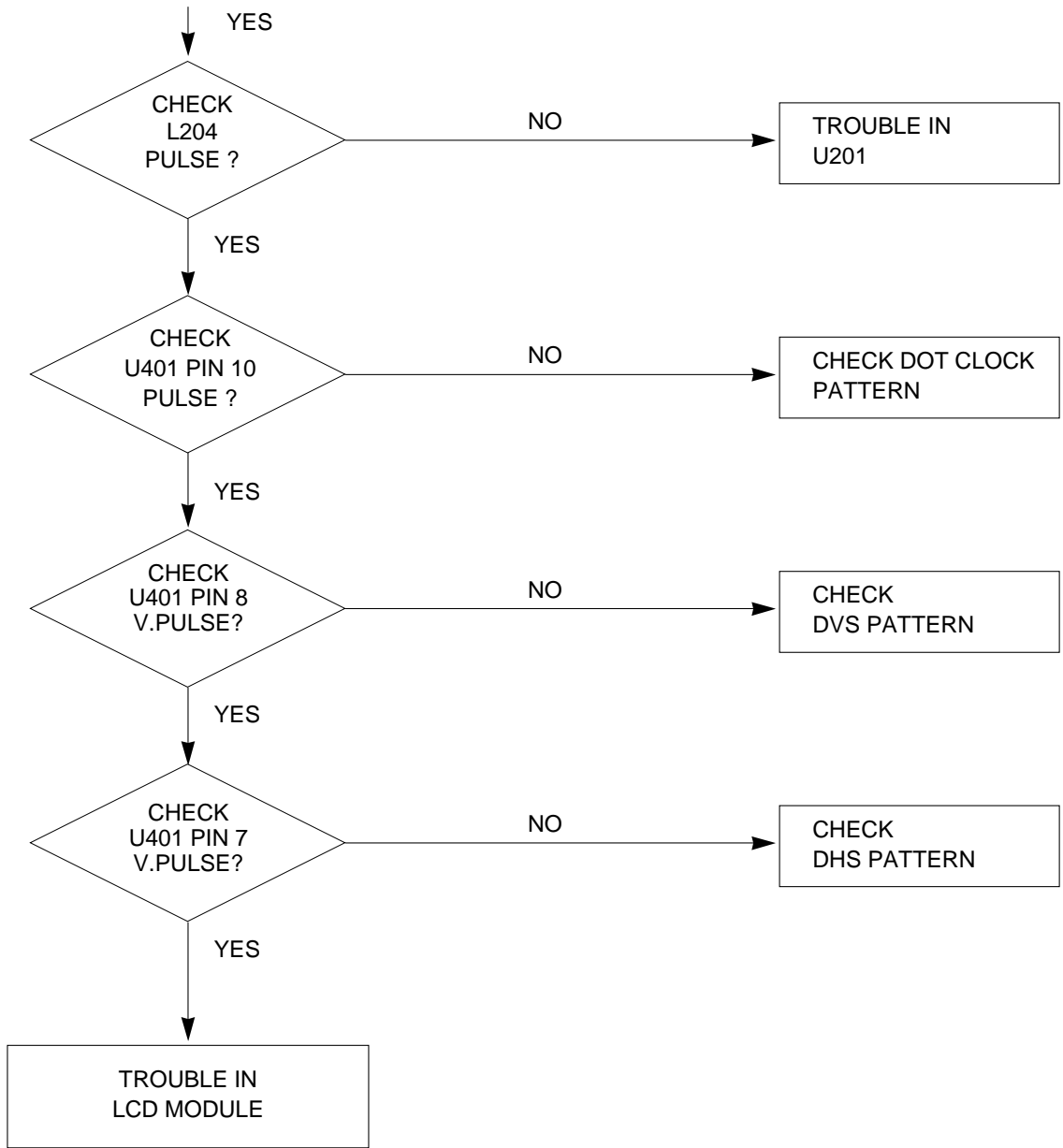

3. NO CLOCK (CLOCK GENERATOR)

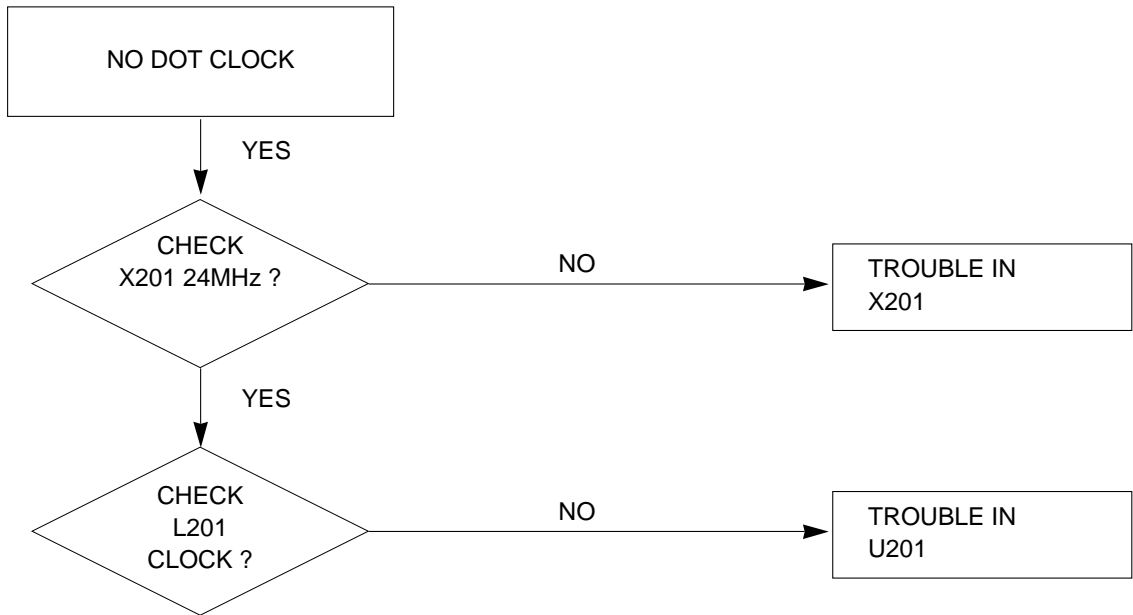

4. TROUBLE IN DPM

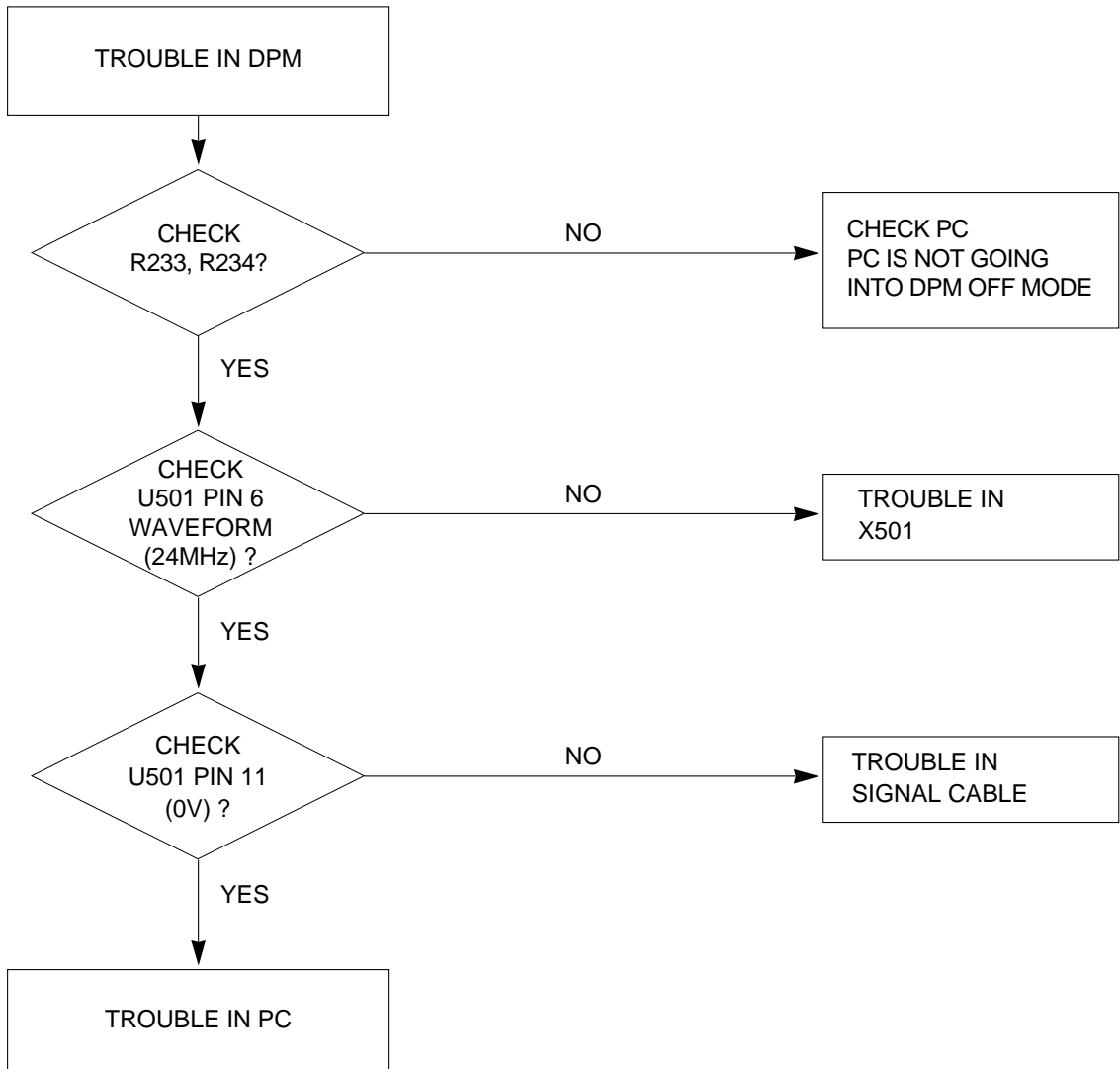

5. AUDIO NO POWER

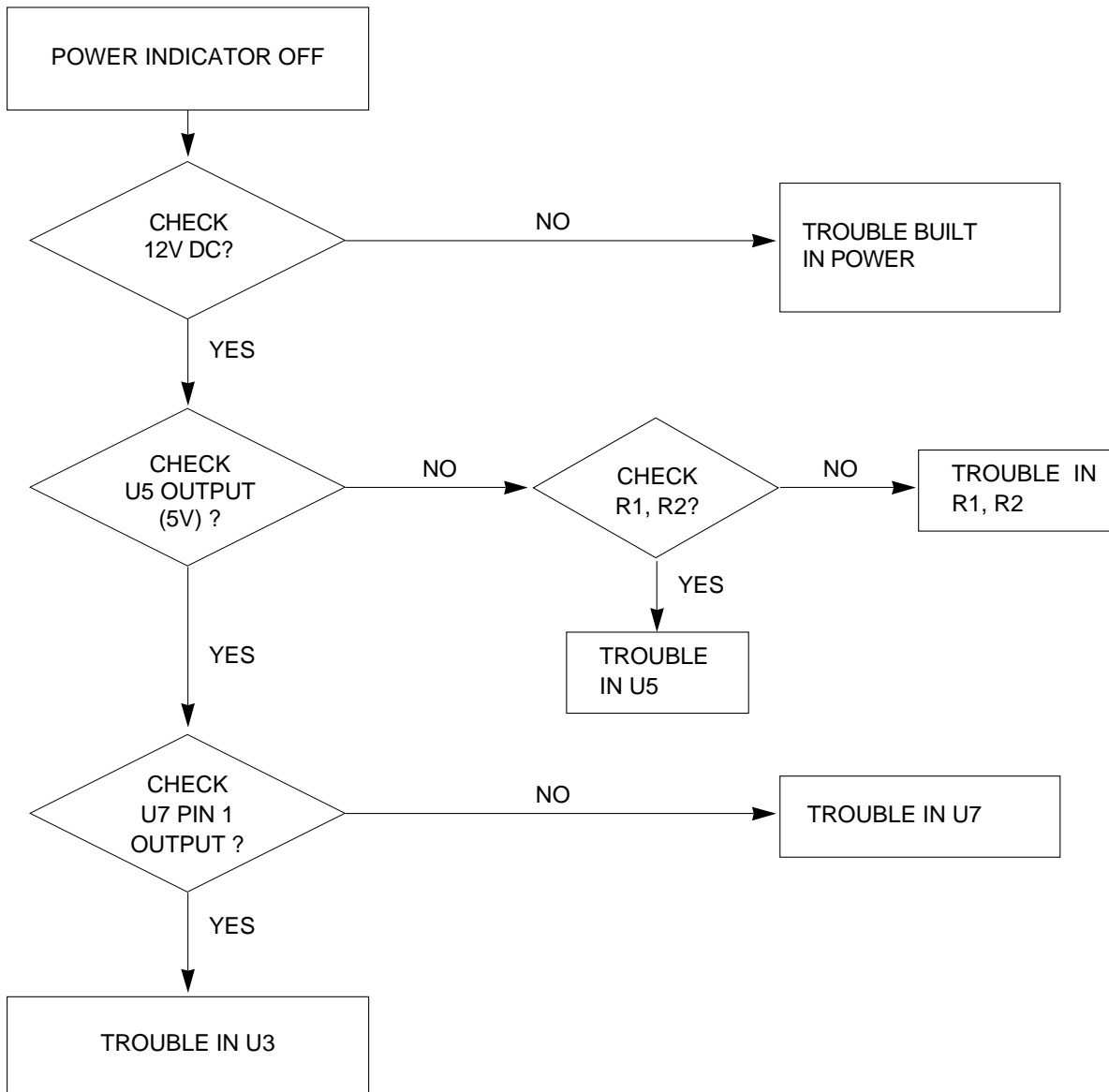

6. NO VOLUME CONTROL

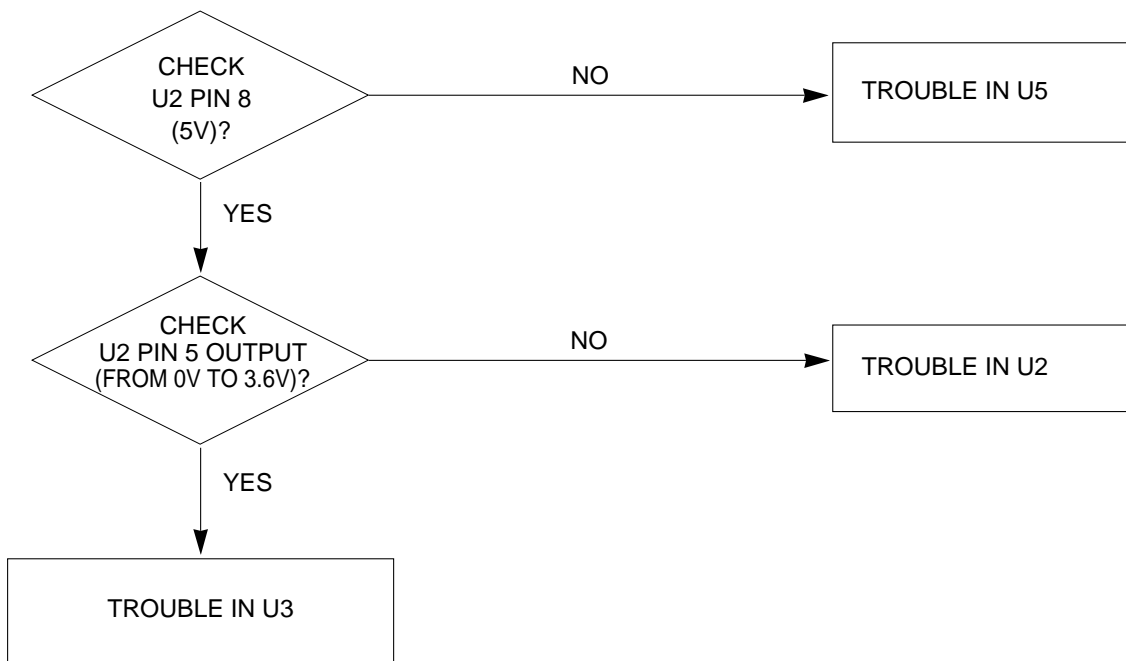

7. AUDIO NO OUTPUT

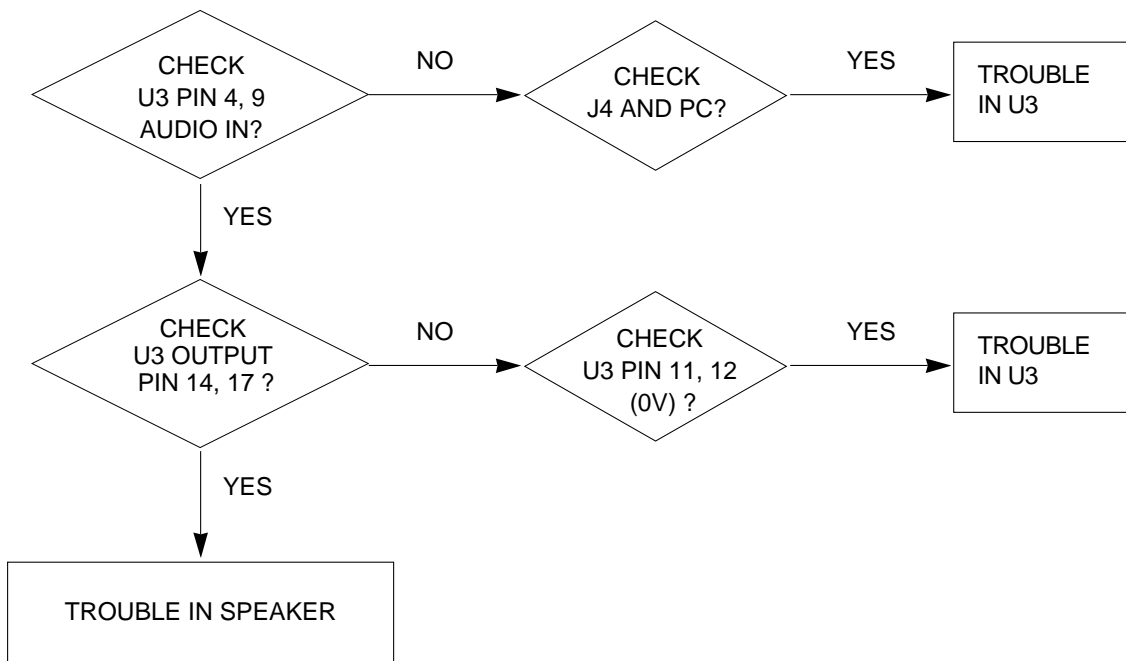

1. MAIN BOARD (Component Side)

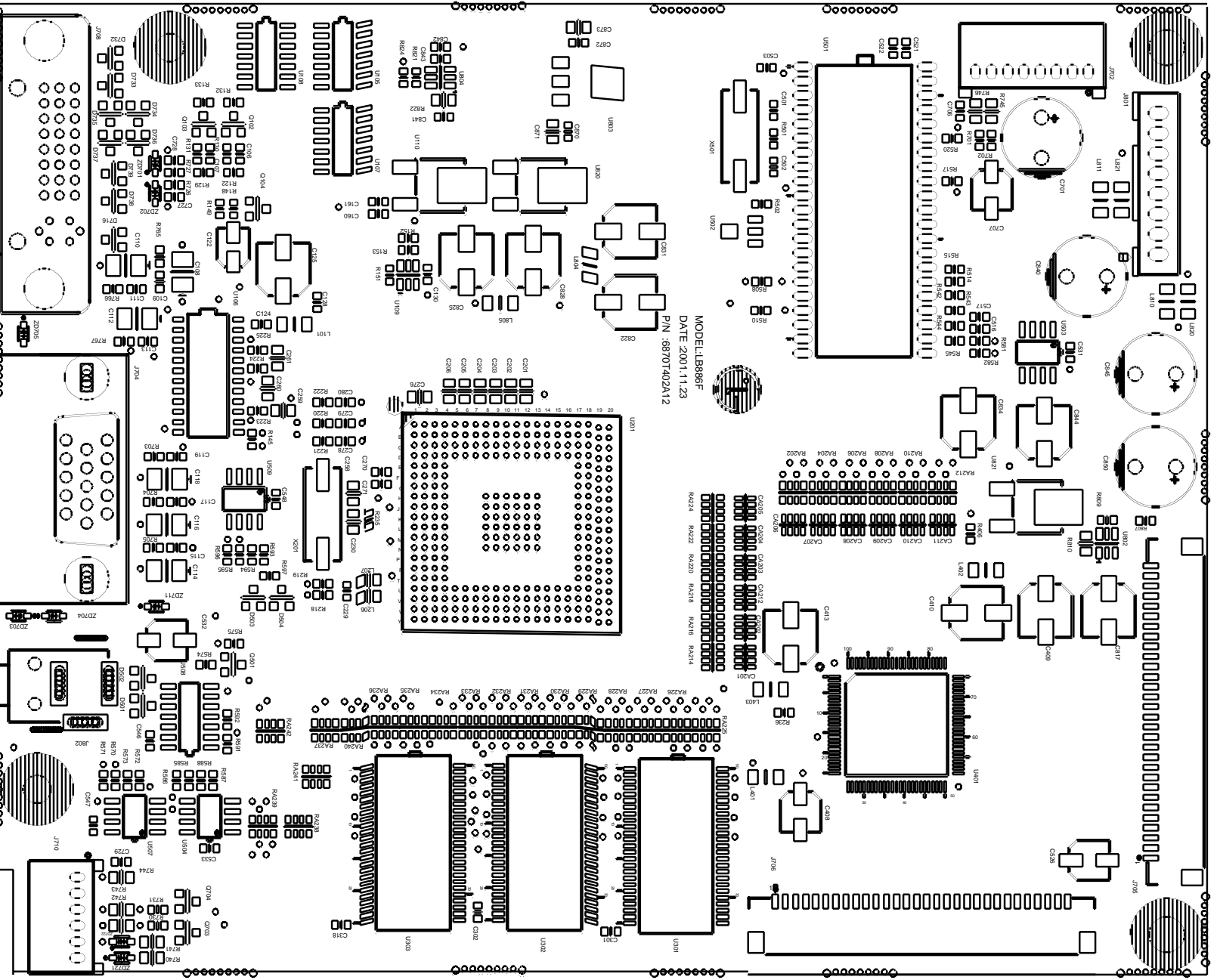

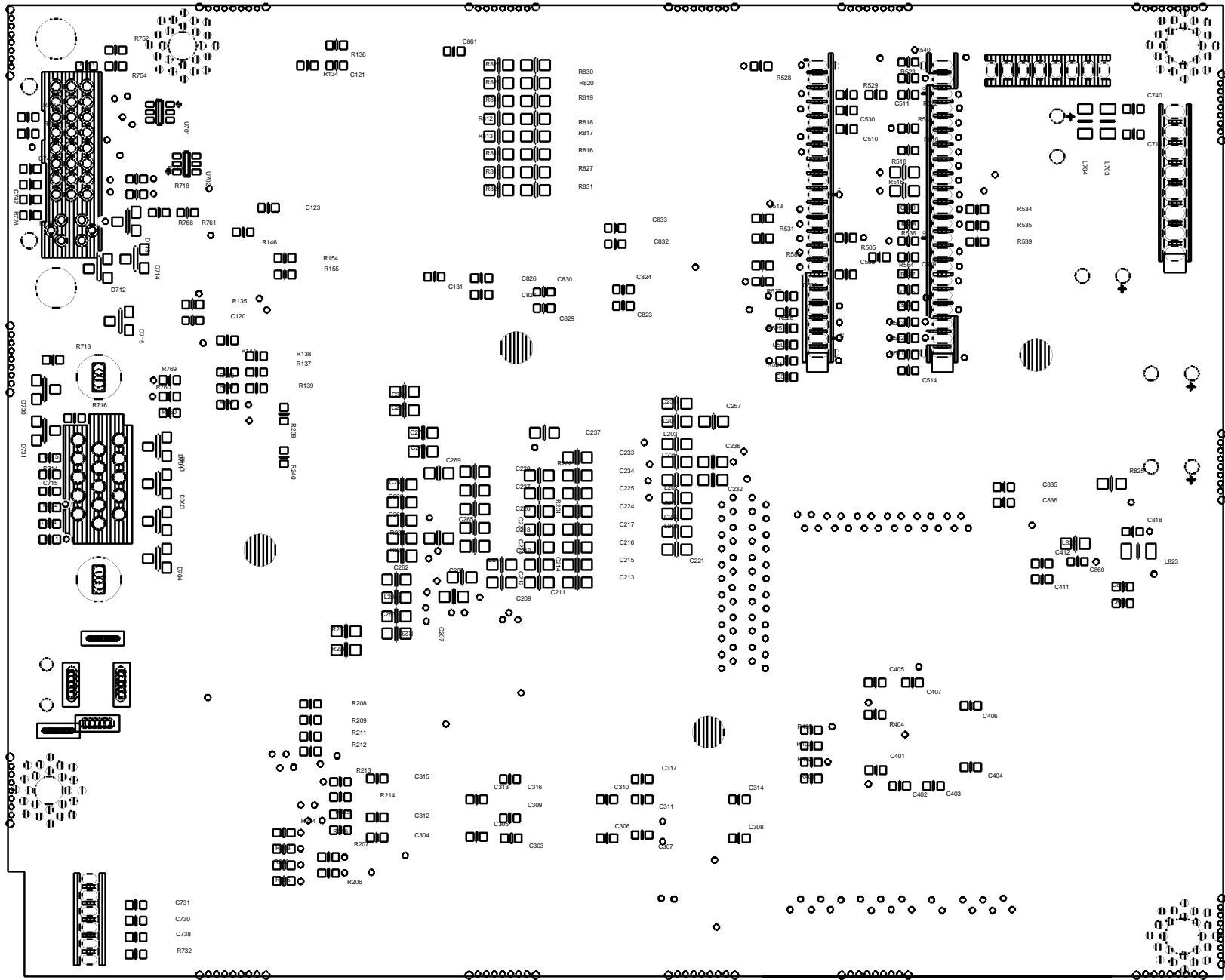

3. POWER BOARD (Component Side)

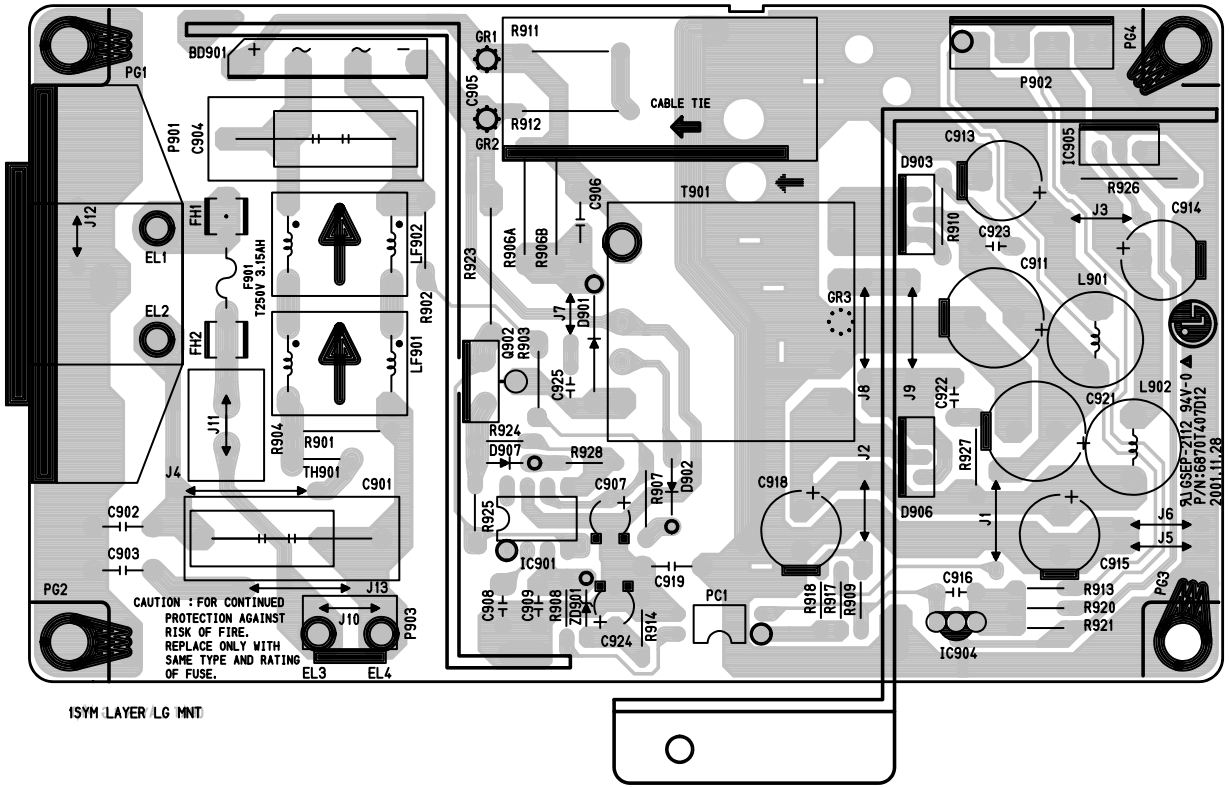

4. POWER BOARD (Solder Side)

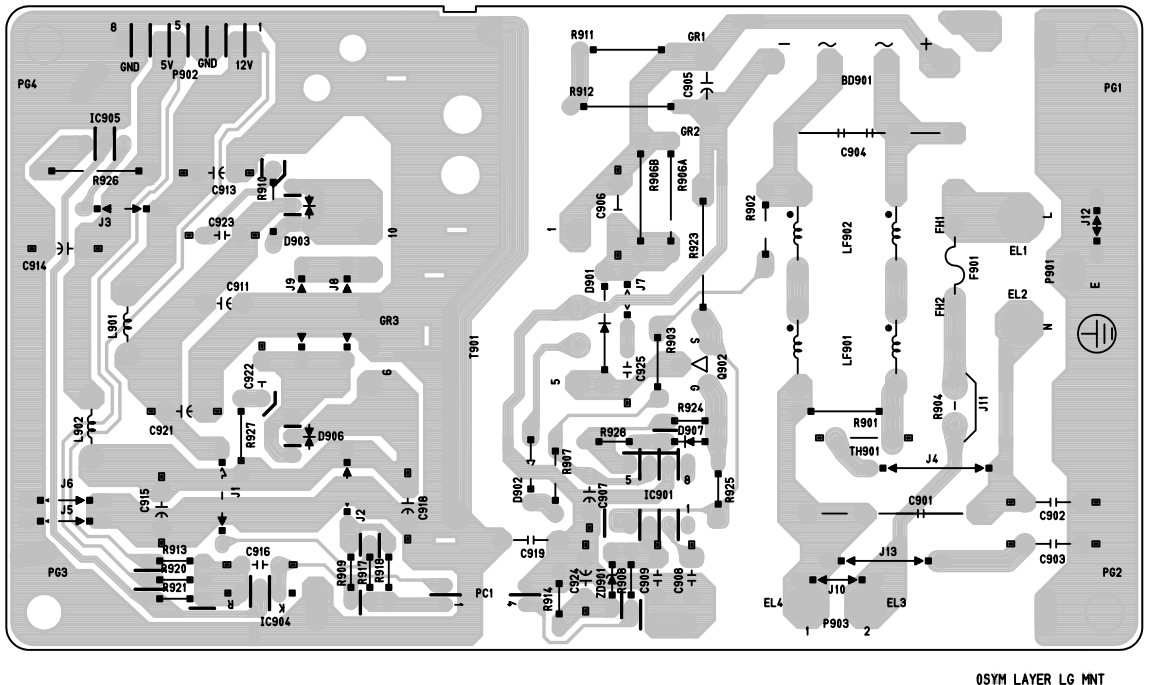

5. CONTROL BOARD

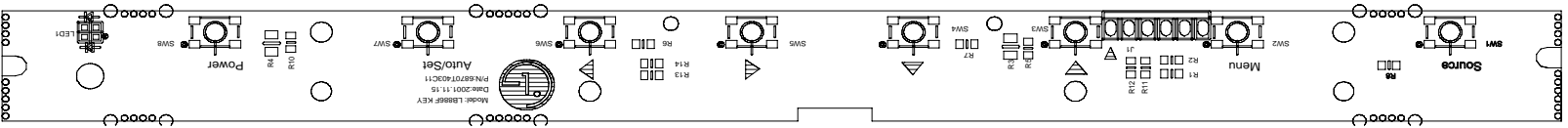

6. USB BOARD

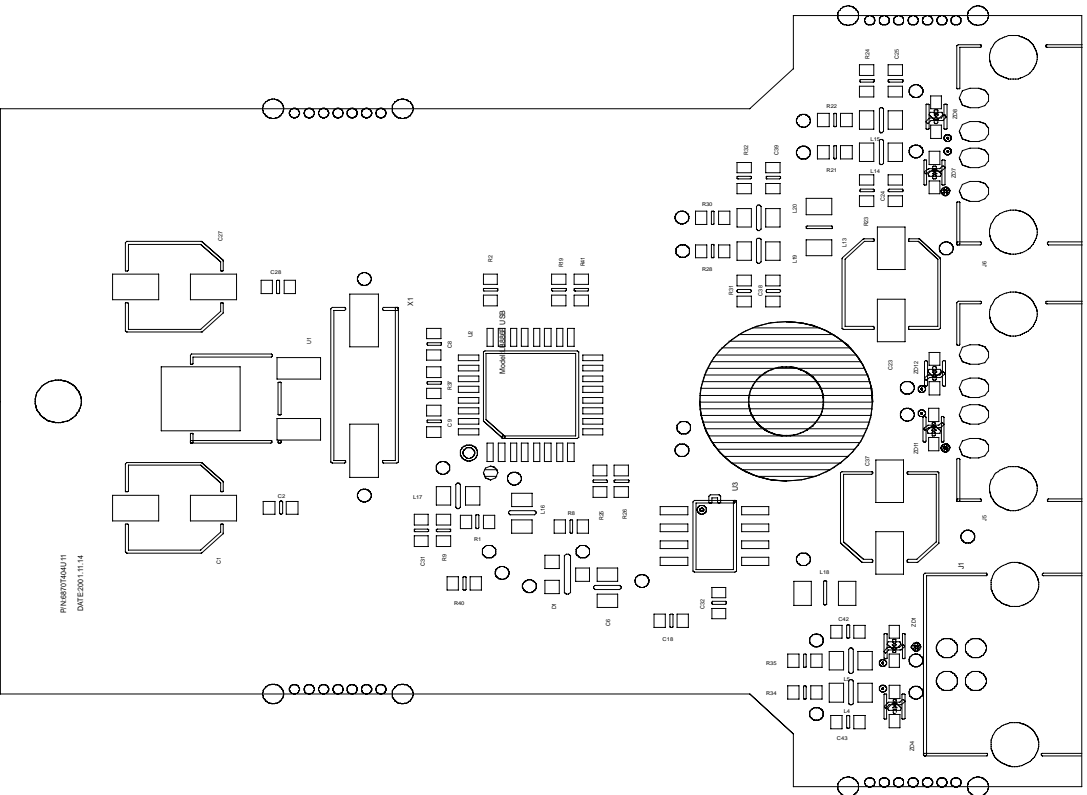

7. SPEAKER BOARD (Component Side)

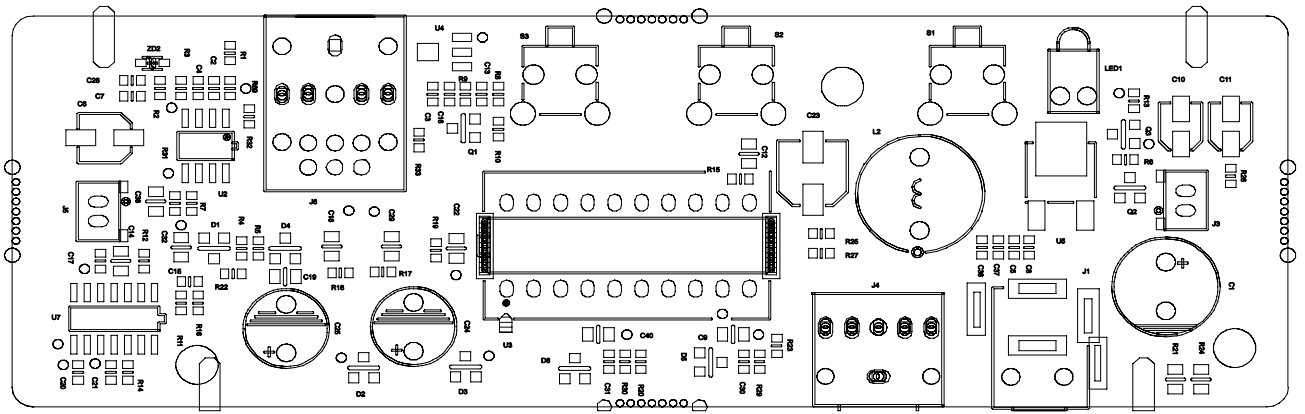

8. SPEAKER BOARD (Solder Side)

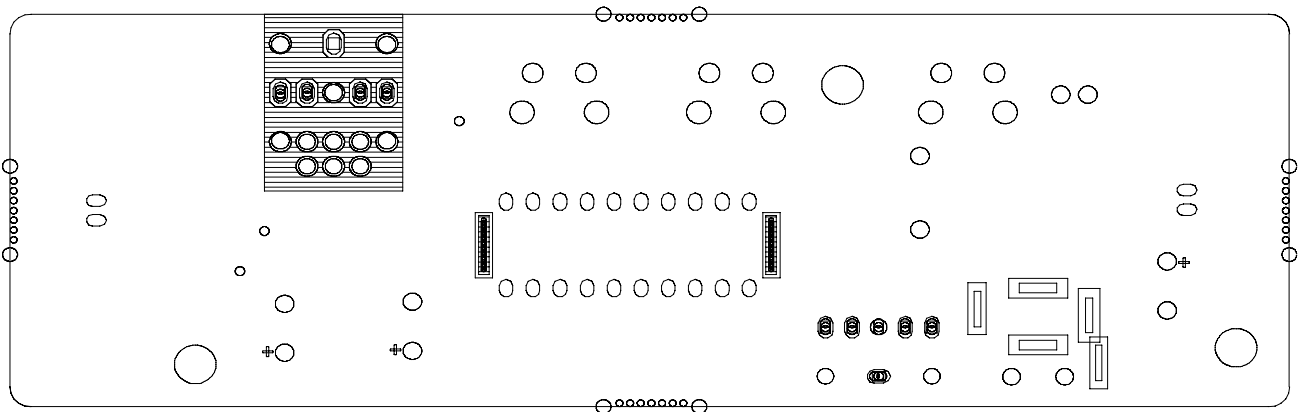

EXPLODED VIEW

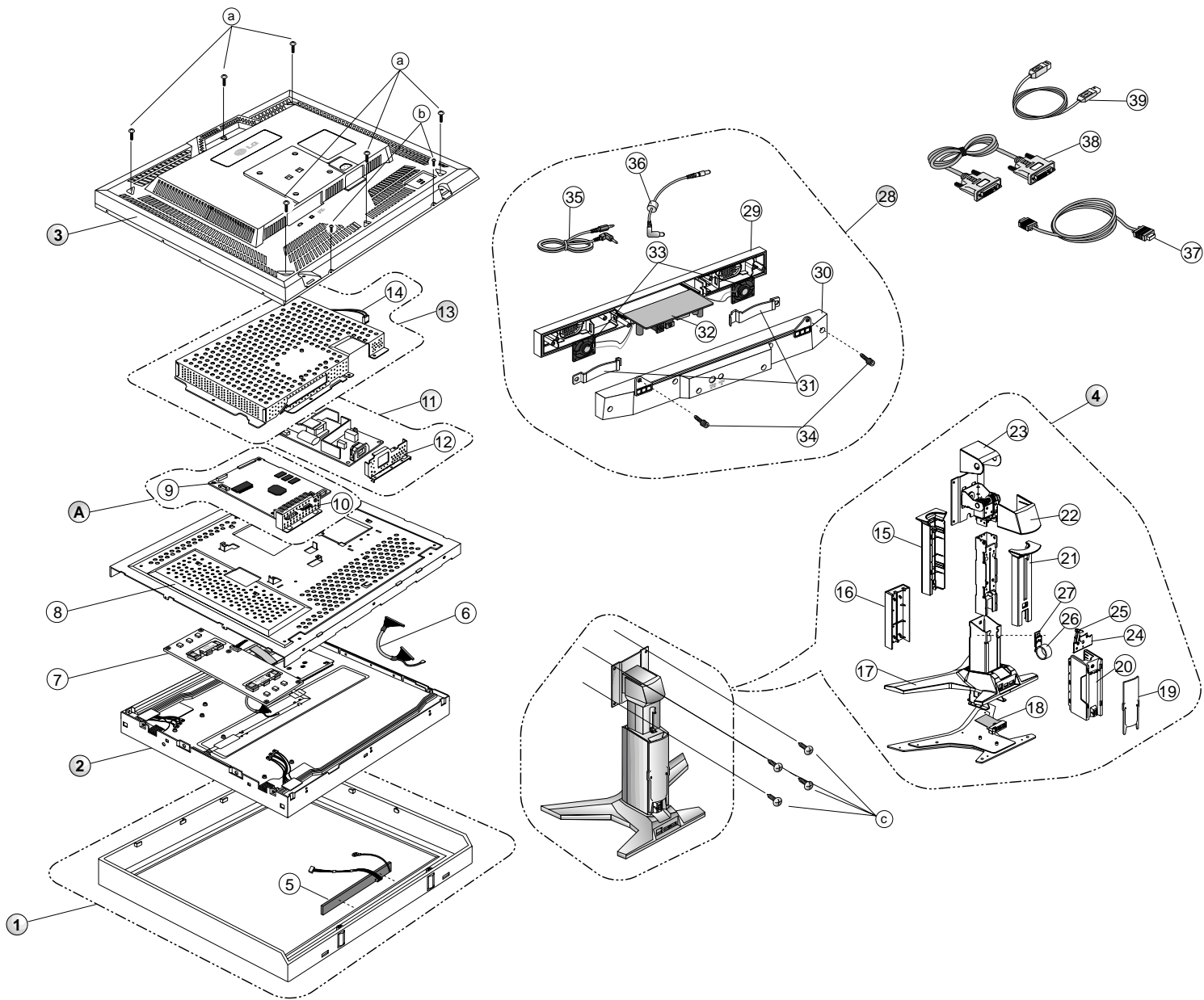

EXPLODED VIEW PARTS LIST

* Note: Safety mark 

Ref. No.	Part No.	Description
1	3091TKL032C	 CABINET ASSEMBLY, LB886F BRAND - SPK
2	6304FLP023A	LCD(LIQUID CRYSTAL DISPLAY), "LM181E05-C4M1 LG PHILPS TFT COLOR 18.1" SXGA
3	3809TKL022D	 BACK COVER ASSEMBLY, LB886F . EQ22 COLOR
4	3043TKK086B	TILT SWIVEL ASSEMBLY , LB886F, HIPS-60HR
5	6871TST273A	PWB(PCB) ASSEMBLY, SUB, LB886F CONTROL TOTAL BRAND CL-29
6	6631T11012P	CONNECTOR ASSEMBLY, 30P H-H 100MM UL20276 PANEL LINK LB886F
7	6633TZA008B	 INVERTER ASSEMBLY, ALPS KUBNKM030A 6-LAMP LB886F/LI884E
8	4951TKS078B	METAL ASSEMBLY, FRAME MAIN - LB886F
9	6871TMT275B	PWB(PCB) ASSEMBLY,MAIN, LB886F ALLGS BRAND CL-29 TOTAL
10	4814TKK188A	SHIELD, INTERFACE 18.1" NARROW
11	6871TPT219B	PWB(PCB) ASSEMBLY, POWER, LB886F POWER TOTAL BRAND CL-29
12	4814TKK187A	SHIELD, REAR LB886F
13	4951TKK071F	METAL ASSEMBLY, REAR LB782F
14	6631T25005D	 CONNECTOR ASSEMBLY, SWITCH(GY)+CONN.ASSYP H-W 180MM UL 1617 AWG 22
15	3550TKK220A	COVER, LB886F STAND TOP FRONT
16	3550TKK218B	COVER, LB886F STAND FRONT HIPS-60HR
17	3550TKK222B	COVER, LB886F BASE TOP HIPS-60HR
18	6871TUT015A	PWB(PCB) ASSEMBLY, USB, LB886F SUB TOTAL BRAND CL-29
19	3550TKK223B	COVER, LB886F PIECE CABLE, HIPS-60HR
20	3550TKK219B	COVER, LB886F STAND REAR, HIPS-60HR
21	3550TKK221A	COVER, LB886F STAND TOP REAR
22	3550TKK217B	COVER, LB886F HINGE REAR, HIPS-60HR
23	3550TKK216B	COVER, LB886F HINGE TOP, HIPS-60HR
24	4950TKK346A	METAL, PLATE STOPPER, LB886F
25	3550TKK224A	COVER, PIECE LOCK
26	4970TKK008A	SPRING, COIL, PLATE NO DIM, FOR STAND T=0.45 LB886F
27	4950TKK345A	METAL, FIX SPRING, LB886F
28	3551TKS039A	COVER ASSEMBLY, LB886F SPEAKER - BRAND(ABS-EQ22)
29	3550TKS057B	COVER, LB886F SPEAKER -FRONT(ABS-EQ22)
30	3550TKS058B	COVER, LB886F SPEAKER -BACK(ABS-EQ22)
31	4950TKK337A	METAL, FIX SPEAKER (LM568E)
32	6871TST288A	PWB(PCB) ASSEMBLY, SUB, LB886F SOUND TOTAL BRAND CL-29
33	6401TZZ027A	SPEAKER ASSEMBLY, LB886F -18" LCD
34	1SZZTMT002B	SCREW, DRAWING, D3.0 L13.0 SUS27/FN LB782F(BRAND)
35	6852TAZ006G	CORD, A/V, A/V KHC-LG-3-0008 UL 2851 #28 1560MM GRAY(85964) K
36	6852TAZ004J	CORD, LINE, DC CABLE UNIXTAR 160 GRAY LB886F,ANGLE TYPE
37	6850TD9001B	CABLE, D-SUB, UL 2990-9C DT 1870MM GRAY(85964) LB886F WITH S/R
38	6866TDV004H	CABLE, DVI, UL20276 DT 2000MM GRAY(85964) LB886F DM
39	6866TDU002D	SIGNAL CABLE, UL20276SB10P+2C AWG#30 DT 1870MM GRAY(85964) BRAND
A	3313TL8014B	MAIN TOTAL ASSEMBLY, LB886F BRAND CL-29
a	1SZZTER001F	SCREW, DRAWING, D3.0 L10.0 (MSWR/FZMCW1)
b	332-113N	SCREW, PVP+3*12(MSWR/FZMW)
c	332-105F	SCREW, PVS+4*10(MSWR/FZMW)

REPLACEMENT PARTS LIST

CAUTION: BEFORE REPLACING ANY OF THESE COMPONENTS,
READ CAREFULLY THE **SAFETY PRECAUTIONS** IN THIS MANUAL.

* NOTE : **S** SAFETY Mark Δ
AL ALTERNATIVE PARTS

DATE: 2002. 02. 18.				
*S	*AL	LOC. NO.	PART NO.	DESCRIPTION / SPECIFICATION
MAIN BOARD				
CAPACITORS				
		C106	OCC101CK41A	100PF 1608 50V 5% R/TP NPO
		C107	OCC101CK41A	100PF 1608 50V 5% R/TP NPO
		C108	DCH7476C621	47UF 6.3V M 3528 TP(-)
		C109	OCK103CK51A	0.01UF 1608 50V 10% R/TP B(Y)
		C110	DCH7476C621	47UF 6.3V M 3528 TP(-)
		C111	OCK103CK51A	0.01UF 1608 50V 10% R/TP B(Y)
		C112	DCH7476C621	47UF 6.3V M 3528 TP(-)
		C113	OCK103CK51A	0.01UF 1608 50V 10% R/TP B(Y)
		C114	DCH7476C621	47UF 6.3V M 3528 TP(-)
		C115	OCK103CK51A	0.01UF 1608 50V 10% R/TP B(Y)
		C116	DCH7476C621	47UF 6.3V M 3528 TP(-)
		C117	OCK103CK51A	0.01UF 1608 50V 10% R/TP B(Y)
		C118	DCH7476C621	47UF 6.3V M 3528 TP(-)
		C119	OCK103CK51A	0.01UF 1608 50V 10% R/TP B(Y)
		C120	OCC102CK41A	1000PF 1608 50V 5% R/TP NPO
		C122	OCH8106F611	10UF 16V M 85STD(CYL) R/TP
		C123	OCK104CK56A	0.1UF 1608 50V 10% R/TP X7R
		C124	OCK104CK56A	0.1UF 1608 50V 10% R/TP X7R
		C125	OCE107WF6DC	100UF MVK 16V 20% R/TP(SMD)
		C128	OCK104CK56A	0.1UF 1608 50V 10% R/TP X7R
		C130	OCC102CK41A	1000PF 1608 50V 5% R/TP NPO
		C131	OCC102CK41A	1000PF 1608 50V 5% R/TP NPO
		C160	OCK103CK51A	0.01UF 1608 50V 10% R/TP B(Y)
		C161	OCK104CK56A	0.1UF 1608 50V 10% R/TP X7R
		C201	OCH3103K516	10000PF 50V K B 2012 R/TP
		C202	OCH3103K516	10000PF 50V K B 2012 R/TP
		C203	OCH3103K516	10000PF 50V K B 2012 R/TP
		C204	OCH3103K516	10000PF 50V K B 2012 R/TP
		C205	OCH3103K516	10000PF 50V K B 2012 R/TP
		C206	OCH3103K516	10000PF 50V K B 2012 R/TP
		C207	OCH3103K516	10000PF 50V K B 2012 R/TP
		C208	OCH3103K516	10000PF 50V K B 2012 R/TP
		C209	OCH3103K516	10000PF 50V K B 2012 R/TP
		C210	OCH3103K516	10000PF 50V K B 2012 R/TP
		C211	OCH3103K516	10000PF 50V K B 2012 R/TP
		C212	OCH3103K516	10000PF 50V K B 2012 R/TP
		C213	OCH3103K516	10000PF 50V K B 2012 R/TP
		C214	OCH3103K516	10000PF 50V K B 2012 R/TP
		C215	OCH3103K516	10000PF 50V K B 2012 R/TP
		C216	OCH3103K516	10000PF 50V K B 2012 R/TP
		C217	OCH3103K516	10000PF 50V K B 2012 R/TP
		C218	OCH3104K566	0.1UF 50V K X 2012 R/TP
		C219	OCH3103K516	10000PF 50V K B 2012 R/TP
		C220	OCH6330K416	33PF 50V J NPO 2012 R/TP
		C221	OCH6330K416	33PF 50V J NPO 2012 R/TP
		C222	OCH3103K516	10000PF 50V K B 2012 R/TP
		C223	OCH3103K516	10000PF 50V K B 2012 R/TP
		C224	OCH3103K516	10000PF 50V K B 2012 R/TP
		C225	OCH3103K516	10000PF 50V K B 2012 R/TP
		C226	OCH3103K516	10000PF 50V K B 2012 R/TP
		C227	OCH3104K566	0.1UF 50V K X 2012 R/TP
		C228	OCH3103K516	10000PF 50V K B 2012 R/TP

DATE: 2002. 02. 18.					
*S	*AL	LOC. NO.	PART NO.	DESCRIPTION / SPECIFICATION	
			C229	OCC102CK41A	1000PF 1608 50V 5% R/TP NPO
			C230	OCH6150K416	15PF 50V J NPO 2012 R/TP
			C231	OCH6680K416	68PF 50V J NPO 2012 R/TP
			C232	OCH6680K416	68PF 50V J NPO 2012 R/TP
			C233	OCH3103K516	10000PF 50V K B 2012 R/TP
			C234	OCH3103K516	10000PF 50V K B 2012 R/TP
			C235	OCH6680K416	68PF 50V J NPO 2012 R/TP
			C236	OCH6680K416	68PF 50V J NPO 2012 R/TP
			C237	OCH3104K566	0.1UF 50V K X 2012 R/TP
			C258	OCH6150K416	15PF 50V J NPO 2012 R/TP
			C259	OCH3682K516	6800PF 50V K B(Y5P) 2012 R/T
			C260	OCH3682K516	6800PF 50V K B(Y5P) 2012 R/T
			C261	OCH3682K516	6800PF 50V K B(Y5P) 2012 R/T
			C262	OCH6330K416	33PF 50V J NPO 2012 R/TP
			C264	OCH6221K416	220PF 50V J NPO 2012 R/TP
			C265	OCH6470K416	47PF 50V J NPO 2012 R/TP
			C269	OCH3103K516	10000PF 50V K B 2012 R/TP
			C270	OCK104CK56A	0.1UF 1608 50V 10% R/TP X7R
			C271	OCK103CK51A	0.01UF 1608 50V 10% R/TP B(Y)
			C272	OCH3104K566	0.1UF 50V K X 2012 R/TP
			C273	OCH3103K516	10000PF 50V K B 2012 R/TP
			C274	OCH3103K516	10000PF 50V K B 2012 R/TP
			C275	OCH3104K566	0.1UF 50V K X 2012 R/TP
			C276	OCH3103K516	10000PF 50V K B 2012 R/TP
			C278	OCK104CK56A	0.1UF 1608 50V 10% R/TP X7R
			C279	OCK104CK56A	0.1UF 1608 50V 10% R/TP X7R
			C280	OCK104CK56A	0.1UF 1608 50V 10% R/TP X7R
			C301	OCK103CK51A	0.01UF 1608 50V 10% R/TP B(Y)
			C302	OCK103CK51A	0.01UF 1608 50V 10% R/TP B(Y)
			C303	OCK103CK51A	0.01UF 1608 50V 10% R/TP B(Y)
			C304	OCK103CK51A	0.01UF 1608 50V 10% R/TP B(Y)
			C305	OCK103CK51A	0.01UF 1608 50V 10% R/TP B(Y)
			C306	OCK103CK51A	0.01UF 1608 50V 10% R/TP B(Y)
			C307	OCK103CK51A	0.01UF 1608 50V 10% R/TP B(Y)
			C308	OCK103CK51A	0.01UF 1608 50V 10% R/TP B(Y)
			C309	OCK103CK51A	0.01UF 1608 50V 10% R/TP B(Y)
			C310	OCK103CK51A	0.01UF 1608 50V 10% R/TP B(Y)
			C311	OCK103CK51A	0.01UF 1608 50V 10% R/TP B(Y)
			C312	OCK103CK51A	0.01UF 1608 50V 10% R/TP B(Y)
			C313	OCK103CK51A	0.01UF 1608 50V 10% R/TP B(Y)
			C314	OCK103CK51A	0.01UF 1608 50V 10% R/TP B(Y)
			C315	OCK103CK51A	0.01UF 1608 50V 10% R/TP B(Y)
			C316	OCK103CK51A	0.01UF 1608 50V 10% R/TP B(Y)
			C317	OCK103CK51A	0.01UF 1608 50V 10% R/TP B(Y)
			C318	OCK103CK51A	0.01UF 1608 50V 10% R/TP B(Y)
			C401	OCK103CK51A	0.01UF 1608 50V 10% R/TP B(Y)
			C402	OCK103CK51A	0.01UF 1608 50V 10% R/TP B(Y)
			C403	OCK103CK51A	0.01UF 1608 50V 10% R/TP B(Y)
			C404	OCK103CK51A	0.01UF 1608 50V 10% R/TP B(Y)
			C405	OCK103CK51A	0.01UF 1608 50V 10% R/TP B(Y)
			C406	OCK103CK51A	0.01UF 1608 50V 10% R/TP B(Y)
			C407	OCK103CK51A	0.01UF 1608 50V 10% R/TP B(Y)
			C408	OCH8226F691	22UF 16V M 105STD (CYL) R/TP
			C409	OCE107WF6DC	100UF MVK 16V 20% R/TP(SMD)

DATE: 2002. 02. 18.

*S	*AL	LOC. NO.	PART NO.	DESCRIPTION / SPECIFICATION
		C410	0CE107WF6DC	100UF MVK 16V 20% R/TP(SMD)
		C411	0CK103CK51A	0.01UF 1608 50V 10% R/TP B(Y)
		C412	0CC102CK41A	1000PF 1608 50V 5% R/TP NP0
		C413	0CE107WF6DC	100UF MVK 16V 20% R/TP(SMD)
		C501	0CC180CK41A	18PF 1608 50V 5% R/TP NP0
		C502	0CC180CK41A	18PF 1608 50V 5% R/TP NP0
		C503	0CK104CK56A	0.1UF 1608 50V 10% R/TP X7R
		C504	0CC470CK41A	47PF 1608 50V 5% R/TP NP0
		C505	0CC470CK41A	47PF 1608 50V 5% R/TP NP0
		C506	0CC470CK41A	47PF 1608 50V 5% R/TP NP0
		C507	0CC470CK41A	47PF 1608 50V 5% R/TP NP0
		C508	0CK222CK51A	2200PF 1608 50V 10% R/TP B(Y)
		C510	0CK104CK56A	0.1UF 1608 50V 10% R/TP X7R
		C511	0CK104CK56A	0.1UF 1608 50V 10% R/TP X7R
		C513	0CK104CK56A	0.1UF 1608 50V 10% R/TP X7R
		C514	0CC470CK41A	47PF 1608 50V 5% R/TP NP0
		C515	0CC470CK41A	47PF 1608 50V 5% R/TP NP0
		C516	0CC101CK41A	100PF 1608 50V 5% R/TP NP0
		C517	0CC101CK41A	100PF 1608 50V 5% R/TP NP0
		C519	0CC101CK41A	100PF 1608 50V 5% R/TP NP0
		C520	0CC101CK41A	100PF 1608 50V 5% R/TP NP0
		C521	0CK103CK51A	0.01UF 1608 50V 10% R/TP B(Y)
		C522	0CK103CK51A	0.01UF 1608 50V 10% R/TP B(Y)
		C526	0CH8106J691	10UF 35V M 105STD (CYL) R/TP
		C531	0CK103CK51A	0.01UF 1608 50V 10% R/TP B(Y)
		C532	0CH8106J691	10UF 35V M 105STD (CYL) R/TP
		C533	0CK104CK56A	0.1UF 1608 50V 10% R/TP X7R
		C548	0CK104CK56A	0.1UF 1608 50V 10% R/TP X7R
		C701	0CE477EH618	470UF KMG 25V M FL TP 5
		C706	0CC221CK41A	220PF 1608 50V 5% R/TP NP0
		C707	0CH8106J691	10UF 35V M 105STD (CYL) R/TP
		C710	0CK103CK51A	0.01UF 1608 50V 10% R/TP B(Y)
		C714	0CC101CK41A	100PF 1608 50V 5% R/TP NP0
		C715	0CC101CK41A	100PF 1608 50V 5% R/TP NP0
		C727	0CC101CK41A	100PF 1608 50V 5% R/TP NP0
		C728	0CC101CK41A	100PF 1608 50V 5% R/TP NP0
		C729	0CK104CK56A	0.1UF 1608 50V 10% R/TP X7R
		C730	0CK103CK51A	0.01UF 1608 50V 10% R/TP B(Y)
		C731	0CK103CK51A	0.01UF 1608 50V 10% R/TP B(Y)
		C738	0CK103CK51A	0.01UF 1608 50V 10% R/TP B(Y)
		C740	0CK104CK56A	0.1UF 1608 50V 10% R/TP X7R
		C817	0CE107WF6DC	100UF MVK 16V 20% R/TP(SMD)
		C818	0CC102CK41A	1000PF 1608 50V 5% R/TP NP0
		C819	0CK103CK51A	0.01UF 1608 50V 10% R/TP B(Y)
		C820	0CC102CK41A	1000PF 1608 50V 5% R/TP NP0
		C822	0CE107WF6DC	100UF MVK 16V 20% R/TP(SMD)
		C823	0CK103CK51A	0.01UF 1608 50V 10% R/TP B(Y)
		C824	0CC102CK41A	1000PF 1608 50V 5% R/TP NP0
		C825	0CE107WF6DC	100UF MVK 16V 20% R/TP(SMD)
		C826	0CK103CK51A	0.01UF 1608 50V 10% R/TP B(Y)
		C827	0CC102CK41A	1000PF 1608 50V 5% R/TP NP0
		C828	0CE107WF6DC	100UF MVK 16V 20% R/TP(SMD)
		C829	0CC102CK41A	1000PF 1608 50V 5% R/TP NP0
		C830	0CK103CK51A	0.01UF 1608 50V 10% R/TP B(Y)
		C831	0CE107WF6DC	100UF MVK 16V 20% R/TP(SMD)
		C832	0CK103CK51A	0.01UF 1608 50V 10% R/TP B(Y)
		C833	0CC102CK41A	1000PF 1608 50V 5% R/TP NP0
		C834	0CE107WF6DC	100UF MVK 16V 20% R/TP(SMD)
		C835	0CC102CK41A	1000PF 1608 50V 5% R/TP NP0
		C836	0CK103CK51A	0.01UF 1608 50V 10% R/TP B(Y)
		C840	0CE477EH618	470UF KMG 25V M FL TP 5
		C841	0CC102CK41A	1000PF 1608 50V 5% R/TP NP0

DATE: 2002. 02. 18.

*S	*AL	LOC. NO.	PART NO.	DESCRIPTION / SPECIFICATION
		C842	0CK103CK51A	0.01UF 1608 50V 10% R/TP B(Y)
		C843	0CC102CK41A	1000PF 1608 50V 5% R/TP NP0
		C844	0CE107WF6DC	100UF MVK 16V 20% R/TP(SMD)
		C845	0CE477EH618	470UF KMG 25V M FL TP 5
		C850	0CE477EH618	470UF KMG 25V M FL TP 5
		C860	0CC102CK41A	1000PF 1608 50V 5% R/TP NP0
		C861	0CK105CD56A	1UF 1608 10V 10% R/TP X7R
		C870	0CC102CK41A	1000PF 1608 50V 5% R/TP NP0
		C871	0CH6101K416	100PF 50V J NP0 2012 R/TP
		C872	0CC102CK41A	1000PF 1608 50V 5% R/TP NP0
		C873	0CH6101K416	100PF 50V J NP0 2012 R/TP
DIODES				
		D501	0DS301109AA	MMBD301LT1 TP MOTOROLA SOT23
		D502	0DS301109AA	MMBD301LT1 TP MOTOROLA SOT23
		D503	0DS301109AA	MMBD301LT1 TP MOTOROLA SOT23
		D504	0DS301109AA	MMBD301LT1 TP MOTOROLA SOT23
		D701	0DS226009AA	KDS226 TP KEC SOT-23 80V 30
		D702	0DS226009AA	KDS226 TP KEC SOT-23 80V 30
		D703	0DS226009AA	KDS226 TP KEC SOT-23 80V 30
		D704	0DS226009AA	KDS226 TP KEC SOT-23 80V 30
		D712	0DS226009AA	KDS226 TP KEC SOT-23 80V 30
		D713	0DS226009AA	KDS226 TP KEC SOT-23 80V 30
		D714	0DS226009AA	KDS226 TP KEC SOT-23 80V 30
		D715	0DS226009AA	KDS226 TP KEC SOT-23 80V 30
		D716	0DS226009AA	KDS226 TP KEC SOT-23 80V 30
		D730	0DS226009AA	KDS226 TP KEC SOT-23 80V 30
		D731	0DS226009AA	KDS226 TP KEC SOT-23 80V 30
		D732	0DS226009AA	KDS226 TP KEC SOT-23 80V 30
		D733	0DS226009AA	KDS226 TP KEC SOT-23 80V 30
		D734	0DS226009AA	KDS226 TP KEC SOT-23 80V 30
		D735	0DS226009AA	KDS226 TP KEC SOT-23 80V 30
		D736	0DS226009AA	KDS226 TP KEC SOT-23 80V 30
		D737	0DS226009AA	KDS226 TP KEC SOT-23 80V 30
		D738	0DS226009AA	KDS226 TP KEC SOT-23 80V 30
		D739	0DS226009AA	KDS226 TP KEC SOT-23 80V 30
		D903	0DRIR00011B	16CTQ100 I.R ST TO220 100V 1
		D906	0DRIR00021A	30CTQ060 I.R ST TO220 60V 30
		ZD701	0DZ560009DA	UDZ S 5.6B TP ROHM-K SOD323
		ZD702	0DZ560009DA	UDZ S 5.6B TP ROHM-K SOD323
		ZD703	0DZ560009DA	UDZ S 5.6B TP ROHM-K SOD323
		ZD704	0DZ560009DA	UDZ S 5.6B TP ROHM-K SOD323
		ZD705	0DZ560009DA	UDZ S 5.6B TP ROHM-K SOD323
		ZD711	0DZ560009DA	UDZ S 5.6B TP ROHM-K SOD323
		ZD721	0DZ560009DA	UDZ S 5.6B TP ROHM-K SOD323
		ZD722	0DZ560009DA	UDZ S 5.6B TP ROHM-K SOD323
ICs				
		U105	0IMO741420B	MC74HCT14ADR2 14P,SOIC TP LE
		U106	0IRH765700B	BA7657F 24P,SOP TP INPUT SIG
		U107	0ITI748600N	SN74F86DR 14SOIC TP 2-INPUT
		U108	0IPH740800H	74F08D 14P,SOIC TP QUAD 2-IN
		U109	0TFFC80009A	FAIRCHILD FDC6326L R/TP SOT-
		U110	0ISS780500H	KA78M05-R 3P,D-PAK TP 5V 0.5
		U201	0IIPRPGN001A	GM5020 GENESIS 292P,PBGA TRA
		U301	0IEB121616A	M12L16161A-7T 50P TSOP ST 16
		U302	0IEB121616A	M12L16161A-7T 50P TSOP ST 16
		U303	0IEB121616A	M12L16161A-7T 50P TSOP ST 16
		U401	0ILNRTH001A	THC63LVD823 THINE MICROSYSTE
		U501	0IZZTSTZ160A	42P BK

*S	*AL	LOC. NO.	PART NO.	DESCRIPTION / SPECIFICATION
		U502	0IKE704200J	KIA7042AF SOT-89 TP 4.2V VOL
		U503	0ICS240813B	CAT24WC08J-TE13 8P,SOIC R/TP
		U504	0ISS524202A	S524C20D21-SCT0 8SOP-225 R/T
		U509	0ISS524202A	S524C20D21-SCT0 8SOP-225 R/T
		U701	0DZ560009DA	UDZ S 5.6B TP ROHM-K SOD323
		U802	0TFFC80009A	FAIRCHILD FDC6326L R/TP SOT-
		U803	0IPMGFA003B	RC1117S-2.5 FAIRCHILD SOT-22
		U804	0TFFC80009A	FAIRCHILD FDC6326L R/TP SOT-
		U820	0IRH033200A	BA033FP-E2 MOLD-3 TP REGULAT
		U821	0IRH033200A	BA033FP-E2 MOLD-3 TP REGULAT

COILs & COREs

L101			6210TCE001G	HH-1M3216-501 CERATEC 3216MM
L201			0RH0562D622	56 1/10W 5 D.R/TP
L202			6210TCE001P	HB-1S2012-121JT CERATECH 201
L203			6210TCE001P	HB-1S2012-121JT CERATECH 201
L204			6210TCE001P	HB-1S2012-121JT CERATECH 201
L205			6210TCE001R	HB-1S2012-400JT CERATECH 201
L206			6210TCE001P	HB-1S2012-121JT CERATECH 201
L207			6210TCE001P	HB-1S2012-121JT CERATECH 201
L401			6210TCE001G	HH-1M3216-501 CERATEC 3216MM
L402			6210TCE001G	HH-1M3216-501 CERATEC 3216MM
L403			6210TCE001G	HH-1M3216-501 CERATEC 3216MM
L703			6210TCE001G	HH-1M3216-501 CERATEC 3216MM
L704			6210TCE001G	HH-1M3216-501 CERATEC 3216MM
L804			6210TCE001G	HH-1M3216-501 CERATEC 3216MM
L805			6210TCE001G	HH-1M3216-501 CERATEC 3216MM
L810			6210TCE001G	HH-1M3216-501 CERATEC 3216MM
L811			6210TCE001G	HH-1M3216-501 CERATEC 3216MM
L820			6210TCE001G	HH-1M3216-501 CERATEC 3216MM
L821			6210TCE001G	HH-1M3216-501 CERATEC 3216MM
L822			6210TCE001P	HB-1S2012-121JT CERATECH 201
L823			6210TCE001G	HH-1M3216-501 CERATEC 3216MM

TRANSISTOR

Q102			0TR390409AE	FAIRCHILD KST3904(LGEMTF) TP
Q103			0TR390409AE	FAIRCHILD KST3904(LGEMTF) TP
Q104			0TR162309CA	KSC1623 TP SAMSUNG SOT23 NP
Q703			0TR162309CA	KSC1623 TP SAMSUNG SOT23 NP
Q704			0TR162309CA	KSC1623 TP SAMSUNG SOT23 NP
Q902			0TFFN10004A	INFINEON SPP11N60C2 ST TO220

RESISTORs

R122			0RJ1002D677	10K OHM 1/10 W 5% 1608 R/TP
R129			0RJ1002D677	10K OHM 1/10 W 5% 1608 R/TP
R130			0RJ4701D677	4.7K OHM 1/10 W 5% 1608 R/TP
R131			0RJ4701D677	4.7K OHM 1/10 W 5% 1608 R/TP
R132			0RJ1001D677	1K OHM 1/10 W 5% 1608 R/TP
R133			0RJ1001D677	1K OHM 1/10 W 5% 1608 R/TP
R134			0RJ1001D677	1K OHM 1/10 W 5% 1608 R/TP
R135			0RJ4703D677	470K OHM 1/10 W 5% 1608 R/TP
R139			0RJ1001D677	1K OHM 1/10 W 5% 1608 R/TP
R140			0RJ1003D677	100K OHM 1/10 W 5% 1608 R/TP
R141			0RJ1000D677	100 OHM 1/10 W 5% 1608 R/TP
R142			0RJ1000D677	100 OHM 1/10 W 5% 1608 R/TP
R145			0RJ0222D677	22 OHM 1/10 W 5% 1608 R/TP
R146			0RJ1001D677	1K OHM 1/10 W 5% 1608 R/TP
R147			0RJ4701D677	4.7K OHM 1/10 W 5% 1608 R/TP
R149			0RJ2000D677	200 OHM 1/10 W 5% 1608 R/TP

*S	*AL	LOC. NO.	PART NO.	DESCRIPTION / SPECIFICATION
R150			0RJ0222D677	22 OHM 1/10 W 5% 1608 R/TP
R151			0RJ1500D677	150 OHM 1/10 W 5% 1608 R/TP
R153			0RJ2202D677	22K OHM 1/10 W 5% 1608 R/TP
R154			0RJ1000D677	100 OHM 1/10 W 5% 1608 R/TP
R155			0RJ1000D677	100 OHM 1/10 W 5% 1608 R/TP
R201			0RH2001D622	2.0K 1/10W 5 D.R/TP
R202			0RH2001D622	2.0K 1/10W 5 D.R/TP
R203			0RJ1002D677	10K OHM 1/10 W 5% 1608 R/TP
R204			0RJ1002D677	10K OHM 1/10 W 5% 1608 R/TP
R205			0RJ1002D677	10K OHM 1/10 W 5% 1608 R/TP
R206			0RJ1002D677	10K OHM 1/10 W 5% 1608 R/TP
R207			0RJ1002D677	10K OHM 1/10 W 5% 1608 R/TP
R208			0RJ1002D677	10K OHM 1/10 W 5% 1608 R/TP
R209			0RJ1002D677	10K OHM 1/10 W 5% 1608 R/TP
R210			0RJ1002D677	10K OHM 1/10 W 5% 1608 R/TP
R211			0RJ1002D677	10K OHM 1/10 W 5% 1608 R/TP
R212			0RJ1002D677	10K OHM 1/10 W 5% 1608 R/TP
R213			0RJ1002D677	10K OHM 1/10 W 5% 1608 R/TP
R214			0RJ1002D677	10K OHM 1/10 W 5% 1608 R/TP
R215			0RJ1002D677	10K OHM 1/10 W 5% 1608 R/TP
R216			0RJ1002D677	10K OHM 1/10 W 5% 1608 R/TP
R218			0RJ1000D677	100 OHM 1/10 W 5% 1608 R/TP
R219			0RJ1000D677	100 OHM 1/10 W 5% 1608 R/TP
R220			0RJ0752D677	75 OHM 1/10 W 5% 1608 R/TP
R221			0RJ0752D677	75 OHM 1/10 W 5% 1608 R/TP
R222			0RJ0752D677	75 OHM 1/10 W 5% 1608 R/TP
R223			0RJ1500D677	150 OHM 1/10 W 5% 1608 R/TP
R224			0RJ1500D677	150 OHM 1/10 W 5% 1608 R/TP
R225			0RJ1500D677	150 OHM 1/10 W 5% 1608 R/TP
R233			0RH0222D622	22 1/10W 5 D.R/TP
R234			0RH0222D622	22 1/10W 5 D.R/TP
R235			0RJ2201D677	2200 OHM 1/10 W 5% 1608 R/TP
R236			0RJ0000D677	0 OHM 1/10 W 5% 1608 R/TP
R237			0RH0000D622	0 1/10W P-TYPE TAPPING
R238			0RH0000D622	0 1/10W P-TYPE TAPPING
R239			0RJ0000D677	0 OHM 1/10 W 5% 1608 R/TP
R240			0RJ0000D677	0 OHM 1/10 W 5% 1608 R/TP
R401			0RJ1002D677	10K OHM 1/10 W 5% 1608 R/TP
R402			0RJ1002D677	10K OHM 1/10 W 5% 1608 R/TP
R404			0RJ1002D677	10K OHM 1/10 W 5% 1608 R/TP
R405			0RJ1002D677	10K OHM 1/10 W 5% 1608 R/TP
R406			0RJ0000D677	0 OHM 1/10 W 5% 1608 R/TP
R501			0RJ1004D677	1000000 OHM 1/10 W 5% 1608 R
R502			0RJ0000D677	0 OHM 1/10 W 5% 1608 R/TP
R505			0RJ1002D677	10K OHM 1/10 W 5% 1608 R/TP
R508			0RJ4700D677	470 OHM 1/10 W 5% 1608 R/TP
R511			0RJ1000D677	100 OHM 1/10 W 5% 1608 R/TP
R512			0RJ1000D677	100 OHM 1/10 W 5% 1608 R/TP
R513			0RJ1000D677	100 OHM 1/10 W 5% 1608 R/TP
R514			0RJ1000D677	100 OHM 1/10 W 5% 1608 R/TP
R515			0RJ4701D677	4.7K OHM 1/10 W 5% 1608 R/TP
R516			0RH1001D622	1K OHM 1 / 10 W 2012 5.00% D
R517			0RJ4700D677	470 OHM 1/10 W 5% 1608 R/TP
R518			0RH1001D622	1K OHM 1 / 10 W 2012 5.00% D
R519			0RJ4700D677	470 OHM 1/10 W 5% 1608 R/TP
R522			0RJ1000D677	100 OHM 1/10 W 5% 1608 R/TP
R523			0RJ1000D677	100 OHM 1/10 W 5% 1608 R/TP
R524			0RJ1000D677	100 OHM 1/10 W 5% 1608 R/TP
R525			0RJ1000D677	100 OHM 1/10 W 5% 1608 R/TP
R526			0RJ1000D677	100 OHM 1/10 W 5% 1608 R/TP
R527			0RJ1003D677	100K OHM 1/10 W 5% 1608 R/TP
R528			0RJ0222D677	22 OHM 1/10 W 5% 1608 R/TP

DATE: 2002. 02. 18.

*S	*AL	LOC. NO.	PART NO.	DESCRIPTION / SPECIFICATION
		R529	0RJ1002D677	10K OHM 1/10 W 5% 1608 R/TP
		R531	0RJ3302D677	33K OHM 1/10 W 5% 1608 R/TP
		R534	0RJ1001D677	1K OHM 1/10 W 5% 1608 R/TP
		R535	0RJ0000D677	0 OHM 1/10 W 5% 1608 R/TP
		R536	0RJ1000D677	100 OHM 1/10 W 5% 1608 R/TP
		R537	0RJ1000D677	100 OHM 1/10 W 5% 1608 R/TP
		R538	0RJ4701D677	4.7K OHM 1/10 W 5% 1608 R/TP
		R539	0RJ4701D677	4.7K OHM 1/10 W 5% 1608 R/TP
		R540	0RJ0222D677	22 OHM 1/10 W 5% 1608 R/TP
		R541	0RJ4700D677	470 OHM 1/10 W 5% 1608 R/TP
		R542	0RJ1000D677	100 OHM 1/10 W 5% 1608 R/TP
		R543	0RJ1000D677	100 OHM 1/10 W 5% 1608 R/TP
		R544	0RJ4701D677	4.7K OHM 1/10 W 5% 1608 R/TP
		R545	0RJ4701D677	4.7K OHM 1/10 W 5% 1608 R/TP
		R564	0RJ4701D677	4.7K OHM 1/10 W 5% 1608 R/TP
		R580	0RJ4701D677	4.7K OHM 1/10 W 5% 1608 R/TP
		R581	0RJ1000D677	100 OHM 1/10 W 5% 1608 R/TP
		R582	0RJ1000D677	100 OHM 1/10 W 5% 1608 R/TP
		R585	0RJ4701D677	4.7K OHM 1/10 W 5% 1608 R/TP
		R586	0RJ4701D677	4.7K OHM 1/10 W 5% 1608 R/TP
		R587	0RJ1000D677	100 OHM 1/10 W 5% 1608 R/TP
		R588	0RJ1000D677	100 OHM 1/10 W 5% 1608 R/TP
		R591	0RJ0000D677	0 OHM 1/10 W 5% 1608 R/TP
		R592	0RJ0000D677	0 OHM 1/10 W 5% 1608 R/TP
		R593	0RJ4701D677	4.7K OHM 1/10 W 5% 1608 R/TP
		R594	0RJ4701D677	4.7K OHM 1/10 W 5% 1608 R/TP
		R595	0RJ1000D677	100 OHM 1/10 W 5% 1608 R/TP
		R596	0RJ1000D677	100 OHM 1/10 W 5% 1608 R/TP
		R597	0RJ0000D677	0 OHM 1/10 W 5% 1608 R/TP
		R701	0RJ1002D677	10K OHM 1/10 W 5% 1608 R/TP
		R703	0RJ0752D677	75 OHM 1/10 W 5% 1608 R/TP
		R704	0RJ0752D677	75 OHM 1/10 W 5% 1608 R/TP
		R705	0RJ0752D677	75 OHM 1/10 W 5% 1608 R/TP
		R711	0RJ1000D677	100 OHM 1/10 W 5% 1608 R/TP
		R712	0RJ1000D677	100 OHM 1/10 W 5% 1608 R/TP
		R713	0RJ0472D677	47 OHM 1/10 W 5% 1608 R/TP
		R714	0RJ1801D677	1.8K OHM 1/10 W 5% 1608 R/TP
		R715	0RJ1002D677	10K OHM 1/10 W 5% 1608 R/TP
		R716	0RJ0472D677	47 OHM 1/10 W 5% 1608 R/TP
		R718	0RJ0222D677	22 OHM 1/10 W 5% 1608 R/TP
		R719	0RJ0222D677	22 OHM 1/10 W 5% 1608 R/TP
		R726	0RJ1000D677	100 OHM 1/10 W 5% 1608 R/TP
		R727	0RJ1000D677	100 OHM 1/10 W 5% 1608 R/TP
		R729	0RJ4700D677	470 OHM 1/10 W 5% 1608 R/TP
		R730	0RJ2700D677	270 OHM 1/10 W 5% 1608 R/TP
		R731	0RJ2700D677	270 OHM 1/10 W 5% 1608 R/TP
		R740	0RH0000D622	0 1/10W P-TYPE TAPPING
		R741	0RH0000D622	0 1/10W P-TYPE TAPPING
		R742	0RH0000D622	0 1/10W P-TYPE TAPPING
		R743	0RH0000D622	0 1/10W P-TYPE TAPPING
		R744	0RH0000D622	0 1/10W P-TYPE TAPPING
		R745	0RH0000D622	0 1/10W P-TYPE TAPPING
		R746	0RH0000D622	0 1/10W P-TYPE TAPPING
		R752	0RJ1003D677	100K OHM 1/10 W 5% 1608 R/TP
		R753	0RJ4701D677	4.7K OHM 1/10 W 5% 1608 R/TP
		R760	0RJ0472D677	47 OHM 1/10 W 5% 1608 R/TP
		R761	0RJ0472D677	47 OHM 1/10 W 5% 1608 R/TP
		R765	0RJ0752D677	75 OHM 1/10 W 5% 1608 R/TP
		R766	0RJ0752D677	75 OHM 1/10 W 5% 1608 R/TP
		R767	0RJ0752D677	75 OHM 1/10 W 5% 1608 R/TP
		R768	0RJ1801D677	1.8K OHM 1/10 W 5% 1608 R/TP
		R769	0RJ1002D677	10K OHM 1/10 W 5% 1608 R/TP

DATE: 2002. 02. 18.

*S	*AL	LOC. NO.	PART NO.	DESCRIPTION / SPECIFICATION
		R807	0RH0000D622	0 1/10W P-TYPE TAPPING
		R809	0RJ2202D677	22K OHM 1/10 W 5% 1608 R/TP
		R810	0RH5600D622	560 1/10W 5 D.R/TP
		R811	0RH0332D622	33 1/10W 5 D.R/TP
		R812	0RH0332D622	33 1/10W 5 D.R/TP
		R813	0RH0332D622	33 1/10W 5 D.R/TP
		R814	0RH0332D622	33 1/10W 5 D.R/TP
		R815	0RH0332D622	33 1/10W 5 D.R/TP
		R816	0RH0332D622	33 1/10W 5 D.R/TP
		R817	0RH0332D622	33 1/10W 5 D.R/TP
		R818	0RH0332D622	33 1/10W 5 D.R/TP
		R819	0RH0332D622	33 1/10W 5 D.R/TP
		R820	0RH0332D622	33 1/10W 5 D.R/TP
		R821	0RJ2202D677	22K OHM 1/10 W 5% 1608 R/TP
		R822	0RH5600D622	560 1/10W 5 D.R/TP
		R824	0RJ0000D677	0 OHM 1/10 W 5% 1608 R/TP
		R826	0RH0332D622	33 1/10W 5 D.R/TP
		R827	0RH0332D622	33 1/10W 5 D.R/TP
		R828	0RH0332D622	33 1/10W 5 D.R/TP
		R829	0RH0332D622	33 1/10W 5 D.R/TP
		R830	0RH0332D622	33 1/10W 5 D.R/TP
		RA202	0RHZTCZ001A	100 OHM 1/16 W 5% 3215 R/TP
		RA204	0RHZTCZ001A	100 OHM 1/16 W 5% 3215 R/TP
		RA206	0RHZTCZ001A	100 OHM 1/16 W 5% 3215 R/TP
		RA208	0RHZTCZ001A	100 OHM 1/16 W 5% 3215 R/TP
		RA210	0RHZTCZ001A	100 OHM 1/16 W 5% 3215 R/TP
		RA212	0RHZTCZ001A	100 OHM 1/16 W 5% 3215 R/TP
		RA214	0RHZTCZ001A	100 OHM 1/16 W 5% 3215 R/TP
		RA216	0RHZTCZ001A	100 OHM 1/16 W 5% 3215 R/TP
		RA218	0RHZTCZ001A	100 OHM 1/16 W 5% 3215 R/TP
		RA220	0RHZTCZ001A	100 OHM 1/16 W 5% 3215 R/TP
		RA222	0RHZTCZ001A	100 OHM 1/16 W 5% 3215 R/TP
		RA224	0RHZTCZ001A	100 OHM 1/16 W 5% 3215 R/TP
		RA225	0RHZTCZ001A	100 OHM 1/16 W 5% 3215 R/TP
		RA226	0RHZTCZ001A	100 OHM 1/16 W 5% 3215 R/TP
		RA227	0RHZTCZ001A	100 OHM 1/16 W 5% 3215 R/TP
		RA228	0RHZTCZ001A	100 OHM 1/16 W 5% 3215 R/TP
		RA229	0RHZTCZ001A	100 OHM 1/16 W 5% 3215 R/TP
		RA230	0RHZTCZ001A	100 OHM 1/16 W 5% 3215 R/TP
		RA231	0RHZTCZ001A	100 OHM 1/16 W 5% 3215 R/TP
		RA232	0RHZTCZ001A	100 OHM 1/16 W 5% 3215 R/TP
		RA233	0RHZTCZ001A	100 OHM 1/16 W 5% 3215 R/TP
		RA234	0RHZTCZ001A	100 OHM 1/16 W 5% 3215 R/TP
		RA235	0RHZTCZ001A	100 OHM 1/16 W 5% 3215 R/TP
		RA236	0RHZTCZ001A	100 OHM 1/16 W 5% 3215 R/TP
		RA237	0RHZTCZ001A	100 OHM 1/16 W 5% 3215 R/TP
		RA238	0RHZTCZ001A	100 OHM 1/16 W 5% 3215 R/TP
		RA239	0RHZTCZ001A	100 OHM 1/16 W 5% 3215 R/TP
		RA240	0RHZTCZ001A	100 OHM 1/16 W 5% 3215 R/TP
		RA241	0RHZTCZ001A	100 OHM 1/16 W 5% 3215 R/TP
		RA242	0RHZTCZ001A	100 OHM 1/16 W 5% 3215 R/TP
OTHERs				
		J802	6612TAH003A	DJ-023 KSD R/ANGLE LB563B
		X201	6202TST001E	SX-1 SUNNY CHIP 24MHZ 30PPM
		X501	6202TST001E	SX-1 SUNNY CHIP 24MHZ 30PPM
POWER BOARD				
		C901	0CBZTBU002B	BULK PCX2 335 474K
		C902	0CKZTBU003B	SC E 332M 12.5BW7 250V BK7.5

*S	*AL	LOC. NO.	PART NO.	DESCRIPTION / SPECIFICATION
		R18	0RJ0471D677	4.7 OHM 1/10 W 5% 1608 R/TP
		R19	0RJ3002D677	30000 OHM 1/10 W 5% 1608 R/T
		R20	0RJ3602D677	36K OHM 1/10 W 5% 1608 R/TP
		R21	0RH0101D622	1.0 1/10W 5 TA
		R22	0RJ1002D677	10K OHM 1/10 W 5% 1608 R/TP
		R23	0RJ3602D677	36K OHM 1/10 W 5% 1608 R/TP
		R24	0RH0101D622	1.0 1/10W 5 TA
		R26	0RJ4702D677	47000 OHM 1/10 W 5% 1608 R/T
		R29	0RJ1502D677	15K OHM 1/10 W 5% 1608 R/TP
		R30	0RJ1502D677	15K OHM 1/10 W 5% 1608 R/TP
		R32	0RJ1000D677	100 OHM 1/10 W 5% 1608 R/TP
		R33	0RJ1000D677	100 OHM 1/10 W 5% 1608 R/TP
		R69	0RJ1000D677	100 OHM 1/10 W 5% 1608 R/TP
		J1	6612TAH003A	DJ-023 KSD R/ANGLE LB563B
		J4	6612F00001C	DJ-S360LB KSD STERO R/A LIGH
		J6	6612F00005D	DJ-SW3P-LM KSD STERO R/A LIM
		L2	150-985J	DR10*12 2MH 0.28MM 220.5T R/
		LED1	ODLLT0130AA	LITEON LTL-4231HNBP BK GREEN
		S1	140-058B	EVQ PB2 05K MATUSHITA NON 12
		S2	140-058B	EVQ PB2 05K MATUSHITA NON 12
		S3	140-058B	EVQ PB2 05K MATUSHITA NON 12

CONTROL BOARD

		LED1	0DLRH0058AA	ROHM SML-521MYWT86 R/TP GREE
		R1	0RJ4701D677	4.7K OHM 1/10 W 5% 1608 R/TP
		R2	0RJ4701D677	4.7K OHM 1/10 W 5% 1608 R/TP
		R3	0RH8200D622	820 1/10W 5 D.R/TP
		R4	0RH8200D622	820 1/10W 5 D.R/TP
		R5	0RJ1501D677	1.5K OHM 1/10 W 5% 1608 R/TP
		R6	0RJ1501D677	1.5K OHM 1/10 W 5% 1608 R/TP
		R7	0RJ2201D677	2200 OHM 1/10 W 5% 1608 R/TP
		R8	0RJ2201D677	2200 OHM 1/10 W 5% 1608 R/TP
		R10	0RJ0000D677	0 OHM 1/10 W 5% 1608 R/TP
		R11	0RJ0000D677	0 OHM 1/10 W 5% 1608 R/TP
		R12	0RJ0000D677	0 OHM 1/10 W 5% 1608 R/TP
		R13	0RJ0000D677	0 OHM 1/10 W 5% 1608 R/TP
		R14	0RJ0000D677	0 OHM 1/10 W 5% 1608 R/TP
		SW1	6600R000002	SKQRAAE010 J-ALPS 12V DC 50M
		SW2	6600R000002	SKQRAAE010 J-ALPS 12V DC 50M
		SW3	6600R000002	SKQRAAE010 J-ALPS 12V DC 50M
		SW4	6600R000002	SKQRAAE010 J-ALPS 12V DC 50M
		SW5	6600R000002	SKQRAAE010 J-ALPS 12V DC 50M
		SW6	6600R000002	SKQRAAE010 J-ALPS 12V DC 50M
		SW7	6600R000002	SKQRAAE010 J-ALPS 12V DC 50M
		SW8	6600R000002	SKQRAAE010 J-ALPS 12V DC 50M

USB BOARD

		C1	0CH8107F611	100UF 16V M 85STD(CYL) R/TP
		C2	0CK103CK51A	0.01UF 1608 50V 10% R/TP B(Y
		C6	0CH3105F946	1UF 16V Z F 2012 R/TP
		C8	0CC150CK41A	15PF 1608 50V 5% R/TP NP0
		C9	0CC150CK41A	15PF 1608 50V 5% R/TP NP0
		C18	0CK104CK56A	0.1UF 1608 50V 10% R/TP X7R
		C23	0CH8107F611	100UF 16V M 85STD(CYL) R/TP
		C24	0CC470CK41A	47PF 1608 50V 5% R/TP NP0
		C25	0CC470CK41A	47PF 1608 50V 5% R/TP NP0
		C27	0CH8107F611	100UF 16V M 85STD(CYL) R/TP
		C28	0CK103CK51A	0.01UF 1608 50V 10% R/TP B(Y
		C31	0CK104CK56A	0.1UF 1608 50V 10% R/TP X7R
		C32	0CK104CK56A	0.1UF 1608 50V 10% R/TP X7R

*S	*AL	LOC. NO.	PART NO.	DESCRIPTION / SPECIFICATION
		C37	0CH8107F611	100UF 16V M 85STD(CYL) R/TP
		C38	0CC470CK41A	47PF 1608 50V 5% R/TP NP0
		C39	0CC470CK41A	47PF 1608 50V 5% R/TP NP0
		D1	0DS181009AA	KDS181 TP KEC SOT-23 80V 3
		ZD1	0DZ560009DA	UDZ S 5.6B TP ROHM-K SOD323
		ZD4	0DZ560009DA	UDZ S 5.6B TP ROHM-K SOD323
		ZD7	0DZ560009DA	UDZ S 5.6B TP ROHM-K SOD323
		ZD8	0DZ560009DA	UDZ S 5.6B TP ROHM-K SOD323
		ZD11	0DZ560009DA	UDZ S 5.6B TP ROHM-K SOD323
		ZD12	0DZ560009DA	UDZ S 5.6B TP ROHM-K SOD323
		U1	0IRH033200A	BA033FP-E2 MOLD-3 TP REGULAT
		U2	0IPRPT1007A	TUSB2036 TEXAS INSTRUMENT 32
		U3	0ITI204200B	TPS2042ADR TEXAS INSTRUMENT
		L4	6210TCE001P	HB-1S2012-121JT CERATECH 201
		L5	6210TCE001P	HB-1S2012-121JT CERATECH 201
		L13	6210TCE001B	HH-1H3216-500JT CERATEC 3216
		L14	6210TCE001P	HB-1S2012-121JT CERATECH 201
		L15	6210TCE001P	HB-1S2012-121JT CERATECH 201
		L16	6210TCE001P	HB-1S2012-121JT CERATECH 201
		L17	6210TCE001P	HB-1S2012-121JT CERATECH 201
		L18	6210TCE001B	HH-1H3216-500JT CERATEC 3216
		L19	6210TCE001P	HB-1S2012-121JT CERATECH 201
		L20	6210TCE001P	HB-1S2012-121JT CERATECH 201
		R1	0RJ0000D677	0 OHM 1/10 W 5% 1608 R/TP
		R2	0RJ1001D677	1K OHM 1/10 W 5% 1608 R/TP
		R8	0RJ1002D677	10K OHM 1/10 W 5% 1608 R/TP
		R9	0RJ1501D677	1.5K OHM 1/10 W 5% 1608 R/TP
		R19	0RJ1502D677	15K OHM 1/10 W 5% 1608 R/TP
		R21	0RJ0222D677	22 OHM 1/10 W 5% 1608 R/TP
		R22	0RJ0222D677	22 OHM 1/10 W 5% 1608 R/TP
		R23	0RJ1502D677	15K OHM 1/10 W 5% 1608 R/TP
		R24	0RJ1502D677	15K OHM 1/10 W 5% 1608 R/TP
		R25	0RJ0000D677	0 OHM 1/10 W 5% 1608 R/TP
		R26	0RJ1002D677	10K OHM 1/10 W 5% 1608 R/TP
		R28	0RJ0222D677	22 OHM 1/10 W 5% 1608 R/TP
		R30	0RJ0222D677	22 OHM 1/10 W 5% 1608 R/TP
		R31	0RJ1502D677	15K OHM 1/10 W 5% 1608 R/TP
		R32	0RJ1502D677	15K OHM 1/10 W 5% 1608 R/TP
		R34	0RJ0222D677	22 OHM 1/10 W 5% 1608 R/TP
		R35	0RJ0222D677	22 OHM 1/10 W 5% 1608 R/TP
		R37	0RJ1501D677	1.5K OHM 1/10 W 5% 1608 R/TP
		R40	0RJ1501D677	1.5K OHM 1/10 W 5% 1608 R/TP
		R41	0RJ1002D677	10K OHM 1/10 W 5% 1608 R/TP
		X1	6202TST001C	SX-1, SUNNY SMD, 6.0MHZ .50P

PIN CONFIGURATION

GM5020

GENESIS 292P

FUNCTIONAL BLOCK DIAGRAM

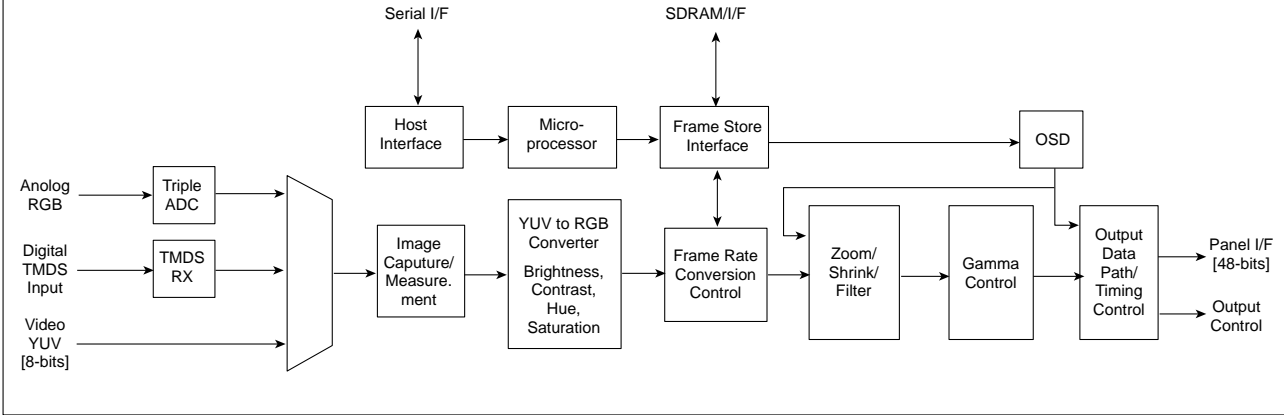

SYSTEM BLOCK DIAGRAM

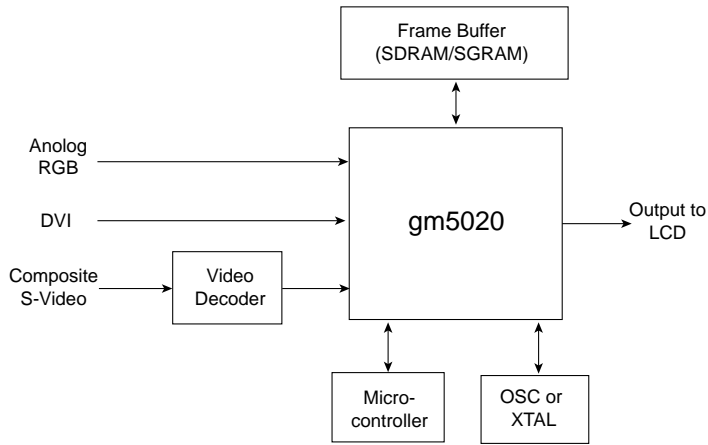

74F08D 14P

SOP TP QUAD 2-INPUT

PIN FUNCTION

INPUT		OUTPUT
Dna	Dnb	Qn
L	L	L
L	H	L
H	L	L
H	H	H

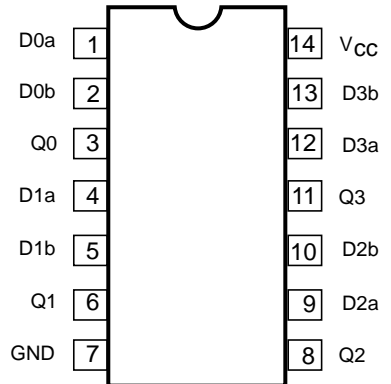

PIN CONFIGURATION

CAT24WC08J-TE13 8P

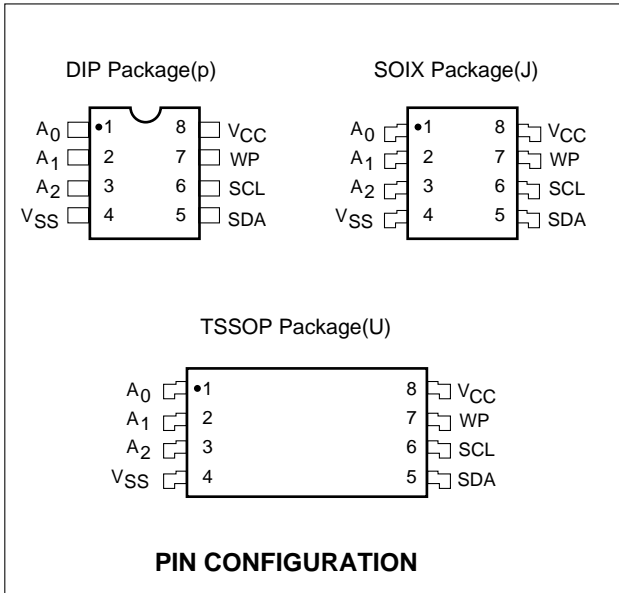

PIN FUNCTION

Pin Name	Function
A0, A1, A2	Device Address Inputs
SDA	Serial Data/Address
SCL	Serial Clock
WP	Write Protect
Vcc	+1.8V to +6.0V power Supply
Vss	Ground

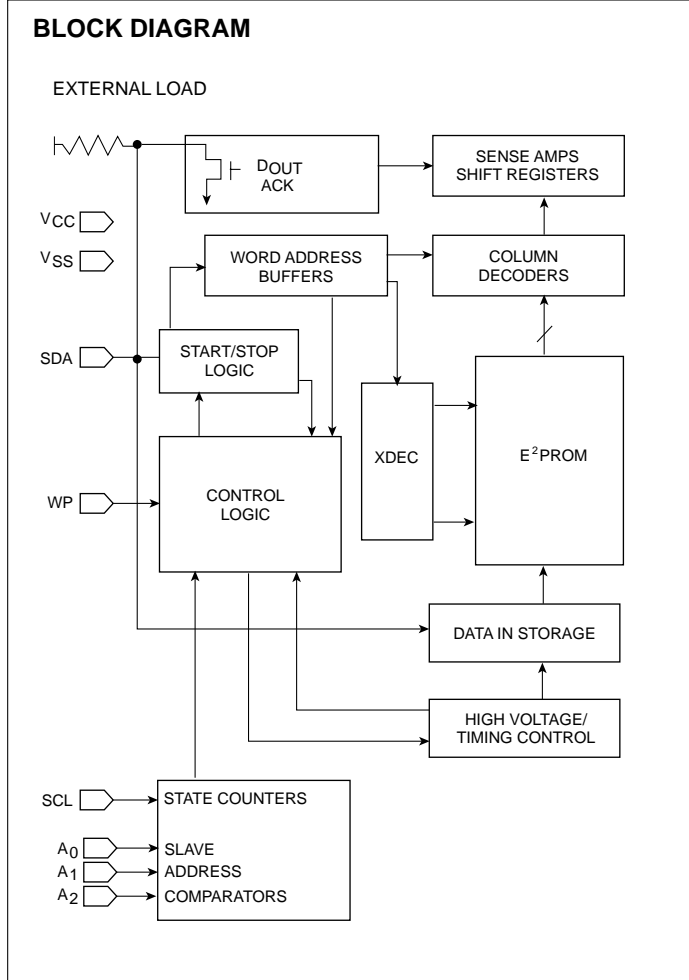

MC74HCT14ADR2 14P

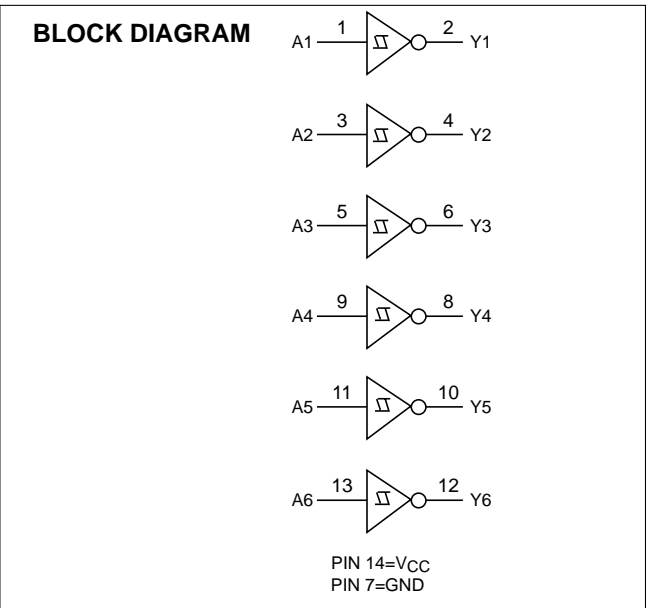
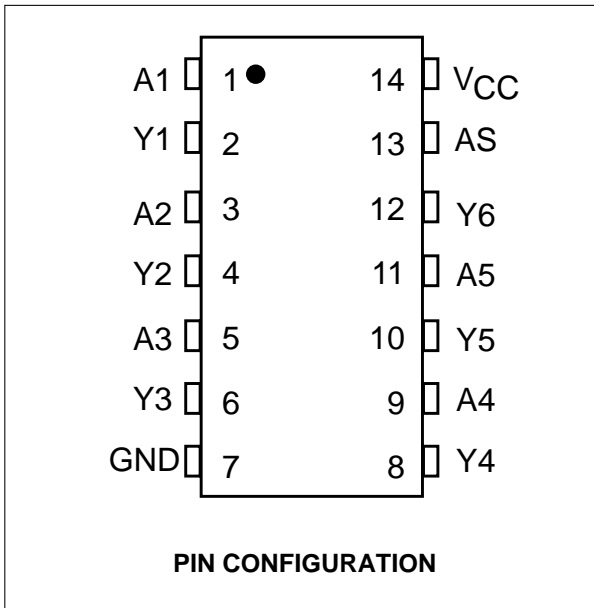

S524C20D11/20D21/80D41/80D81 SERIAL EEPROM

PIN FUNCTION

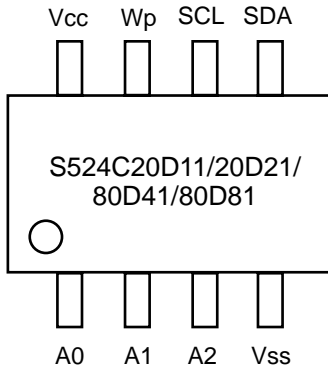

PIN CONFIGURATION

Name	Type	Description	Circuit Type
A0, A1, A2	Input	Input pins for device address selection. To configure a device address, these pins should be connected to the Vcc or Vss of the device.	1
Vss	-	Ground pin.	-
SDA	I/O	Bi-directional data pin for the I ² C-bus serial data interface. Schmitt trigger input and open-drain output. An external pull-up resistor must be connected to Vcc. Typical values for this pull-up resistor are 4.7k (100kHz) and 1k (400kHz).	3
SCL	Input	Schmitt trigger input pin for serial clock input.	2
SDA	I/O	Input pin for hardware write protection control. If you tie this pin to Vcc, the write function is disabled to protect previously written data in the entire memory; if you tie it to Vss, the write function is enabled.	1
Vcc	-	Single power supply.	-

NOTE: See following page for diagrams of pin circuit types 1,2 and 3.

BLOCK DIAGRAM

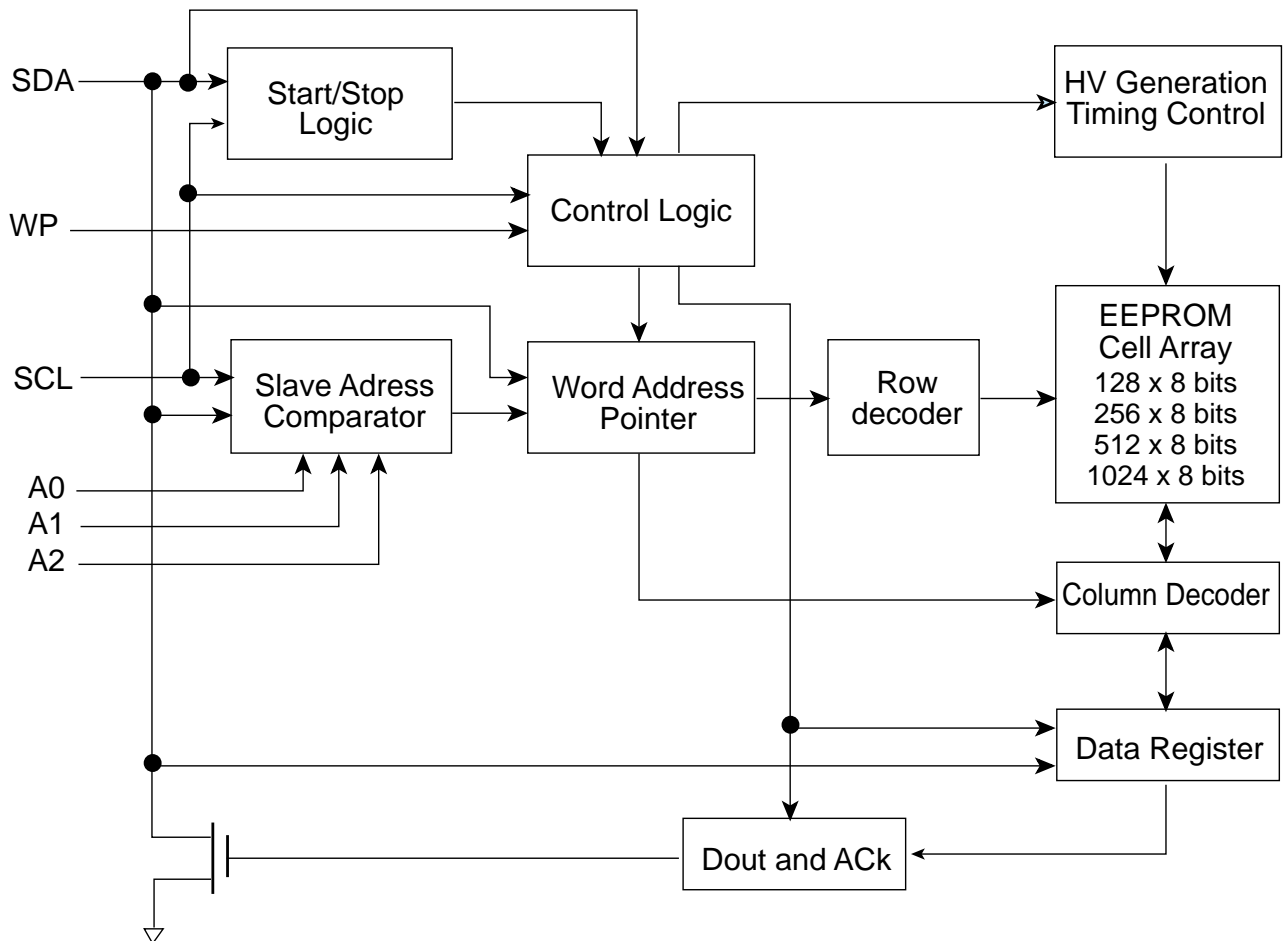

#1 GM5020

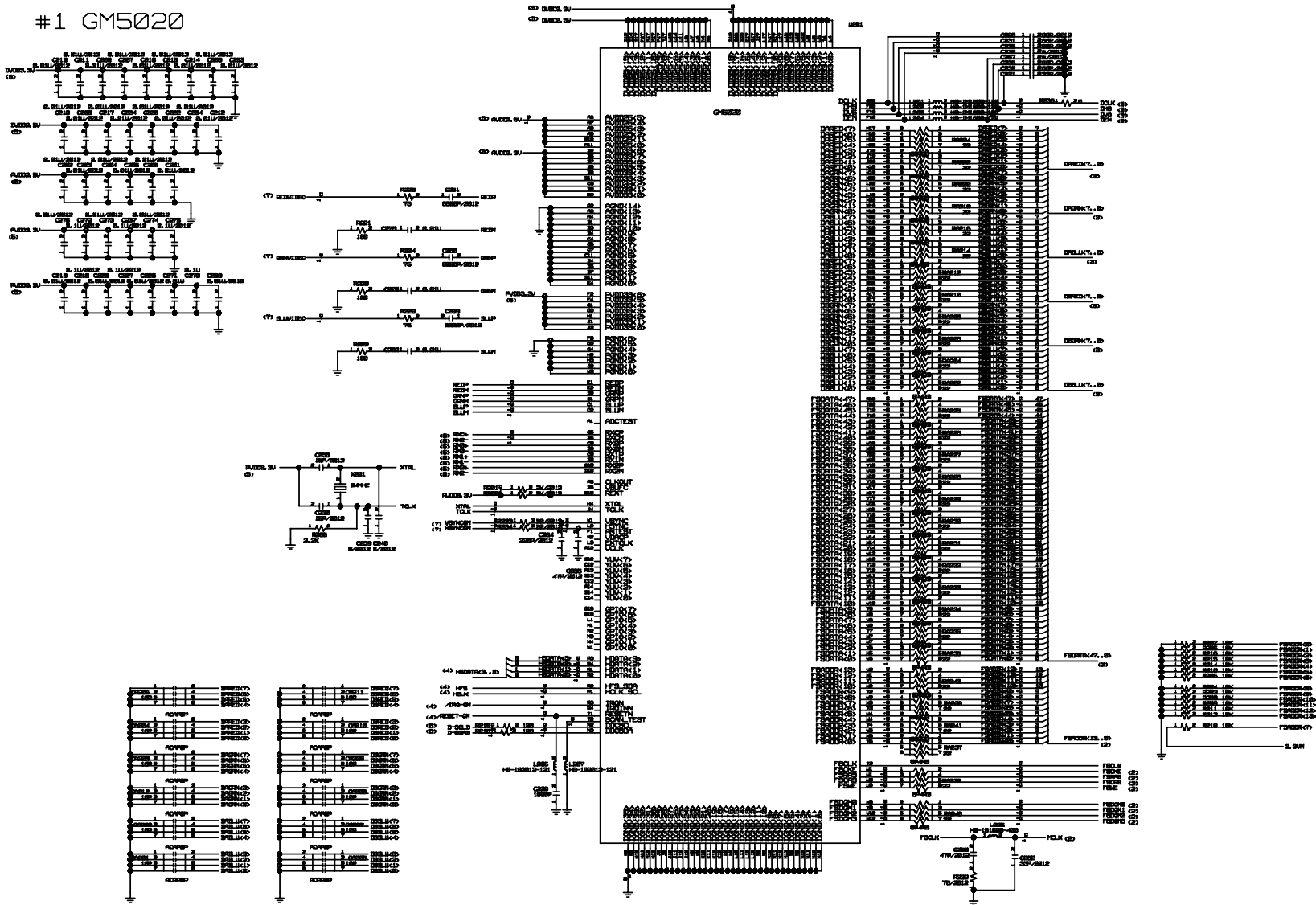

#2 MEMORY

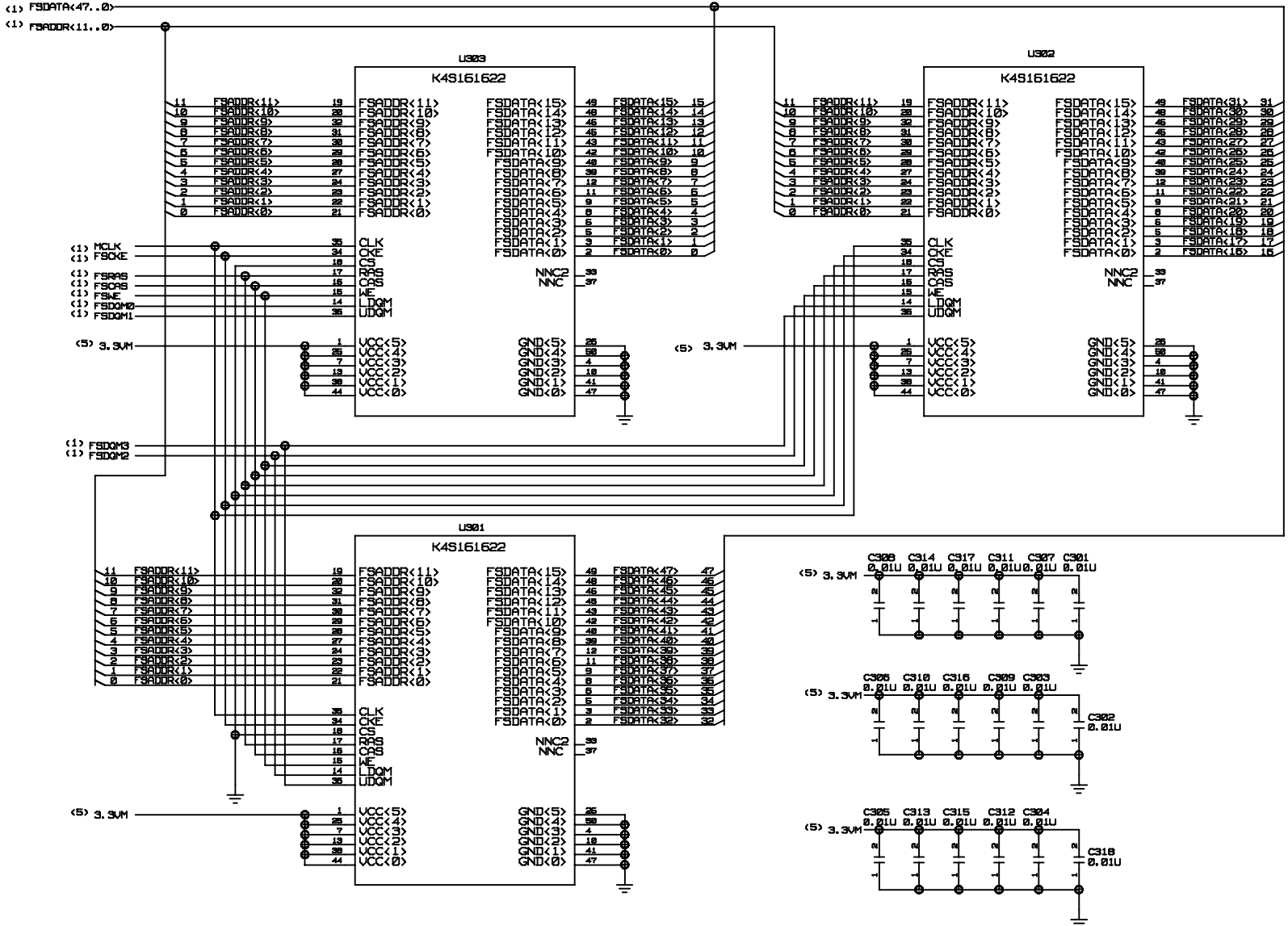

#3 LVDS

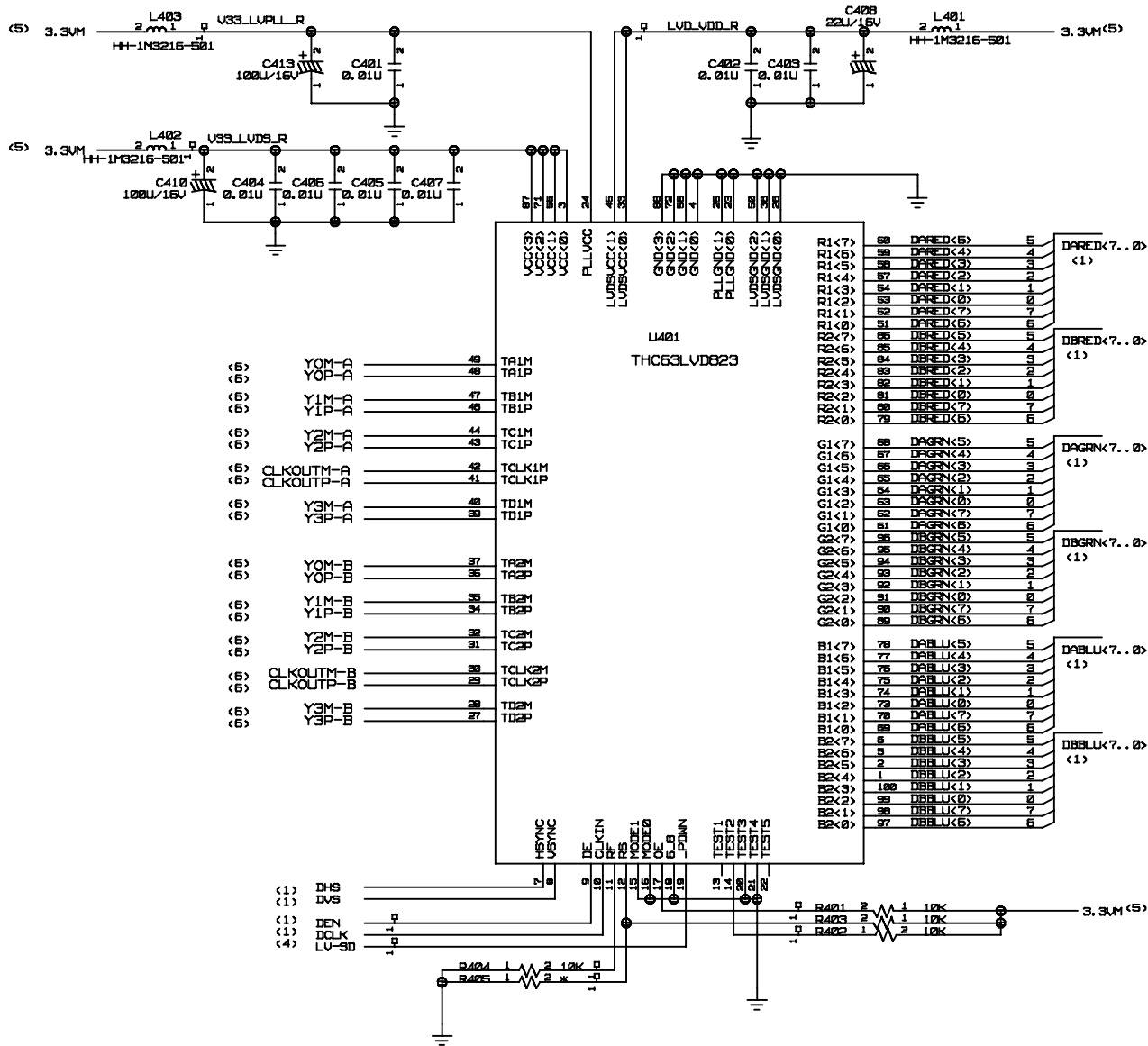

3. LVDS

#4 MICOM

4. MICOM

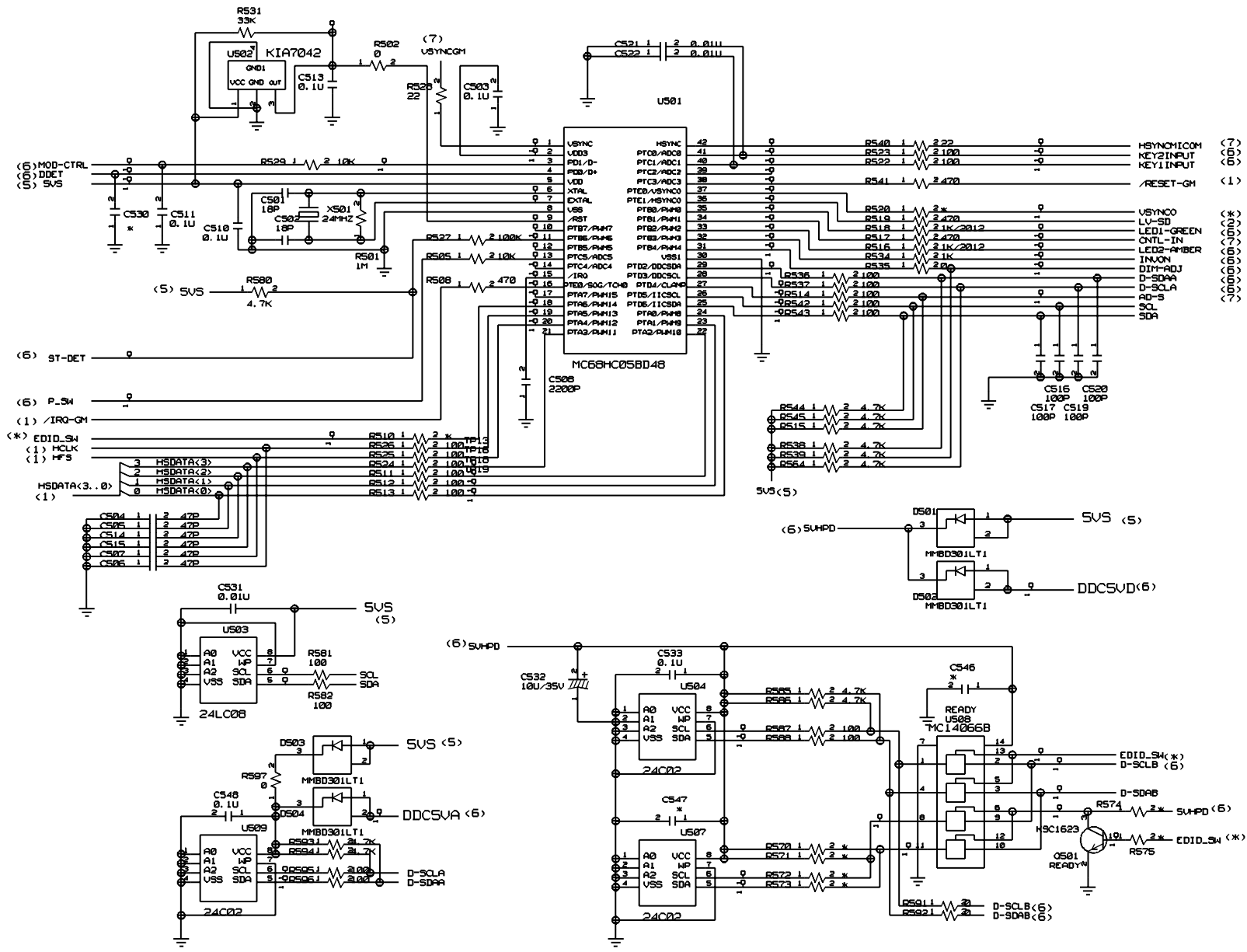

#5 DC/DC

5. DC/DC

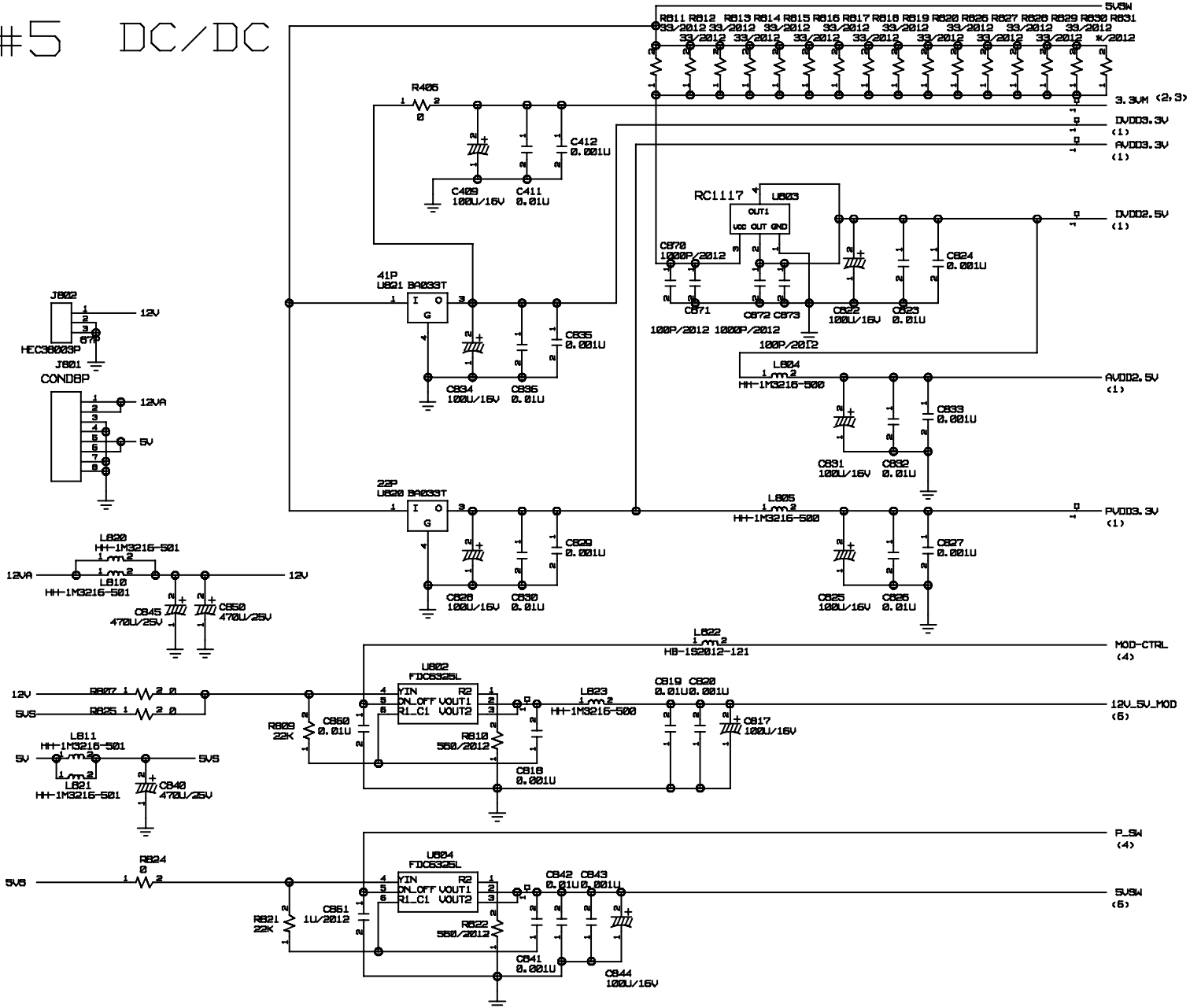

#6 CONNECTOR

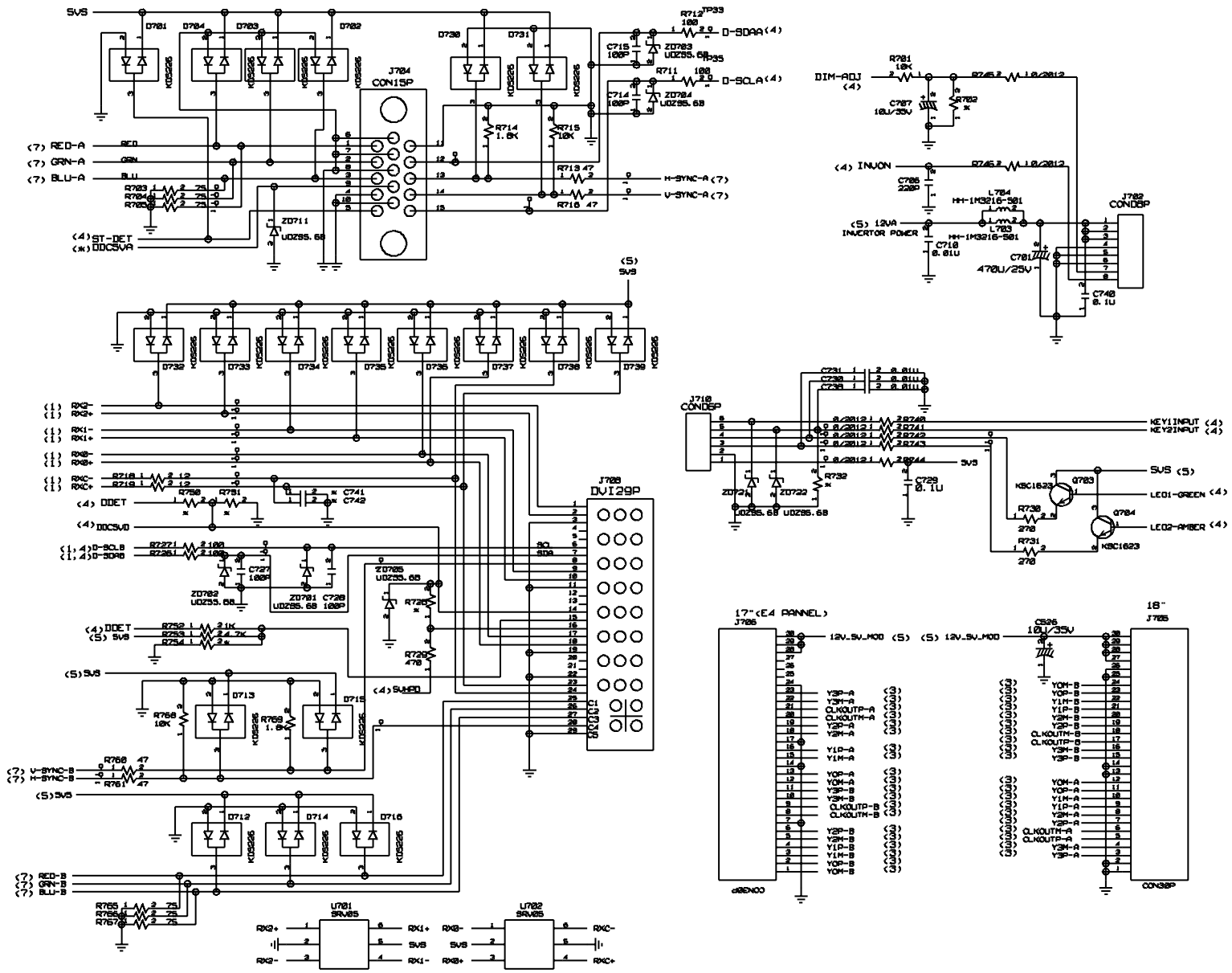

6. CONNECTOR

#7 INPUT SWITCHING

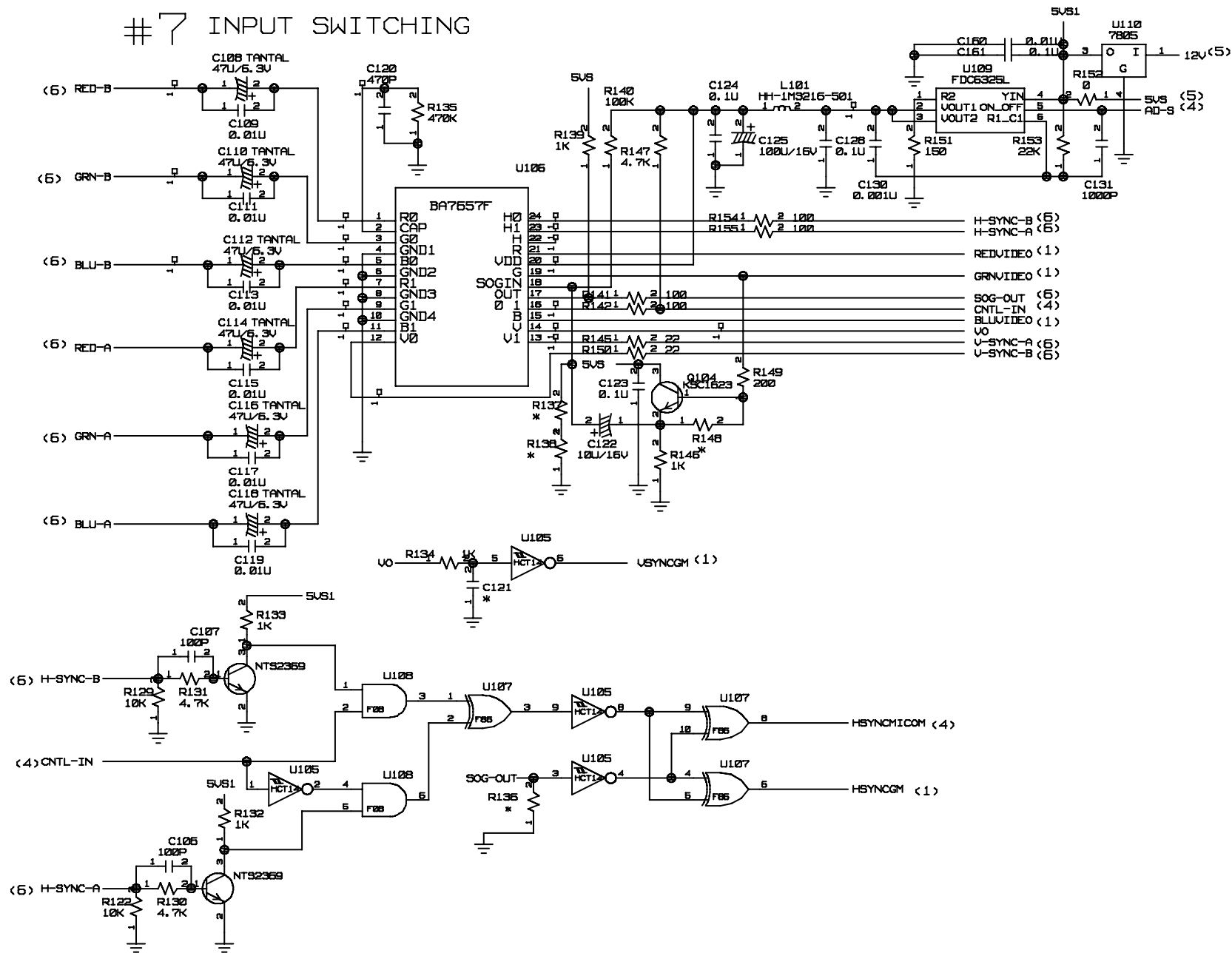

7. INPUT SWITCHING

8. CONTROL KEY

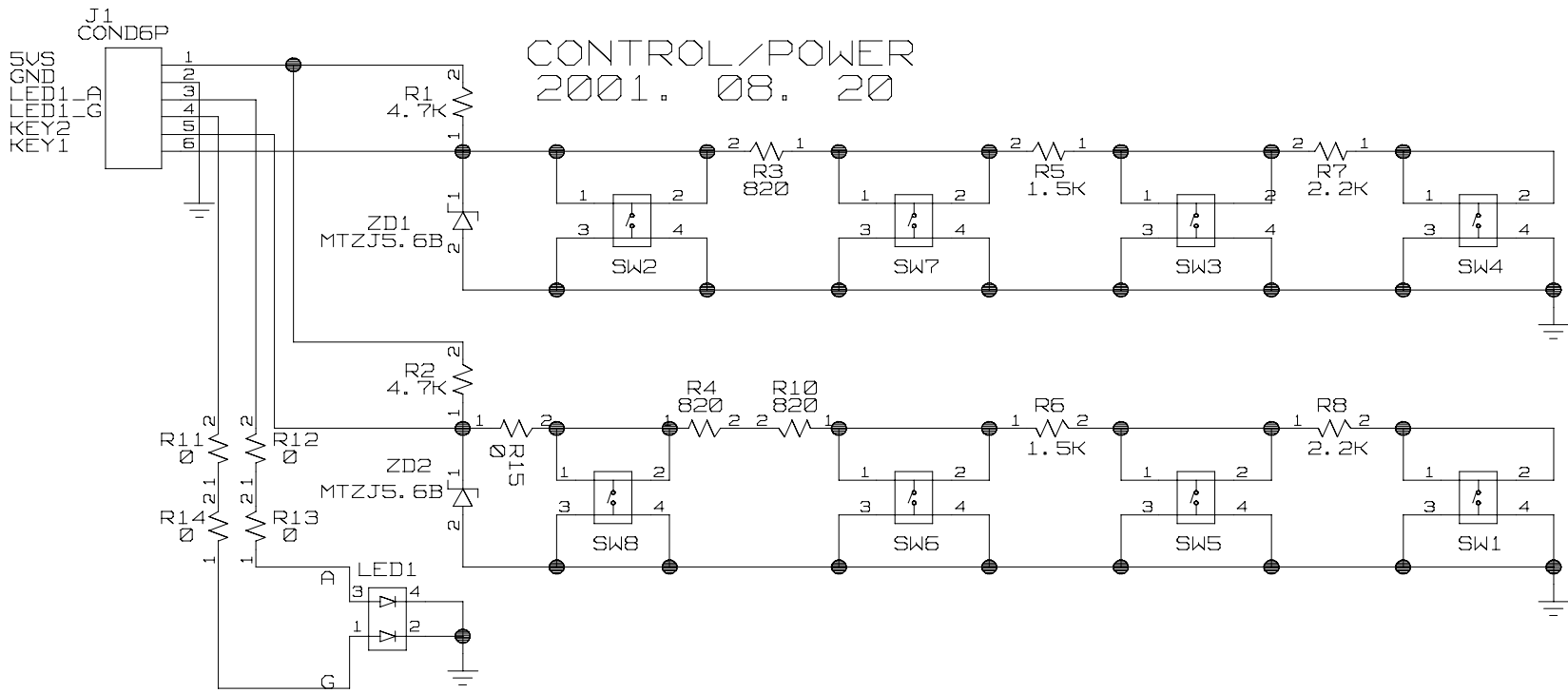

9.USB

1 LB886F USB
2001.11.12

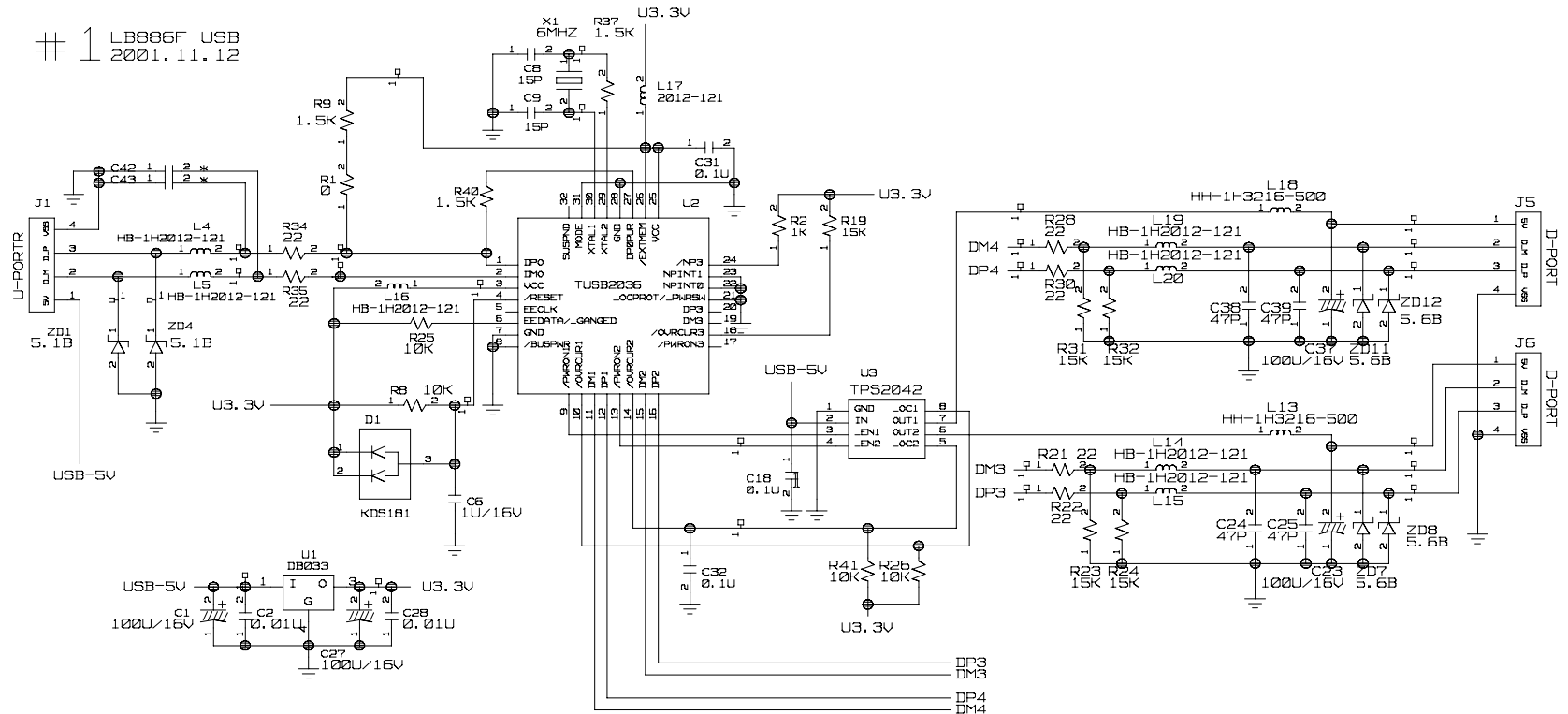

LB886F Internal Power Circuit

2001.11.21

10. POWER

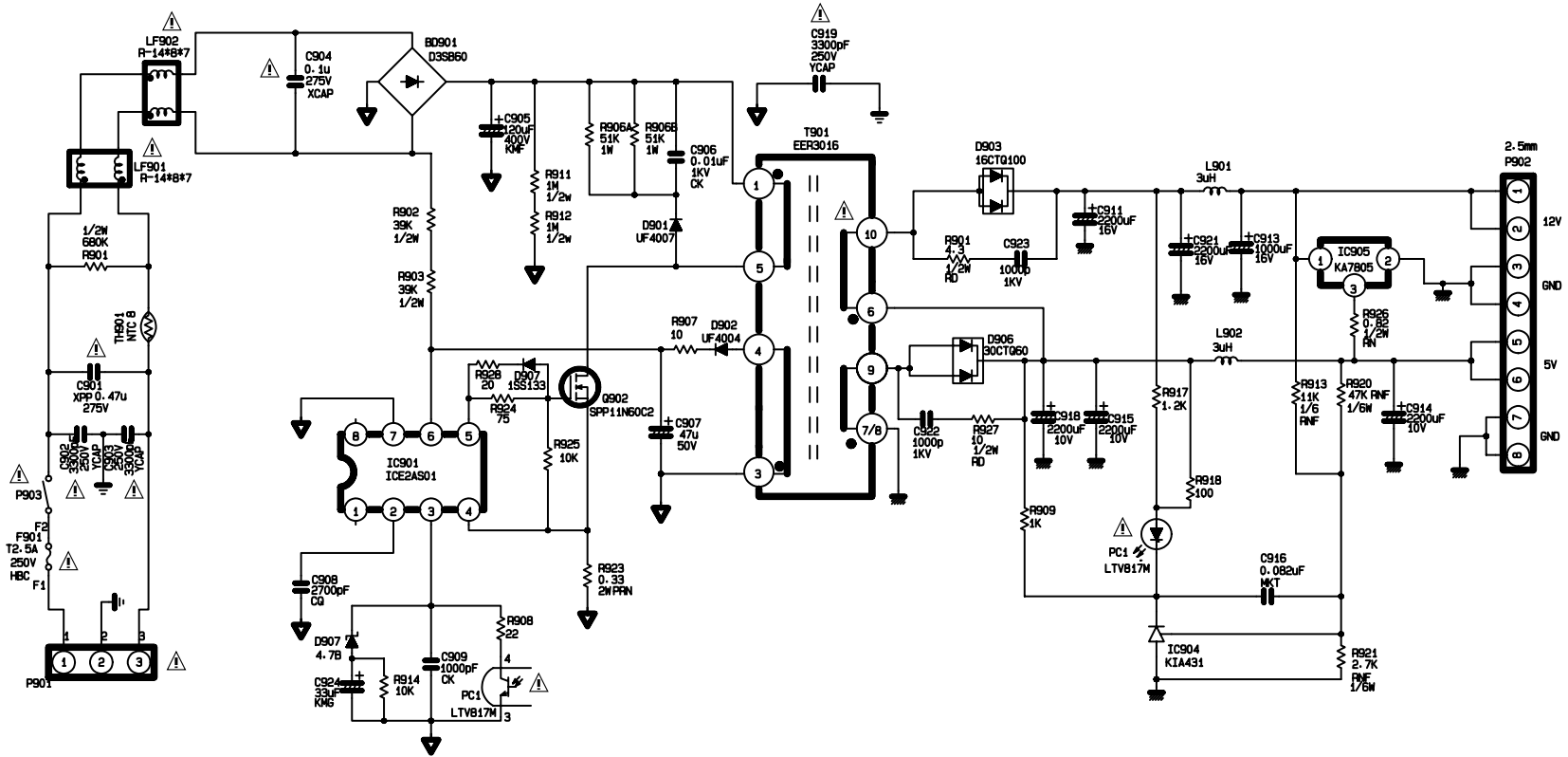

1 LB886F AUDIO
2002.02.01

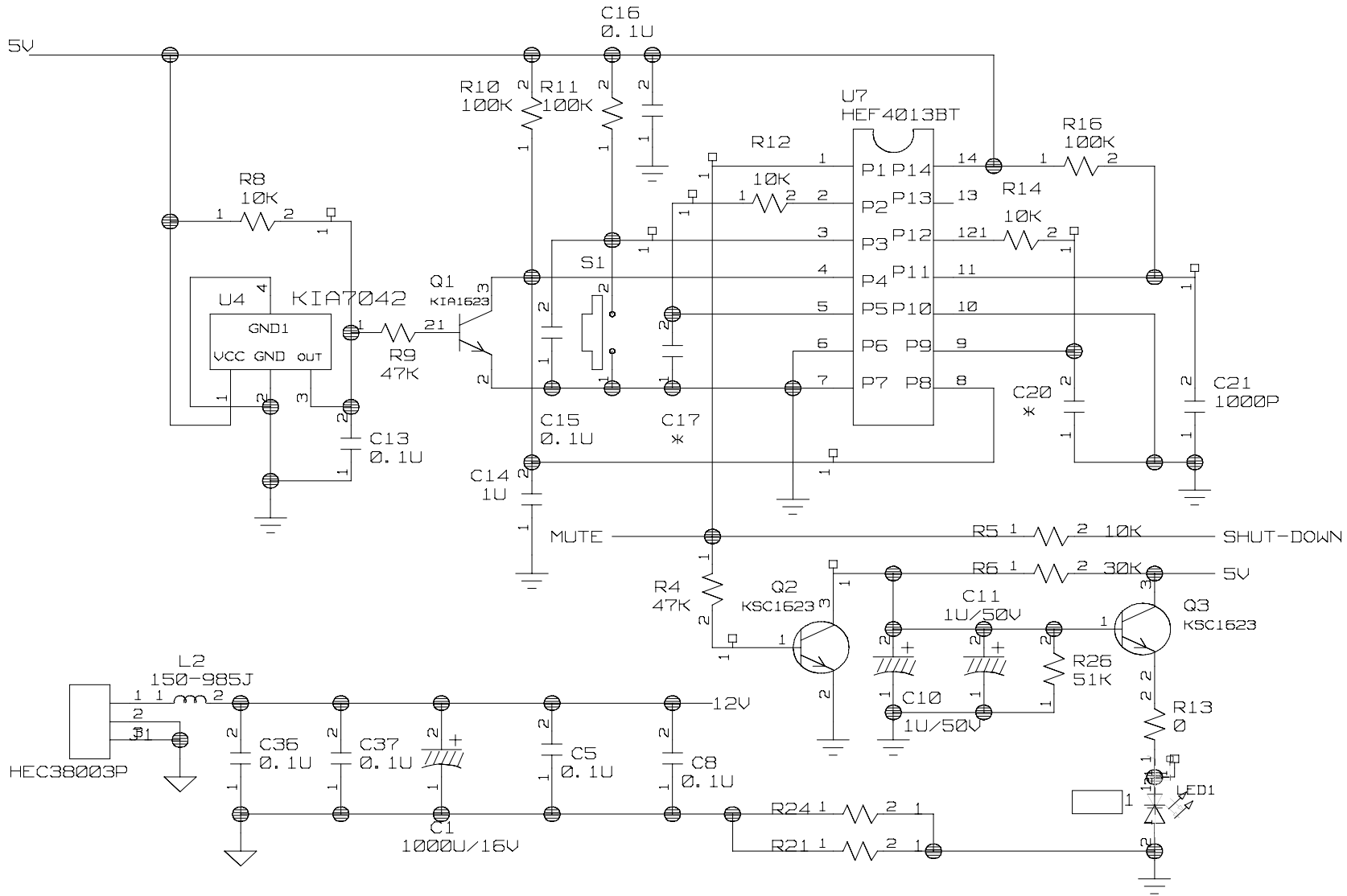

12. AUDIO

LB886F AUDIO
2002.02.01

