

Phase Control Circuit for Current Feedback

Description

The U2010B is designed as a phase-control circuit in bipolar technology. It enables load-current detection and has a soft-start function as well as reference voltage

output. Motor control with load-current feedback and overload protection are preferred applications.

Features

- Full wave current sensing
- Mains supply variation compensated
- Programmable load-current limitation with over- and high-load output
- Variable soft-start
- Voltage and current synchronization
- Automatic retriggering switchable
- Triggering pulse typical 125 mA

- Internal supply voltage monitoring
- Current requirement ≤ 3 mA
- Temperature compensated reference voltage

Applications

- Advanced motor control
- Grinder
- Drilling machine

Package: DIP16, SO16

Block Diagram

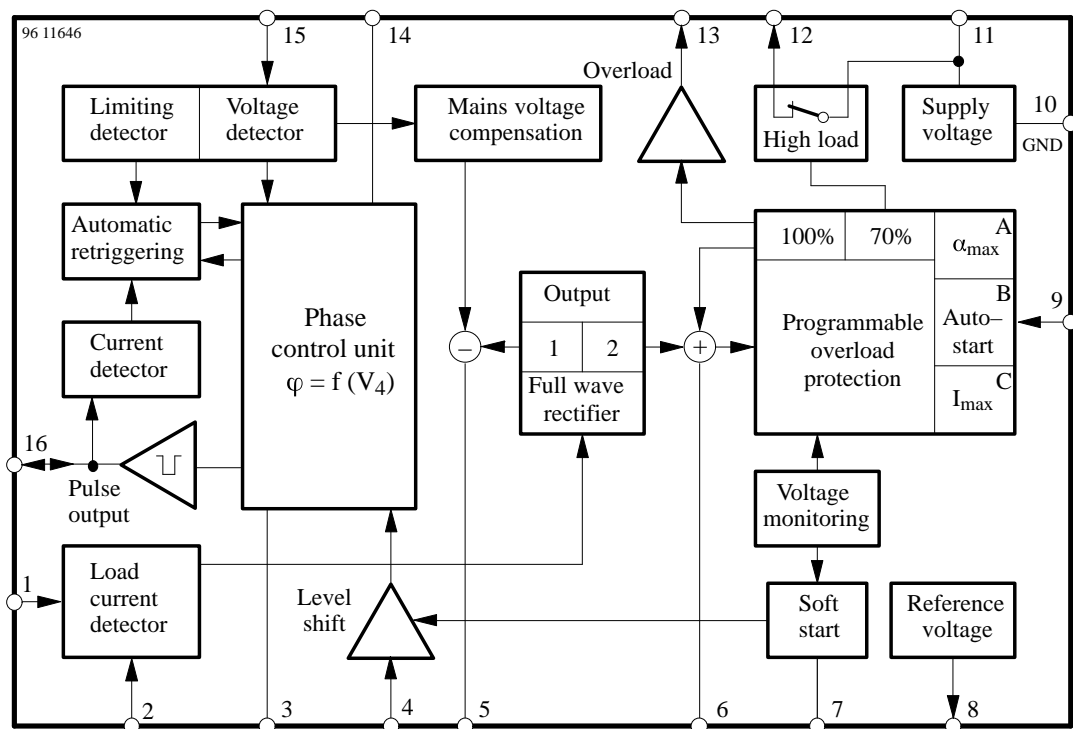

Figure 1. Block diagram

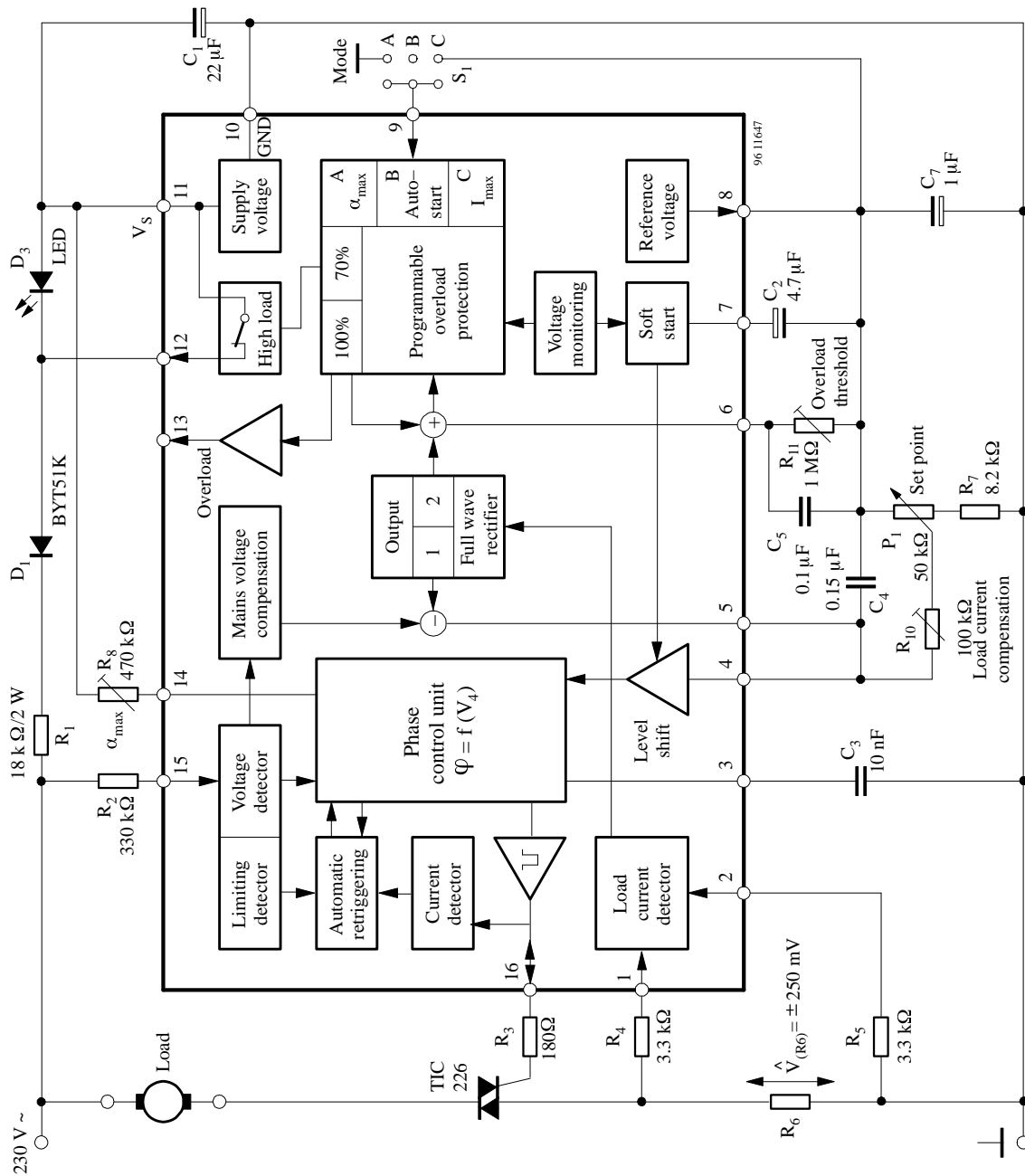

Figure 2. Block diagram with external circuit

General Description

Mains Supply

The U2010B contains voltage limiting and can be connected with the mains supply via D_1 and R_1 . Supply voltage – between Pin 10 and Pin 11 – is smoothed by C_1 .

In the case of $V_6 \leq (70\% \text{ of overload threshold voltage})$, Pins 11 and 12 are connected internally whereby $V_{sat} \leq 1.2$ V. When $|V_6| \geq |V_{T70}|$ the supply current flows across D_3 .

Pin Description

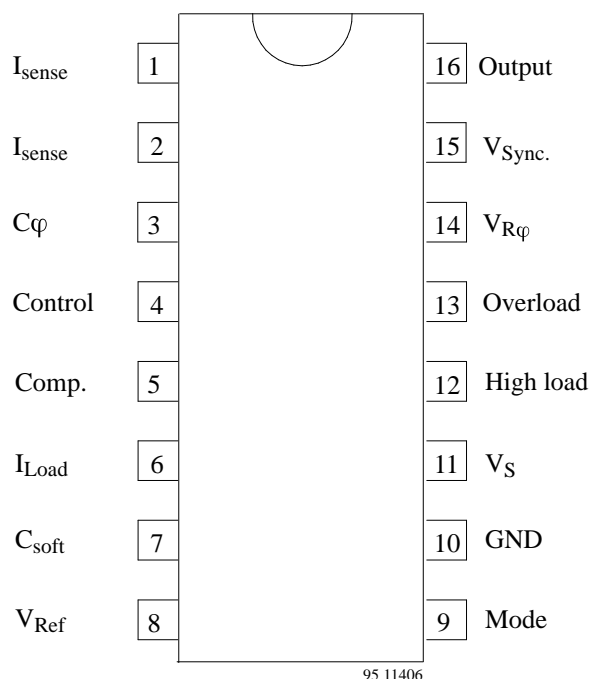

Pin	Symbol	Function
1	I_{sense}	Load current sensing
2	I_{sense}	Load current sensing
3	C_{ϕ}	Ramp voltage
4	Control	Control input
5	Comp.	Compensation output
6	I_{Load}	Load current limitation
7	C_{soft}	Soft start
8	V_{Ref}	Reference voltage
9	Mode	Mode selection
10	GND	Ground
11	V_S	Supply voltage
12	High load	High load indication
13	Overload	Overload indication
14	$V_{R\phi}$	Ramp current adjust
15	$V_{Sync.}$	Voltage synchronization
16	Output	Trigger output

Series resistance R_1 can be calculated as follows:

$$R_{1max} = \frac{V_{mains} - V_{Smax}}{2 \times I_{tot}} \text{ whereas}$$

- V_{mains} = Mains supply voltage
- V_{Smax} = Maximum supply voltage
- I_{tot} = Total current consumption = $I_{Smax} + I_x$
- I_{Smax} = Maximum current consumption of the IC
- I_x = Current consumption of the external components

Voltage Monitoring

As the voltage is built up, uncontrolled output pulses are avoided by internal voltage monitoring. Apart from that all the latches in the circuit (phase control, load limit regulation) are reset and the soft-start capacitor is short circuited. This guarantees a specified start-up behavior each time the supply voltage is switched on or after short interruptions of the mains supply. Soft-start is initiated after the supply voltage has been built up. This behavior guarantees a gentle start-up for the motor and automatically ensures the optimum run-up time.

Phase Control

The function of the phase control is largely identical to the well known IC family U211B. The phase angle of the trigger pulse is derived by comparing the ramp voltage V_3 which is mains synchronized by the voltage detector with the set value on the control input, Pin 4. The slope of the

ramp is determined by C_{ϕ} and its charging current I_{ϕ} . The charging current can be varied using R_{ϕ} at Pin 14. The maximum phase angle, α_{max} , can also be adjusted by using R_{ϕ} (minimum current flow angle ϕ_{min}) see figure 4.

When the potential on Pin 3 reaches the set point level of Pin 4, a trigger pulse width, t_p , is determined from the value of C_{ϕ} ($t_p = 9 \mu s/nF$). At the same time, a latch is set with the output pulse, as long as the automatic retriggering has not been activated, then no more pulses can be generated in that half cycle. Control input at Pin 4 (with respect to Pin 10) has an active range from V_8 to -1 V. When $V_4 = V_8$, then the phase angle is at its maximum, α_{max} , i.e., the current flow angle is minimum. The minimum phase angle, α_{min} , is set with $V_4 \geq -1$ V.

Automatic Retriggering

The current-detector circuit monitors the state of the triac after triggering by measuring the voltage drop at the triac gate. A current flow through the triac is recognized, when the voltage drop exceeds a threshold level of typ. 40 mV.

If the triac is quenched within the relevant half-wave after triggering; for example owing to low load currents before or after the zero crossing of current wave or; for commutator motors, owing to brush lifters. Then the automatic retriggering circuit ensures immediate retriggering, if necessary with a high repetition rate, t_{pp}/t_p , until the triac remains reliably triggered.

Current Synchronization

Current synchronization fulfils two functions:

- Monitoring the current flow after triggering.
In case the triac extinguishes again or it does not switch on, automatic triggering is activated until the triggering is successful.
- Avoiding a triggering due to inductive load.
In the case of inductive load operation the current synchronization ensures that in the new half wave no pulse is enabled as long as there is a current available which from the previous half-wave, which flows from the opposite polarity to the actual supply voltage.

A special feature of the integrated circuit is the realization of this current synchronization. The device evaluates the voltage at the pulse output between gate and reference electrode of the triac. This results in saving separate current synchronization input with specified series resistance.

Voltage Synchronization with Mains Voltage Compensation

The voltage detector synchronizes the reference ramp with the mains-supply voltage. At the same time, the mains dependent input current at Pin 15 is shaped and rectified internally. This current activates the automatic retriggering and at the same time is available at Pin 5. By suitable dimensioning, it is possible to attain the specified compensation effect. Automatic retriggering and mains voltage compensation are not activated until $|V_{15} - 10|$ increases to 8 V. Resistance, R_{sync} , defines the width of the zero voltage cross over pulse, synchronization current, and hence the mains supply voltage compensation current.

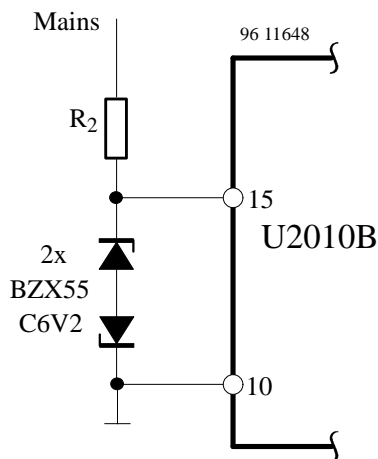

Figure 3.

If the mains voltage compensation and the automatic retriggering are not required, both functions can be suppressed by limiting $|V_{15} - 10| \leq 7 \text{ V}$ (figure 3).

Load Current Compensation

The circuit continuously measures the load current as a voltage drop at resistance R_6 . The evaluation and use of both half waves results in a quick reaction to load current change. Due to voltage at resistance R_6 , there is a difference between both input currents at Pins 1 and 2. This difference controls the internal current source, whose positive current values are available at Pins 5 and 6. The output current generated at Pin 5 contains the difference from the load-current detection and from the mains-voltage compensation (see figure 1).

The effective control voltage at Pin 4 is the final current at Pin 5 together with the desired value network. An increase of mains voltage causes the increase of control angle α , an increase of load current results in a decrease in the control angle. This avoiding a decrease in revolution by increasing the load as well as the increase of revolution by the increment of mains supply voltage.

Load Current Limitation

The total output load current is available at Pin 6. It results in a voltage drop across R_{11} . When the potential of the load current reaches about 70% of the threshold value (V_{T70}) i.e., ca. 4.35 V at Pin 6, it switches the high load comparator and opens the switch between Pins 11 and 12. By using an LED between these pins, (11 and 12) a high load indication can be realized.

If the potential at Pin 6 increases to ca. 6.2 V ($= V_{T100}$), it switches the overload comparator. The result is programmable at Pin 9 (operation mode).

Mode selection:

- a) $\alpha_{max} (V_9 = 0)$
In this mode of operation, after V_6 has reached the threshold V_{T100} , Pin 13 switches to $-V_S$ (Pin 11) and Pin 6 to GND (Pin 10). A soft-start capacitor is then shorted and the control angle is switched to α_{max} . This position is maintained until the supply voltage is switched off. The motor can be started again with soft-start function when the power is switched on again. As the overload condition switches Pin 13 to Pin 11, it is possible to set in a smaller control angle, α_{max} , by connecting a further resistance between Pins 13 and 14.

b) Auto start (Pin 9 – open)

The circuit behaves as written under α_{\max} ($V_9 = 0$), with the exception that Pin 6 is not connected to GND. If the value of V_6 decreases to 25% of the threshold value (V_{T25}), the circuit becomes active again with soft-start.

c) I_{\max} ($V_9 = V_8$)

When V_6 has attained the overload threshold maximum value i.e. $V_6 = V_{T100}$; Pin 13 is switched to Pin 8 (V_{Ref}) through the resistance R ($= 2 \text{ k}\Omega$) without soft-start capacitor discharging at Pin 7. With this mode of operation, direct load current control (I_{\max}) is possible. A recommended circuit is shown in figure 18.

Absolute Maximum Ratings

Reference point Pin 10, unless otherwise specified

Parameters	Symbol	Value	Unit
Sink current Pin 11 $t \leq 10 \mu\text{s}$	$-I_S$ $-i_s$	30 100	mA
Sync. currents Pin 15 $t \leq 10 \mu\text{s}$	$\pm I_{\text{sync}V}$ $\pm I_{\text{sync}V}$	5 20	mA
Phase control			
Control voltage Pins 4 and 8	$-V_I$	$0 - V_8$	V
Input current Pin 4	$\pm I_I$	500	μA
Charging current Pin 14	$-I_{\phi \max}$	0.5	mA
Soft-start			
Input voltage Pins 7 and 8	$-V_I$	$0 - V_8$	V
Pulse output			
Input voltage Pin 16	$+V_I$ $-V_I$	2 V_{11}	V
Reference voltage source			
Output current Pin 8 $t \leq 10 \mu\text{s}$	I_0	10 30	mA
Load current sensing			
Input currents Pins 1 and 2	$\pm I_j$	1	mA
Input voltages Pins 5 and 6	$-V_i$	$0 - V_8$	V
Overload output Pin 13	I_L	1	mA
High-load output Pin 12 $t \leq 10 \mu\text{s}$	I_L	30 100	mA
Storage temperature range	T_{stg}	$-40 \text{ to } +125$	$^{\circ}\text{C}$
Junction temperature range	T_j	125	$^{\circ}\text{C}$
Ambient temperature range	T_{amb}	$-10 \text{ to } +100$	$^{\circ}\text{C}$

Thermal Resistance

Parameters	Symbol	Value	Unit
Junction ambient DIP16 SO16 on p.c. SO16 on ceramic	R_{thJA}	120 180 100	K/W

Electrical Characteristics

$V_S = -13\text{ V}$, $T_{\text{amb}} = 25^\circ\text{C}$, reference point Pin 10, unless otherwise specified

Parameters	Test Conditions / Pins	Symbol	Min.	Typ.	Max.	Unit
Supply Pin 11						
Supply voltage limitation	$-I_S = 3.5\text{ mA}$ $-I_S = 30\text{ mA}$	$-V_S$	14.5 14.6		16.5 16.8	V
Current requirement	$-V_S = 13.0\text{ V}$ (Pins 1, 2, 8 and 15 open)	$-I_S$			3.2	mA
Reference voltage source Pin 8						
Reference voltage	$I_L = 10\text{ }\mu\text{A}$ $I_L = 2.5\text{ mA}$	$-V_{\text{Ref}}$	8.6 8.4	8.9 8.8	9.2 9.1	V
Temperature coefficient	$I_S = 2.5\text{ mA}$ $I_S = 10\text{ }\mu\text{A}$	$\text{TC}_{V_{\text{Ref}}}$		-0.004 +0.006		%/K
Voltage monitoring Pin 11						
Turn-on threshold		$-V_{\text{Son}}$		11.3	12.3	V
Phase control – synchronization Pin 15						
Input current	Voltage sync.	$\pm I_{\text{syncV}}$	0.15		2	mA
Voltage limitation	$\pm I_L = 2\text{ mA}$	$\pm V_{\text{syncV}}$	8.0	8.5	9.0	V
Input current	Current sync. Pin 16	$\pm I_{\text{syncI}}$	3		30	μA
Reference ramp, figure 4						
Charging current	Pin 14	$-I_\phi$	1		100	μA
Start voltage	Pin 3	$-V_{\text{max}}$	1.85	1.95	2.05	V
Temperature coefficient of start voltage	Pin 3	TC_R		-0.003		%/K
Final voltage	Pin 3	$-V_{\text{min}}$	(V ₈ ± 200 mV)			
R _φ – reference voltage	$I_\phi = 10\text{ }\mu\text{A}$ Pins 14 and 11	$V_{R\phi}$	0.96	1.02	1.10	V
Temperature coefficient	$I_\phi = 10\text{ }\mu\text{A}$ Pin 14 $I_\phi = 1\text{ }\mu\text{A}$	$\text{TC}_{V_{R\phi}}$		0.03 0.06		%/K
Pulse output current	$V_{16} = -1.2\text{ V}$, figure 5, Pin 16	I_0	100	125	150	mA
Output pulse width	$V_S = V_{\text{limit}}$, $C_3 = 3.3\text{ nF}$, figure 6, Pin 16	t_p		30		μs
Automatic retriggering						
Repetition rate	$I_{15} \geq 150\text{ }\mu\text{A}$	t_{pp}	3	5	7.5	t_p
Threshold voltage	Pin 16	$\pm V_I$	20		60	mV
Soft start, figure 7 and 8 Pin 7						
Starting current	$V_7 = V_8$	$-I_0$	5	10	15	μA
Final current	$V_{7-10} = -1\text{ V}$	$-I_0$	15	25	40	μA
Discharge current		$+I_0$	0.5			mA
Output current	Pin 4	$+I_0$	0.2		2	mA
Supply voltage compensation, figure 9 Pin 15						
Transfer gain	I_{15}/I_5 Pin 15/5 (Pins 1 and 2 open)	G_i	14	17	20	
Output offset current	$V_{(R6)} = V_{15} = V_5 = 0$	$\pm I_0$			2	μA
Load current detection, $R_1 = R_2 = 3\text{ k}\Omega$, $V_{15} = 0$, $V_5 = V_6 = V_8$, figure 10						
Transfer gain	$I_5/150\text{ mV}$, $I_6/150\text{ mV}$	G_I	0.28	0.32	0.37	$\mu\text{A/mV}$
Output offset currents	Pin 5, Pin 6 - 8	$-I_0$	0	3	6	μA
Reference voltage	$I_1, I_2 = 100\text{ }\mu\text{A}$ Pins 1 and 2	$-V_{\text{Ref}}$	300		400	mV
Shunt voltage amplitude	see figure 2	$\pm V_{(R6)}$			250	mV

Parameters	Test Conditions / Pins	Symbol	Min.	Typ.	Max.	Unit
Load current limitation, Pin 6-8, figs. 11 to 14						
High load switching	Threshold V_{T70}	V_{T70}	4	4.35	4.7	V
Overload switching	Threshold V_{T100}	V_{T100}	5.8	6.2	6.6	V
Restart switching	Threshold V_{T25}	V_{T25}	1.25	1.55	1.85	V
Input current	Enquiry mode	I_i			1	μA
Output impedance	Switching mode	R_0	2	4	8	$\text{k}\Omega$
Programming input, figure 2, Pin 9						
Input voltage - auto-start	Pin 9 open	$-V_9$	3.8	4.3	4.7	V
Input current	$V_9 = 0$ (α_{max})	$-I_9$	5	10	20	μA
	$V_9 = V_8$ (I_{max})	I_9	5	10	20	μA
High load output, V_{T70}, figure 12, $I_{12} = -3$ mA, Pin 11-12						
Saturation voltages	$V_{6-8} \leq V_{T70}$	V_{sat}	0.5	0.75	1.0	V
	$V_{6-8} \geq V_{T70}$	V_{lim}	7.0	7.4	7.8	V
Overload output, V_{T100}, $V_9 = \text{open}$ or $V_9 = V_{10}$, fig. 13						
Leakage current	$V_{6-8} \leq V_{T25}$ $V_{13} = (V_{11}+1)\text{V}$ Pin 13	I_{lk}			0.5	μA
Saturation voltages	$V_{6-8} \geq V_{T100}$, $I_{13} = 10 \mu\text{A}$ Pins 11-13	V_{sat}			0.1	V
Output current, max. load	$V_9 = V_8$, fig. 13 Pin 13	I_{13}			1	mA
Leakage current	$V_6 \leq V_{T100}$ Pin 13	I_{lk}			4	μA
Output impedance	Open collector $V_6 \geq V_{T100}$ Pin 13	R_0	2	4	8	$\text{k}\Omega$
Saturation voltage	$V_{6-8} \geq V_{T100}$, $I_{13} = 10 \mu\text{A}$ Pin 13	V_{13-8}		100		mV

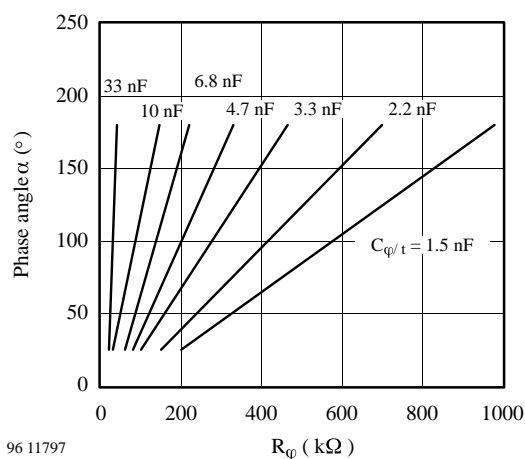

Figure 4.

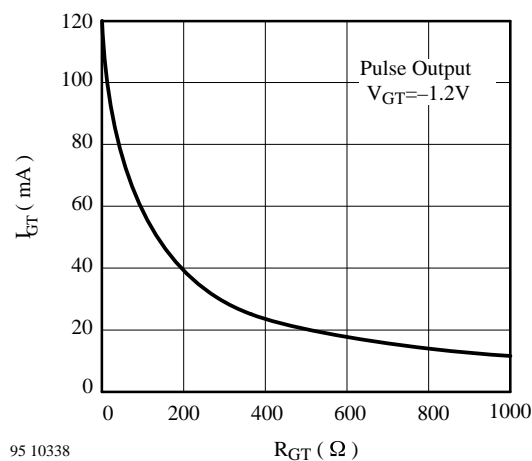

Figure 5.

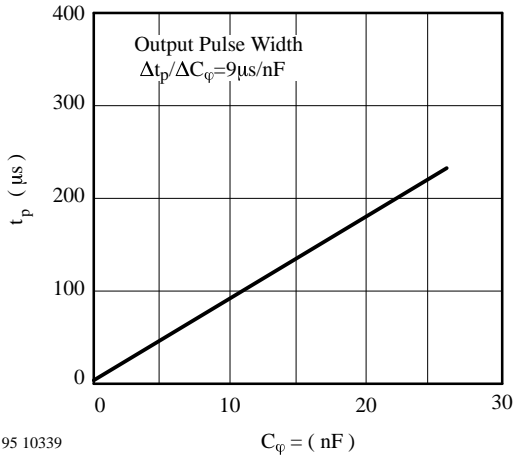

Figure 6.

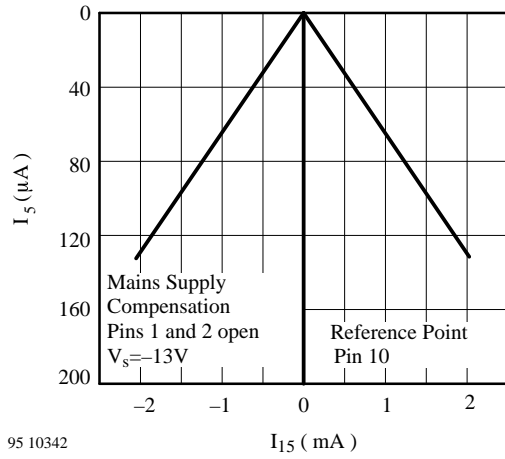

Figure 9.

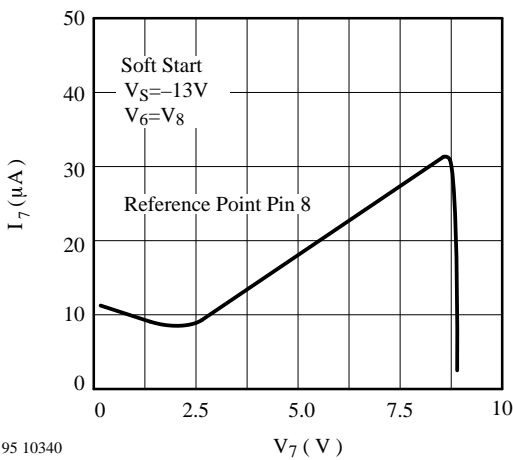

Figure 7.

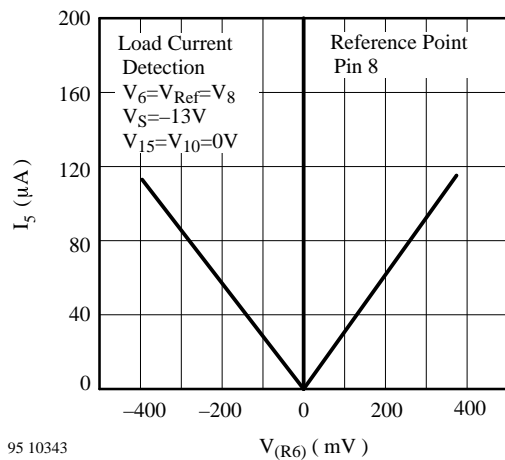

Figure 10.

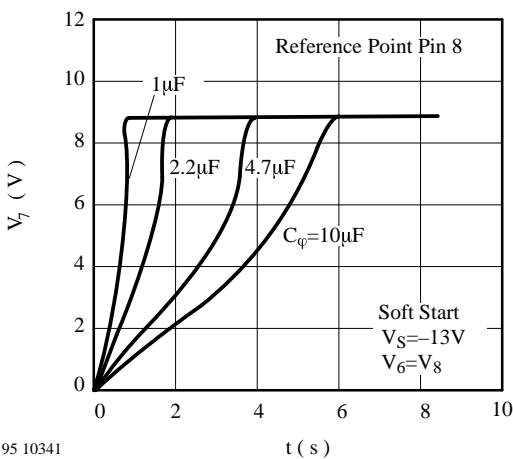

Figure 8.

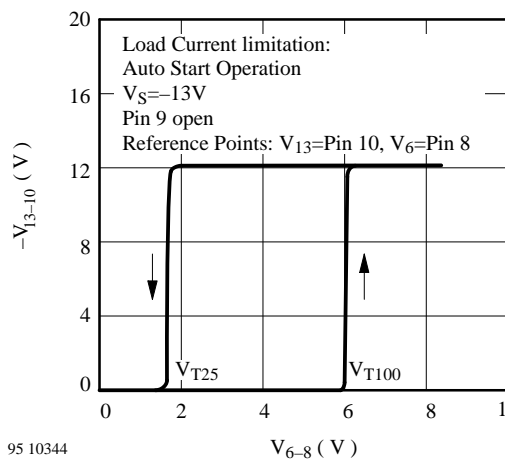

Figure 11.

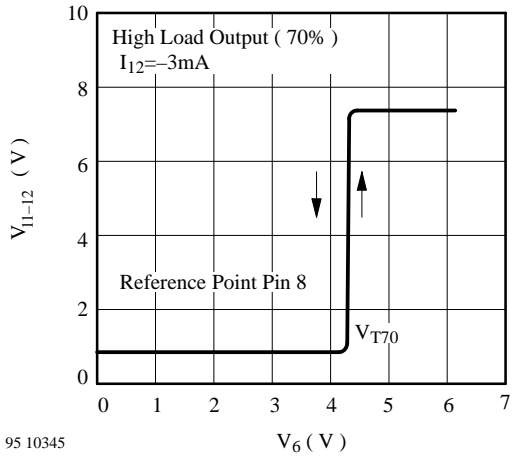

Figure 12.

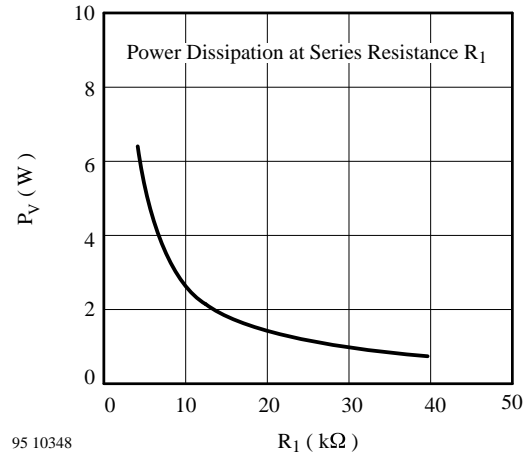

Figure 15.

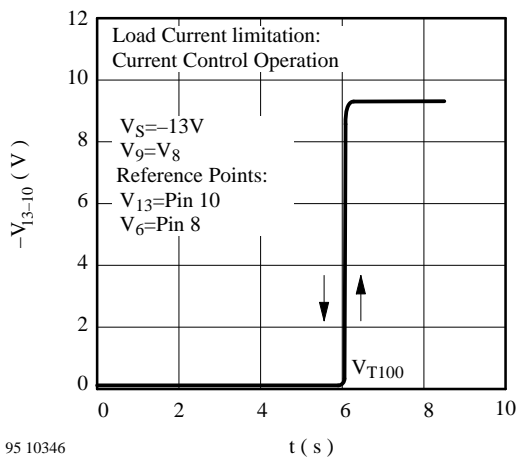

Figure 13.

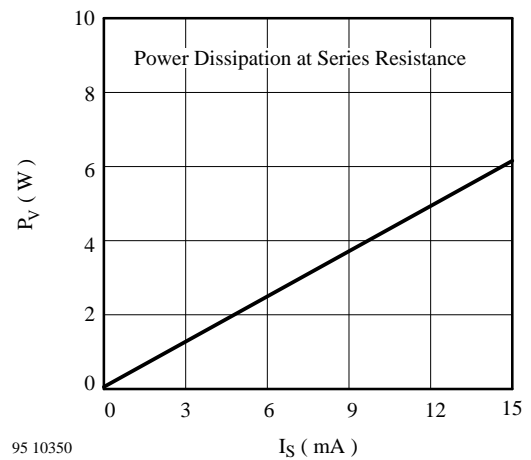

Figure 16.

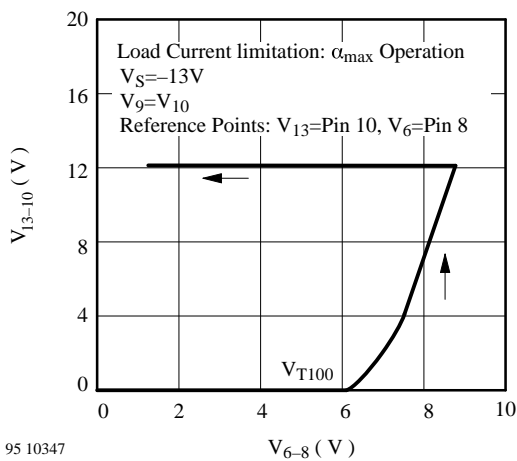

Figure 14.

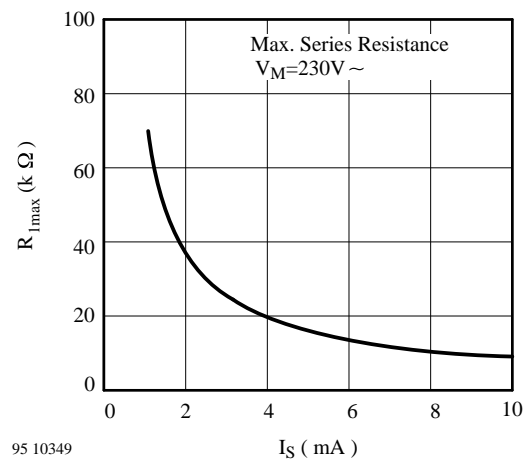

Figure 17.

Application Circuit

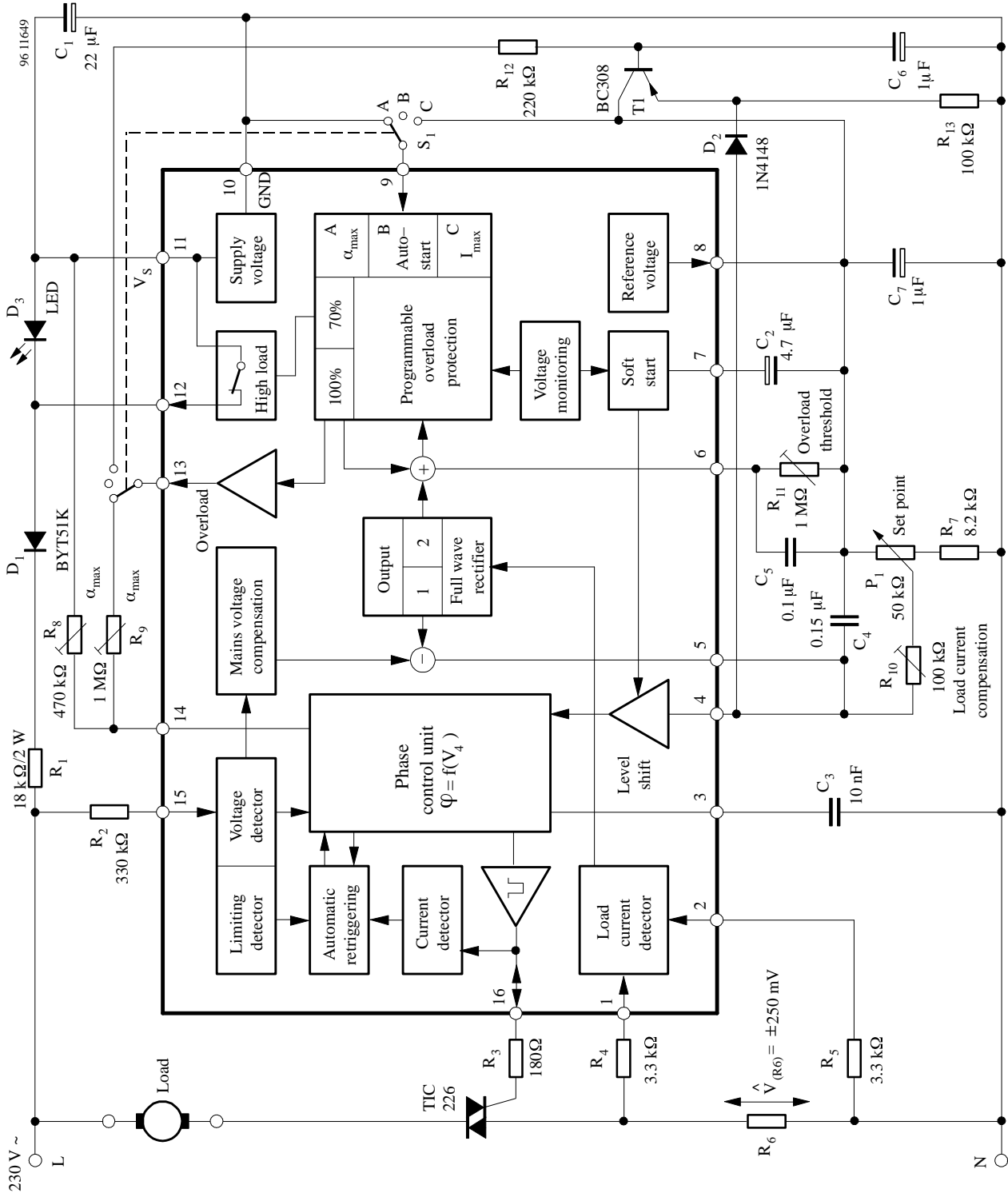
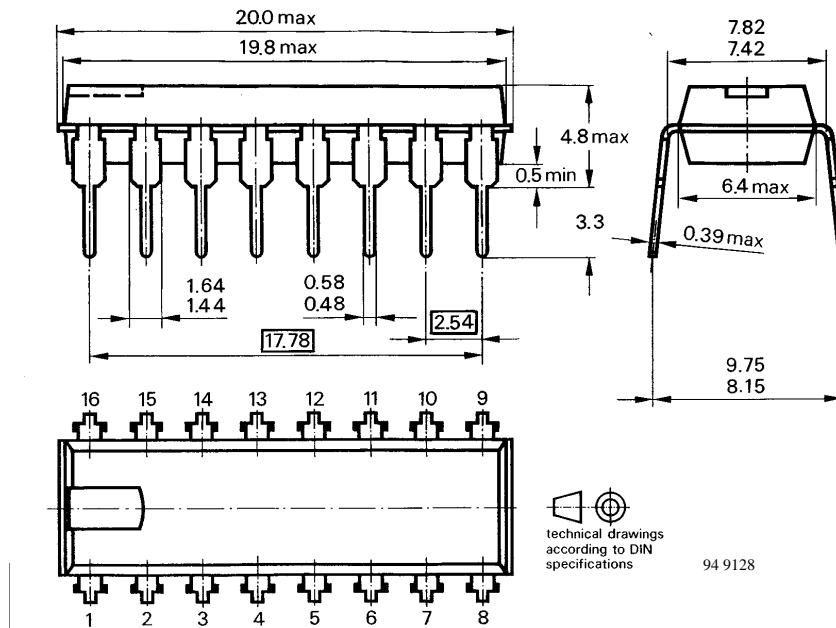

Figure 18.

Dimensions in mm

Package: DIP16



Package: SO16

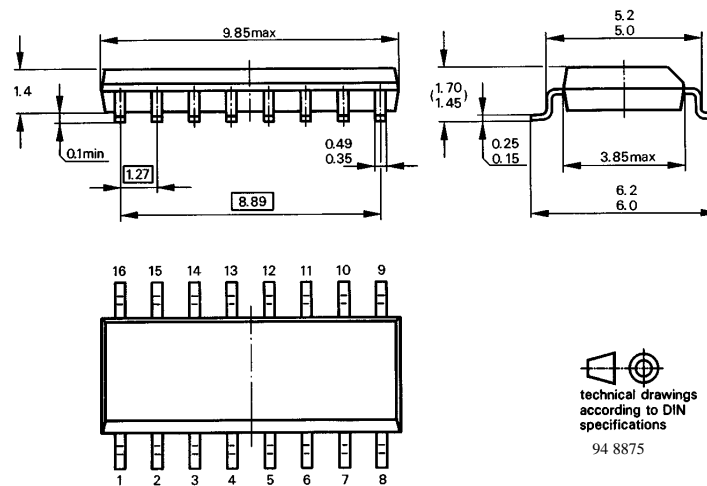

Ozone Depleting Substances Policy Statement

It is the policy of **TEMIC TELEFUNKEN microelectronic GmbH** to

1. Meet all present and future national and international statutory requirements.
2. Regularly and continuously improve the performance of our products, processes, distribution and operating systems with respect to their impact on the health and safety of our employees and the public, as well as their impact on the environment.

It is particular concern to control or eliminate releases of those substances into the atmosphere which are known as ozone depleting substances (ODSs).

The Montreal Protocol (1987) and its London Amendments (1990) intend to severely restrict the use of ODSs and forbid their use within the next ten years. Various national and international initiatives are pressing for an earlier ban on these substances.

TEMIC TELEFUNKEN microelectronic GmbH semiconductor division has been able to use its policy of continuous improvements to eliminate the use of ODSs listed in the following documents.

1. Annex A, B and list of transitional substances of the Montreal Protocol and the London Amendments respectively
2. Class I and II ozone depleting substances in the Clean Air Act Amendments of 1990 by the Environmental Protection Agency (EPA) in the USA
3. Council Decision 88/540/EEC and 91/690/EEC Annex A, B and C (transitional substances) respectively.

TEMIC can certify that our semiconductors are not manufactured with ozone depleting substances and do not contain such substances.

We reserve the right to make changes to improve technical design and may do so without further notice.

Parameters can vary in different applications. All operating parameters must be validated for each customer application by the customer. Should the buyer use TEMIC products for any unintended or unauthorized application, the buyer shall indemnify TEMIC against all claims, costs, damages, and expenses, arising out of, directly or indirectly, any claim of personal damage, injury or death associated with such unintended or unauthorized use.

TEMIC TELEFUNKEN microelectronic GmbH, P.O.B. 3535, D-74025 Heilbronn, Germany
Telephone: 49 (0)7131 67 2831, Fax number: 49 (0)7131 67 2423