

Ultrasonic Suspension Module DIY Kit

1.Introduction:

It is a ultrasonic suspension module. This is a mini ultrasonic levitation device that can levitate foam balls. The device consists of a single-chip microcomputer, a driver chip and two ultrasonic probes. Mainly used for students or DIY electronics enthusiasts to learn.

2.Feature:

- 1>.It comes with a DC power interface for easy charging.
- 2>.It has a program download interface and is easy to use.
- 3>.It supports long-term suspension,the motherboard will be slightly hot.
- 4>.It has a power indicator and an ultrasonic suspension indicator,and you can see the working status of the product by observing the indicator.

3.Parameter:

- 1>.Input Voltage:DC 12V
- 2>.Input Current:70mA(Max)
- 3>.LED Red:Power Indicator
- 4>.LED Green:Ultrasonic levitation indicator
- 5>.Probe Spacing:22mm
- 6>.Work Temperature:-25℃~85℃
- 7>.Work Humidity:5%~95%RH
- 8>.Size(Installed>:62*42*42mm

4.Working Principle:

1>.Ultrasonic standing wave suspension is through the existence of a certain distance between the ultrasonic transmitting end and the reflecting end (or another transmitting end) (called the resonant cavity distance).

2>.The transmitted wave and the reflected wave (or another sound wave) are continuously superimposed to eventually form a standing wave. The sound wave force on the object at the node of the standing wave overcomes the effect of gravity and finally achieves the effect of suspension.

5.Component Listing:

| NO. | Component Name | PCB Marker | Parameter | QTY |
|-----|-------------------------------|-------------|---------------|-----|
| 1 | 0805 SMD Capacitor | C1,C2,C4,C5 | 0.1uF | 4 |
| 2 | Electrolytic capacitor | C3 | 25V 10uF | 1 |
| 3 | DC Power Socket | CON1 | DC-005 | 1 |
| 4 | SMD LED | LED1,LED2 | Red and Green | 2 |
| 5 | Curved Row Needle | P1 | 4P | 1 |
| 6 | 0805 SMD Resistor | R1,R3,R4 | 5.1Kohm | 3 |
| 7 | 0805 SMD Resistor | R2 | 10Kohm | 1 |
| 8 | SMD Single Chip Microcomputer | U1 | STC15F104W | 1 |
| 9 | SMD IC | U2 | TPS70933 | 1 |
| 10 | SMD IC | U3 | TC4427 | 1 |
| 11 | Ultrasonic Probe | T | | 2 |
| 12 | Single Pass Copper Column | | M2*12+3 | 4 |
| 13 | Single Pass Copper Column | | M2*17+3 | 4 |
| 14 | Double Pass Copper Column | | M2*5 | 4 |

| | | | | |
|----|-----------------|--|-------------|---|
| 15 | Screw | | M2*6 | 4 |
| 16 | Round PCB board | | 40*40*1.6mm | 3 |

Note:Users can complete the installation according to the PCB silk screen and component list.

6.Schematic Diagram:

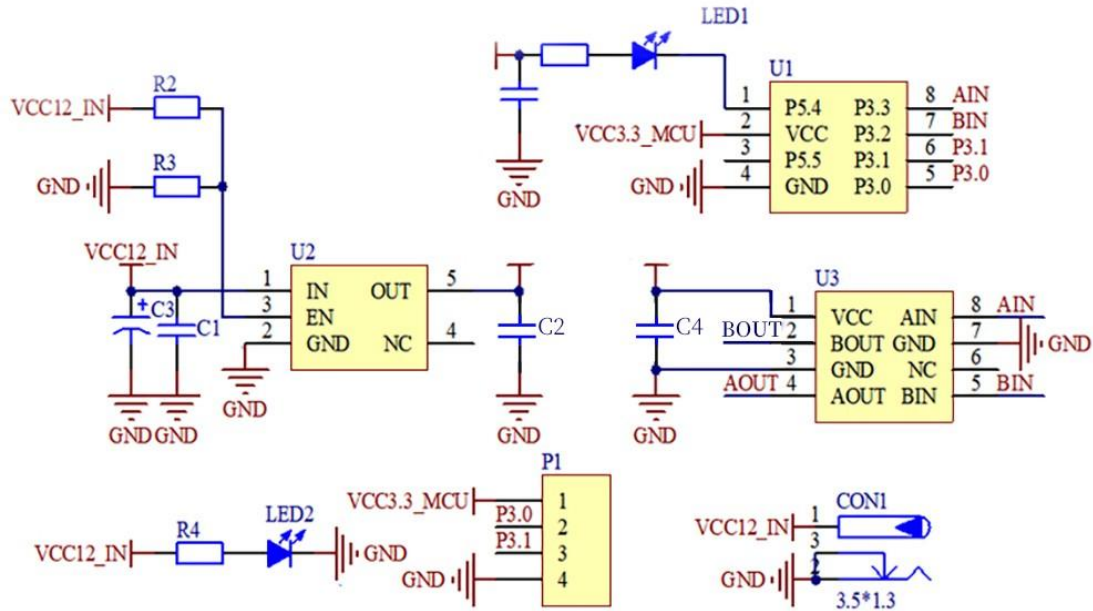

7.Application:

- 1>.Training welding skills
- 2>.Student school
- 3>.DIY production
- 4>.Project Design
- 5>.Electronic competition

8.Note:

- 1>.It has some SMD components, you can put it on the PCB and fix it with tin.
 - 2>.Use tweezers to gently clamp the foam ball and gently release it.
 - 3>.You can also use metal mesh to place the foam ball in the middle of the probe.
 - 4>.Operation video:<http://attach01.oss-us-west-1.aliyuncs.com/IC/Video/GY20451.mp4>
 - 5>.P1 interface no need install components. It is used to update code on STC15F104W.
- It is not recommended to update the code and designers also do not share or provide code.

9.Installation Tips:

- 1>.User needs to prepare the welding tool at first.
 - 1.1>.Soldering iron (<50 Watt)
 - 1.2>.Rosin core ("radio") solder
 - 1.3>.Wire cutters
 - 1.4>.Wire strippers
 - 1.5>.Philips screwdriver
- 2>.Please be patient until the installation is complete.
- 3>.The package is DIY kit.It need finish install by user.
- 4>.The soldering iron can't touch the components for a long time(1.0 second>), otherwise

it will damage the components.

5>.Pay attention to the positive and negative of the components.

6>.Strictly prohibit short circuit.

7>.User must install the LED according to the specified rules.Otherwise some LED will not light.

8>.Install complex components preferentially.

9>.Make sure all components are in right direction and right place.

10>.It is strongly recommended to read the installation manual before starting installation!!!

11>.Please wear anti-static gloves or anti-static wristbands when installing electronic components.

10.Installation Steps(Please be patient install!!!):

1>.Step 1:Install 1pcs SMD IC STC15F104W on U1. Verify and confirm the installation direction of IC. The small dots on the PCB coincide with those on the IC to locate the installation direction.

2>.Step 2:Randomly select a position on the soldering pins of IC on the PCB, and melt a little solder on it.

3>. Step 3:Fix the STC15F104W: Use a soldering iron to melt the tin on the pad just now, hold the IC with tweezers with the other hand and place and press U1 to prevent it from moving. Take care to match and align each pad. Then remove the soldering iron. Remove the tweezers after the solder has cooled and solidified.

4>.Step 4:Use tin and soldering iron to connect other pins on IC to pads on PCB.

5>.Step 5:Install 1pcs SMD IC TPS70933 at U2 by the same methods.

6>.Step 6:Install 1pcs SMD IC TC4427 at U3 by the same methods.

7>.Step 7:Install 1pcs 10Kohm chip resistor at R2,choose one end to melt the solder, use a soldering iron to melt the tin on the pad just now, and place and press the chip resistor with tweezers in the other hand to prevent movement . After aligning the pads, remove the soldering iron. Remove the tweezers after the solder has cooled and solidified.

8>.Step 8:Install 3pcs 5.1Kohm chip resistors at R1, R3, R4.

9>.Step 9:Install 4pcs 0.1uF chip capacitors at C1, C2, C4, C5.

10>.Step 10:Install 2pcs SMD LEDs at LED1 and LED2. Note that the positive and negative poles of the LED correspond to the positive and negative poles on the board. The green on the LED corresponds to the two white lines on the board LED1 and LED2. Do not connect them in reverse.

11>.Step 11:Install a 1pcs 25V 10uF electrolytic capacitor at C3, pay attention to the white part of the electrolytic capacitor aligning with the white dotted line of C3, and then solder it.

12>.Step 12:Install 1pcs DC-005 Power Socket at CON1.

13>.Step 13: Install the 2pcs ultrasonic sensor at T, note that the small black circle pin of the sensor corresponds to T+.

14>.Step 14:Select the P1 board, install 2pcs screws and 2pcs M2*5 copper posts, pay attention to the installation direction.

15>.Step 15:Then install 2pcs M2*5 copper pillars and 2pcs M2*12+3 copper pillars, paying attention to the installation direction.

16>.Step 16:Connect the P2 board and the P1 board through 2 M2*12+3 copper posts.

17>.Step 17:Connect 4 M2*17+3 copper pillars to M2*12+3 copper pillars respectively.

18>.Step 18:Finally, connect with the P3 board through 2 screws.

11.Install shown steps:

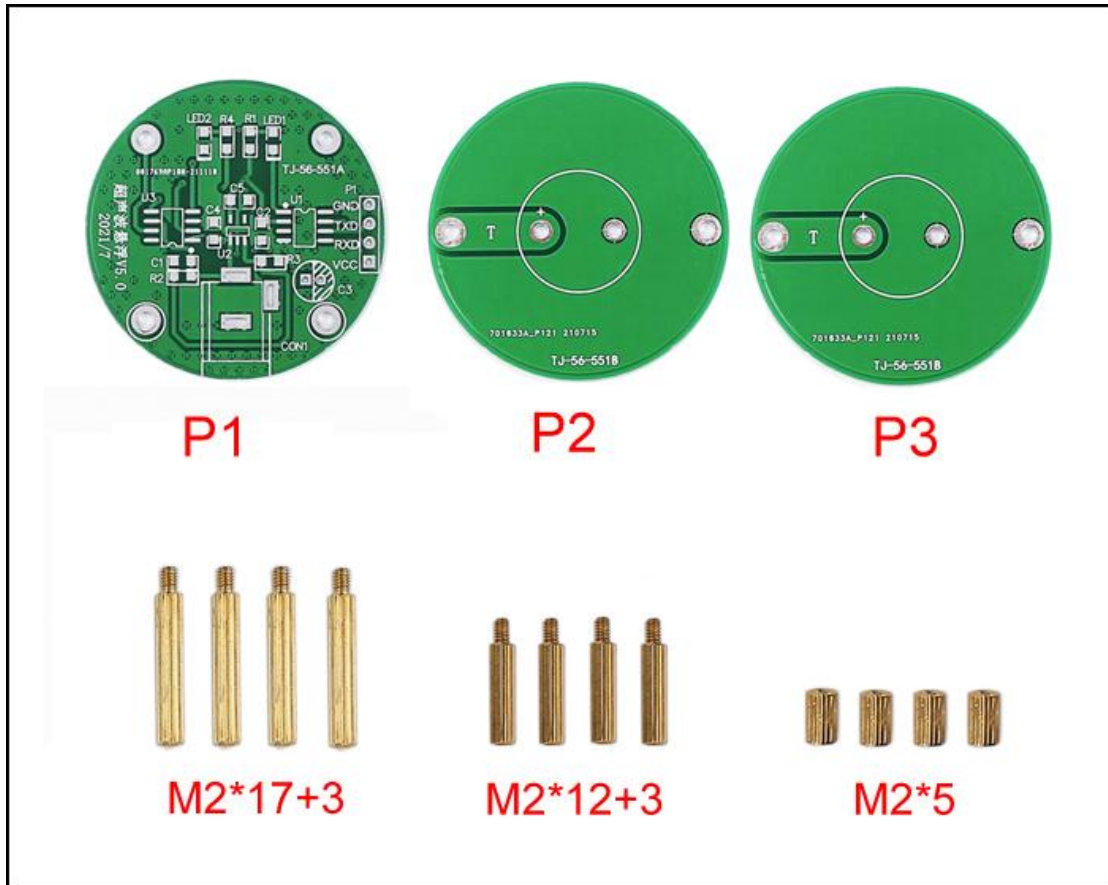

Step 1: Install 1pcs SMD IC STC15F104W on U1. Verify and confirm the installation direction of IC. The small dots on the PCB coincide with those on the IC to locate the installation direction.

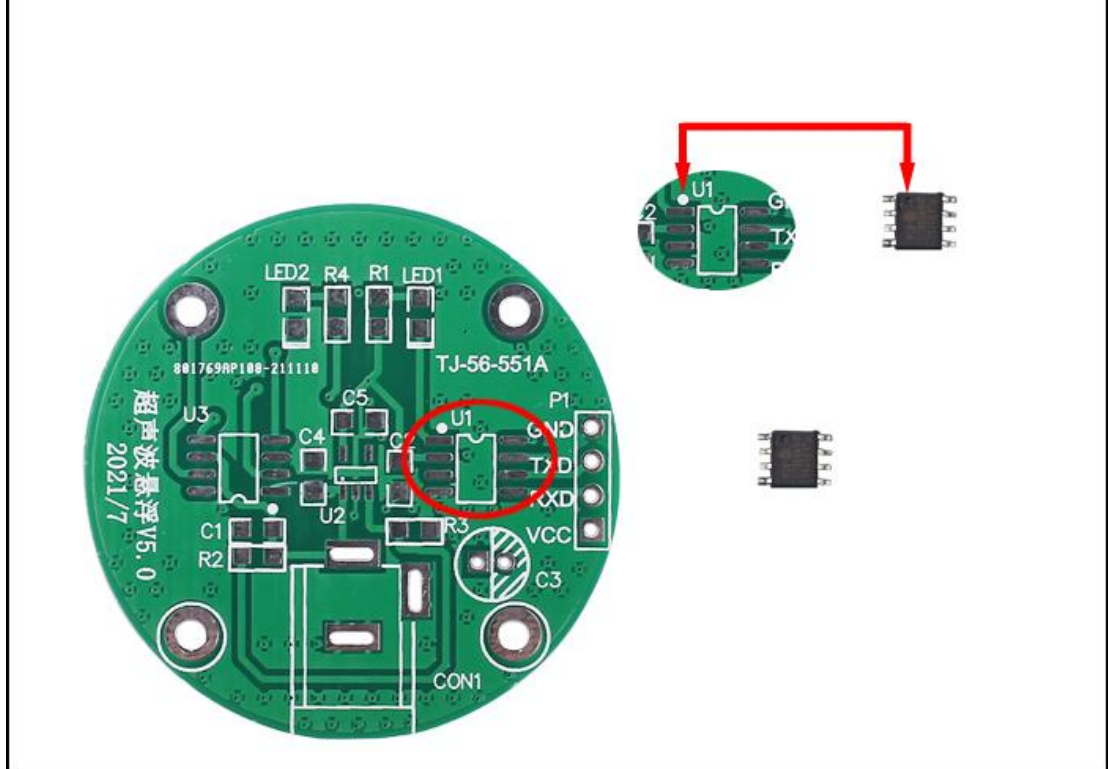

Step 2. Randomly select a position on the soldering pins of IC on the PCB, and melt a little solder on it.

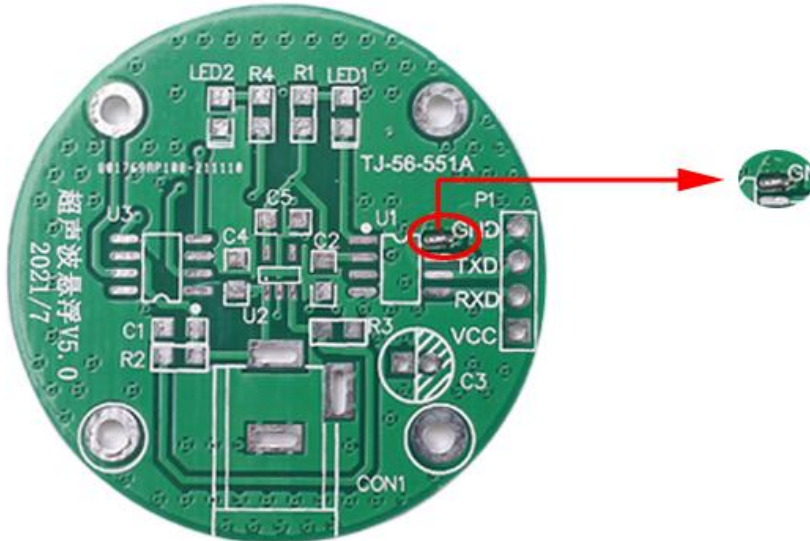

Step 3: Fix the STC15F104W: Use a soldering iron to melt the tin on the pad just now, hold the STC15F104W with tweezers with the other hand and place and press U1 to prevent it from moving. Take care to match and align each pad. Then remove the soldering iron. Remove the tweezers after the solder has cooled and solidified.



Step 4. Use tin and soldering iron to connect other pins on IC to pads on PCB.

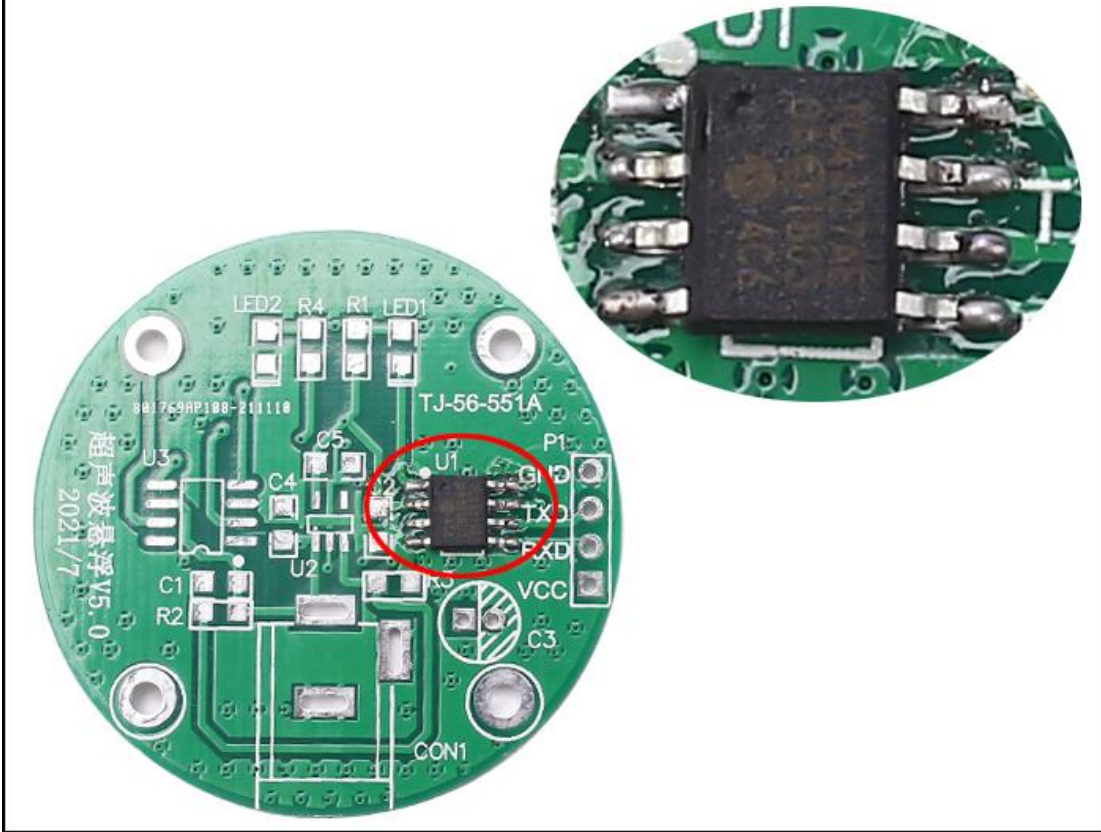

Step 5: Install 1pcs SMD IC TPS70933 at U2 by the same methods.

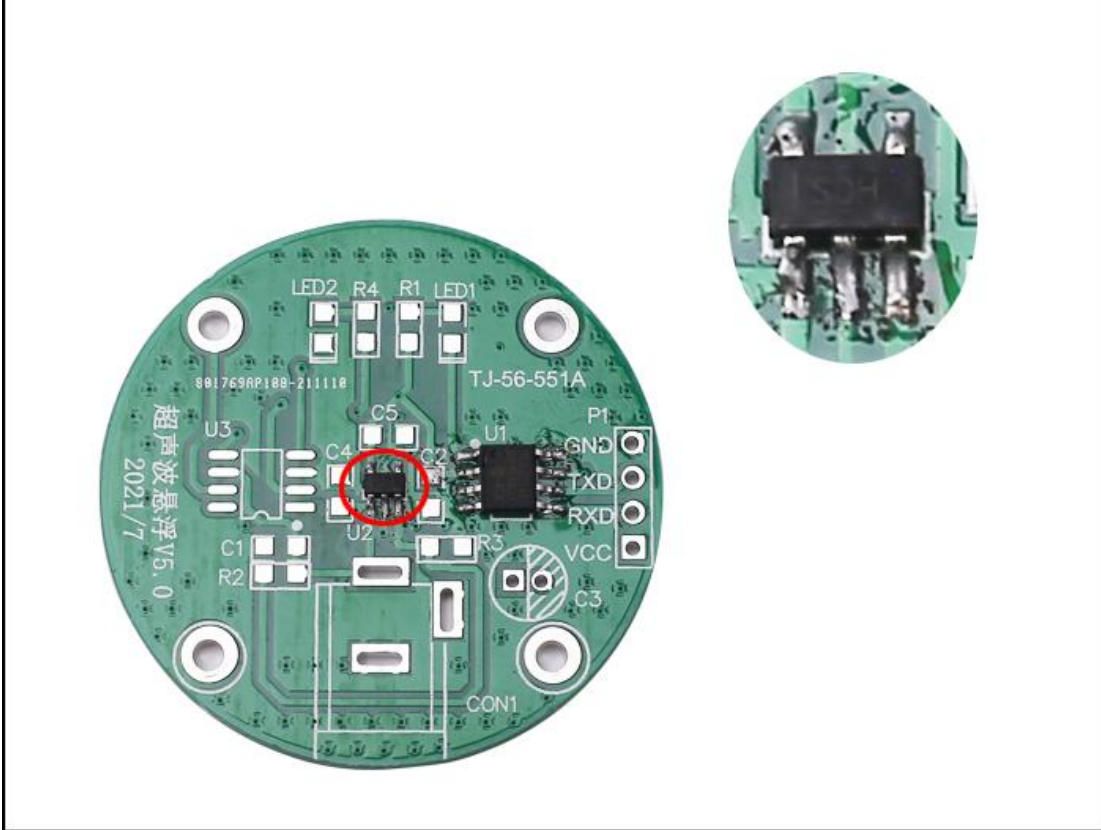

Step 6: Install 1pcs SMD IC TC4427 at U3 by the same methods.

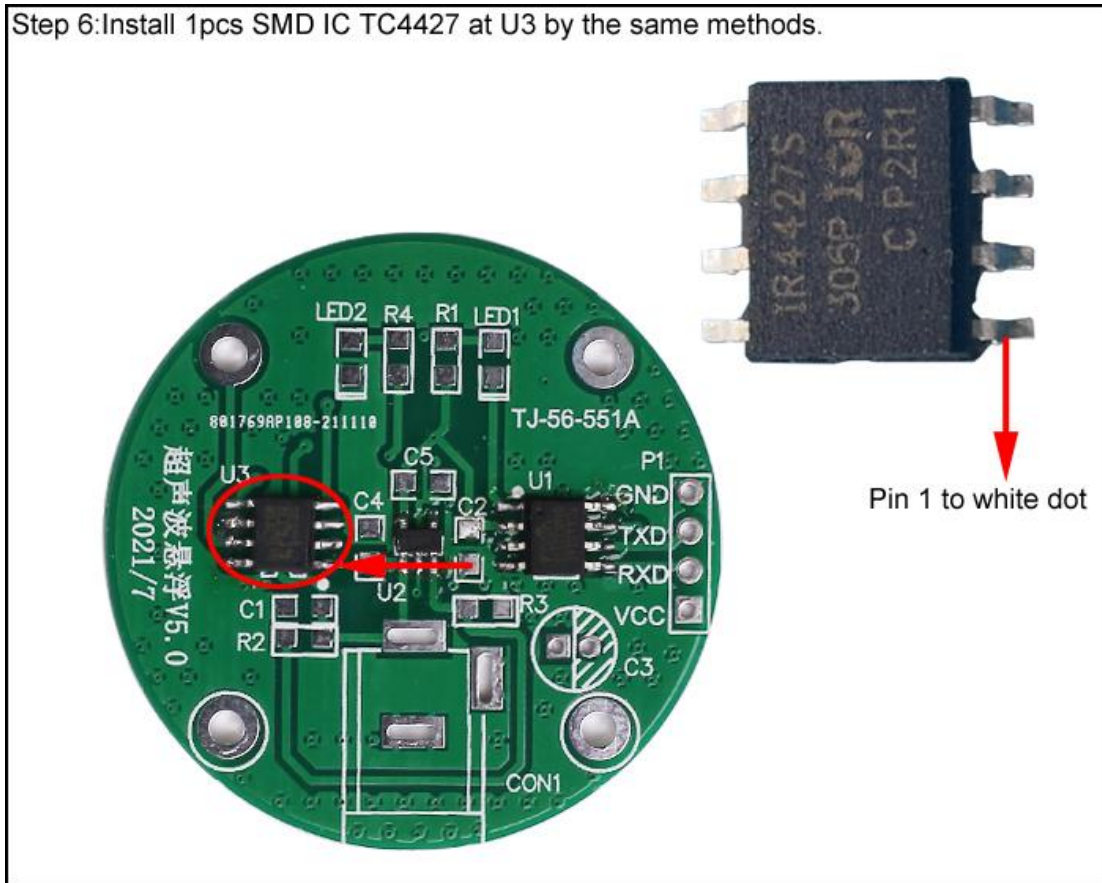

Step 7. Install 1pcs 10Kohm chip resistor at R2, choose one end to melt the solder, use a soldering iron to melt the tin on the pad just now, and place and press the chip resistor with tweezers in the other hand to prevent movement. After aligning the pads, remove the soldering iron. Remove the tweezers after the solder has cooled and solidified.

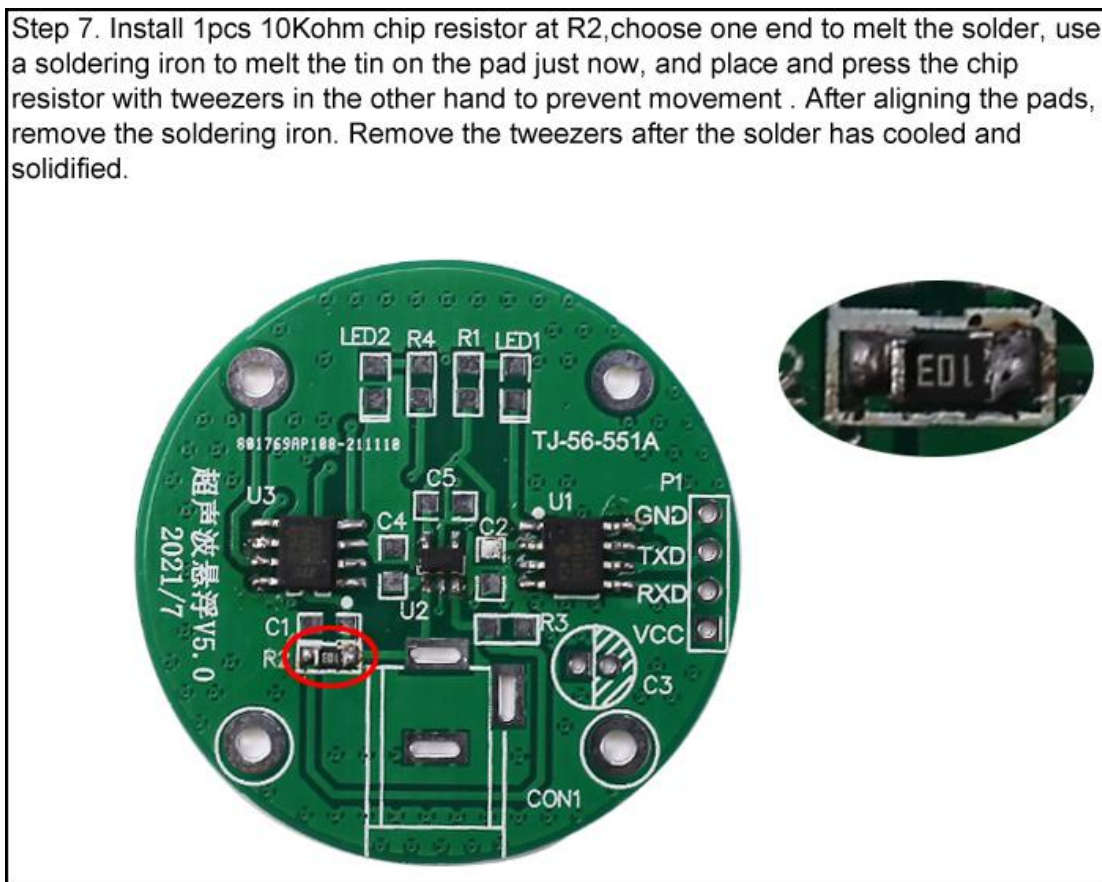

Step 8. Install 3pcs 5.1Kohm chip resistors at R1, R3, R4.

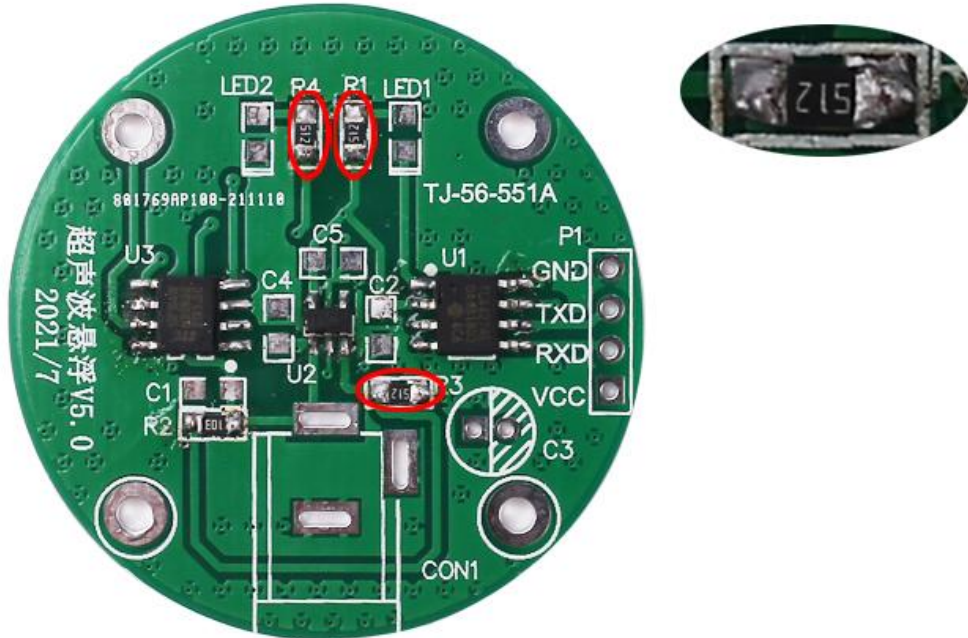

Step 9. Install 4pcs 0.1uF chip capacitors at C1, C2, C4, C5.

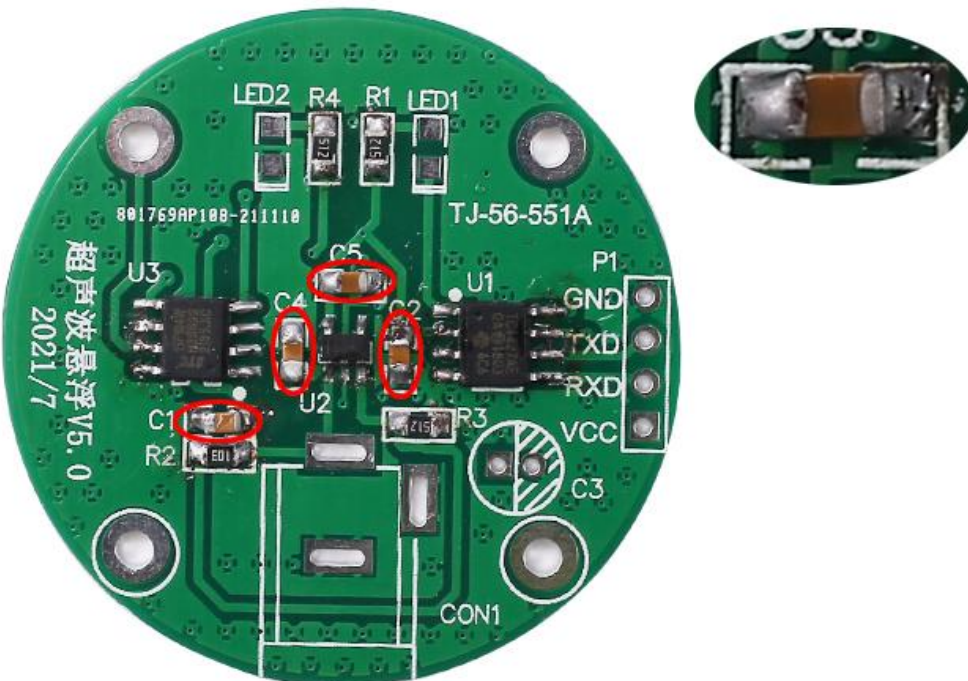

Step 10. Install 2pcs SMD LEDs at LED1 and LED2. Note that the positive and negative poles of the LED correspond to the positive and negative poles on the board. The green on the LED corresponds to the two white lines on the board LED1 and LED2. Do not connect them in reverse.

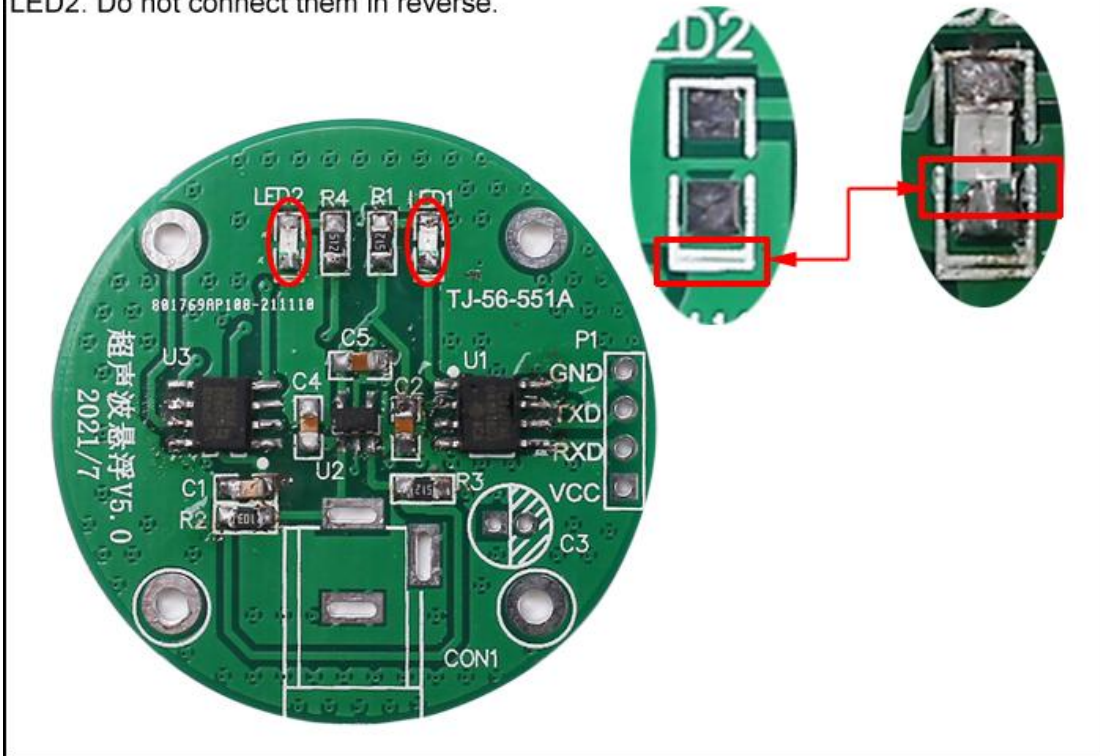

Step 11. Install a 1pcs 25V 10uF electrolytic capacitor at C3, pay attention to the white part of the electrolytic capacitor aligning with the white dotted line of C3, and then solder it.

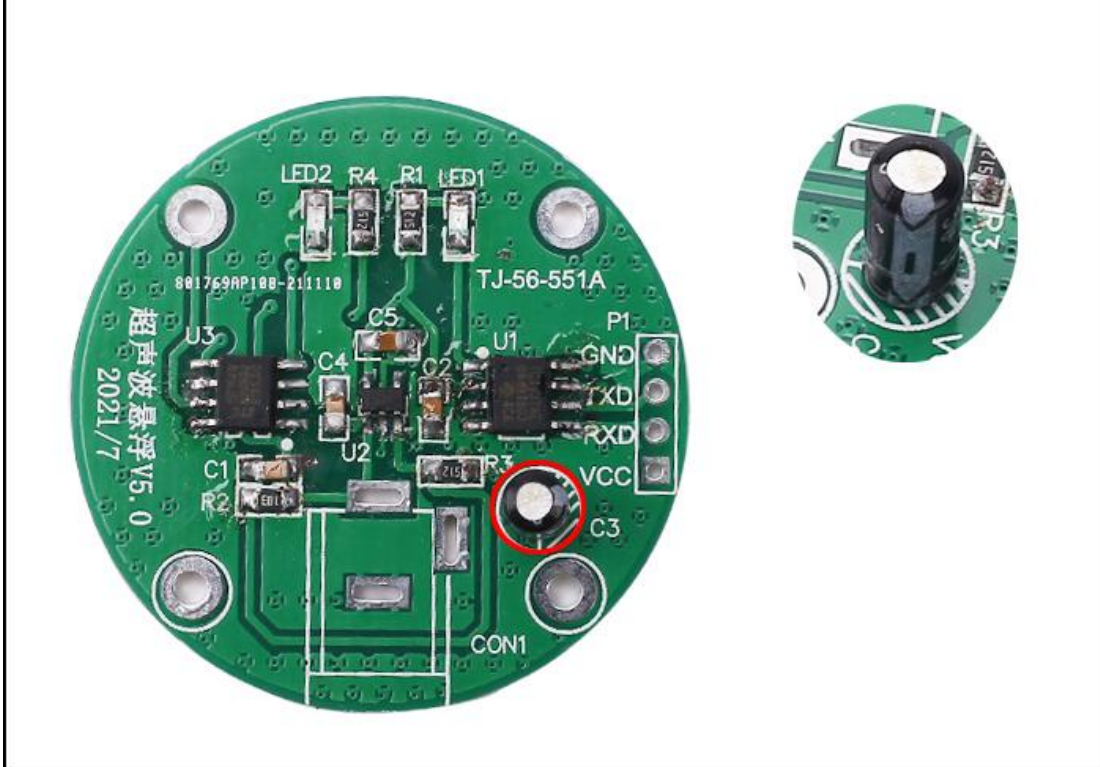

Step 12. Install 1pcs DC-005 Power Socket at CON1.

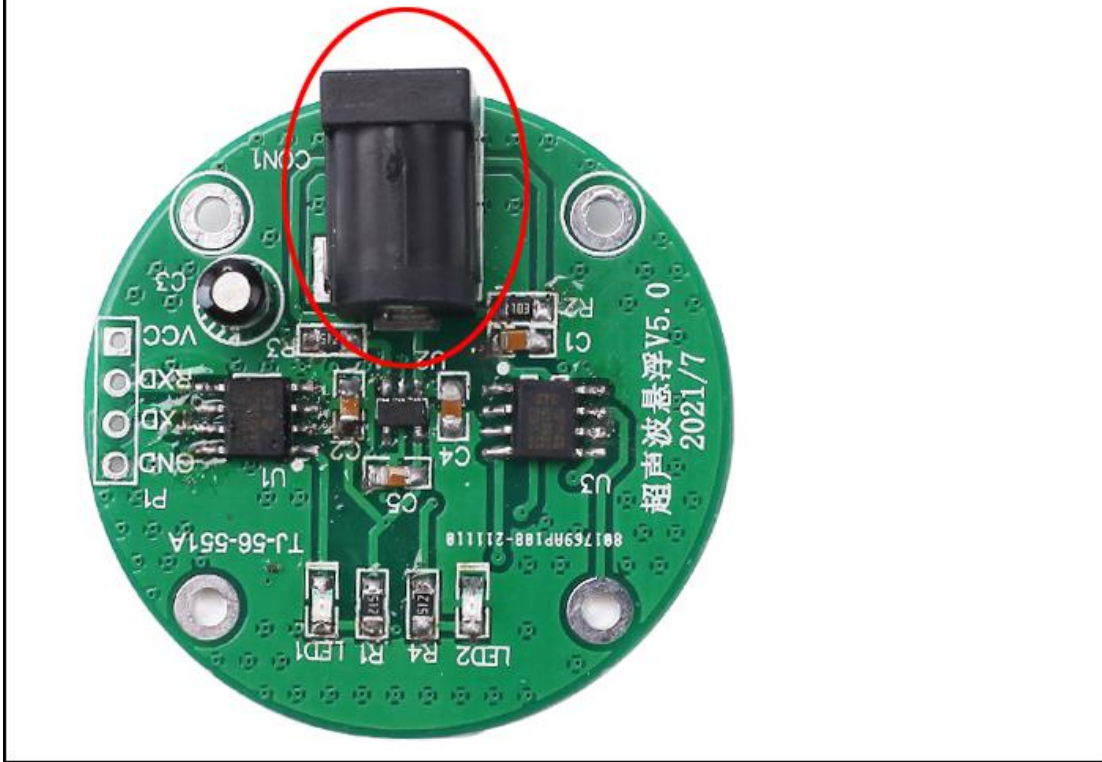

Step 13. Install the 2pcs ultrasonic sensor at T, note that the small black circle pin of the sensor corresponds to T+.



Step 14. Select the P1 board, install 2 screws and 2 M2*5 copper posts, pay attention to the installation direction.

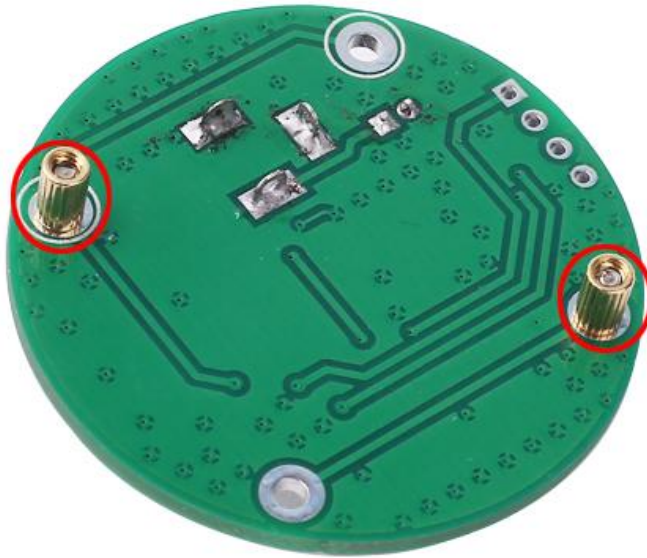

Step 15. Then install 2pcs M2*5 copper pillars and 2pcs M2*12+3 copper pillars, paying attention to the installation direction.

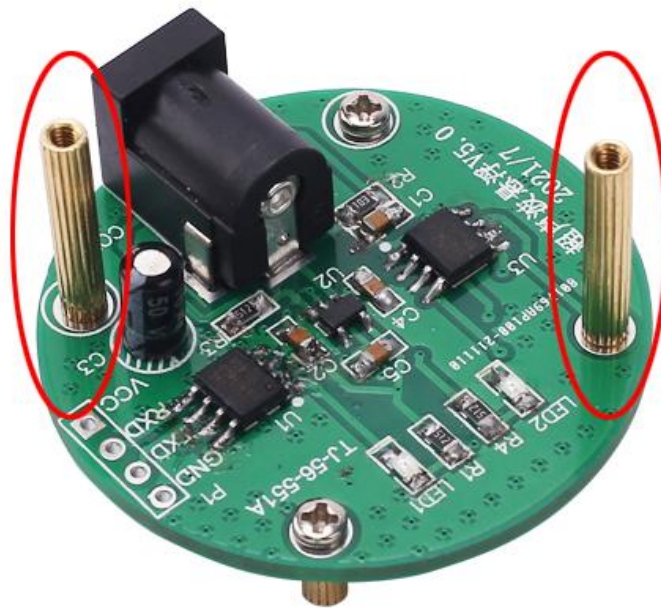

Step 16. Connect the P2 board and the P1 board through 2 M2*12+3 copper posts.



Step 17. Connect 4 M2*17+3 copper pillars to M2*12+3 copper pillars respectively.



Step 18. Finally, connect with the P3 board through 2 screws.

