

4.7nF 500V KEMET 1501204MRTCL02NT  
 33pF 1000V Wima FKP20100331D00HF00  
 68pF 1000V Wima FKP20100681D00H000

.param rsource=10k  
 .param csource=10p

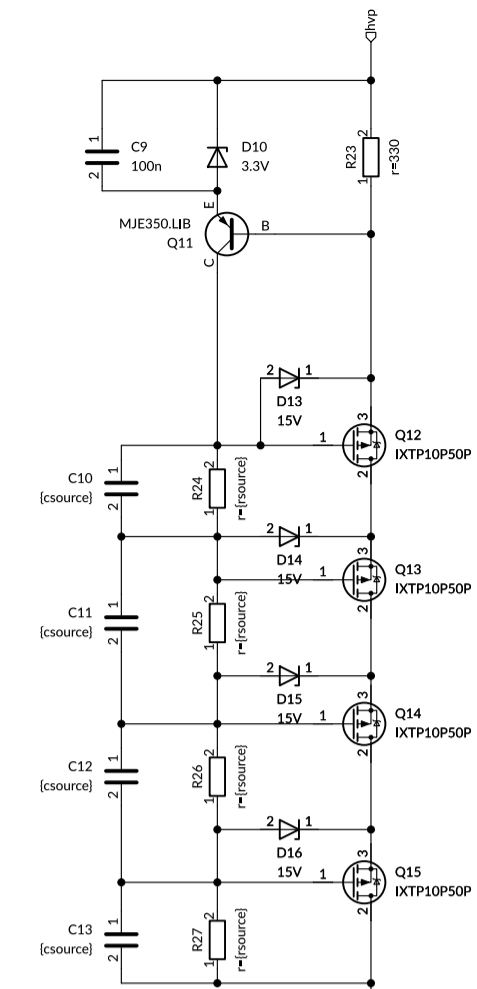

.param rmos=20k  
 .param cmos=33p

