

Nacharbeit Proxxon- Spindelführung M 1:1

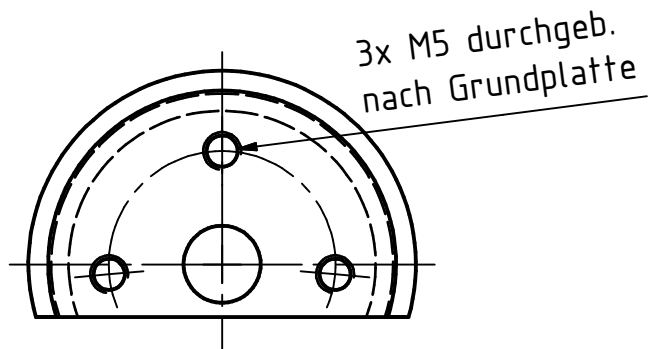

Verwendung der Zentrierhilfe zum Bohren der Spindelführung

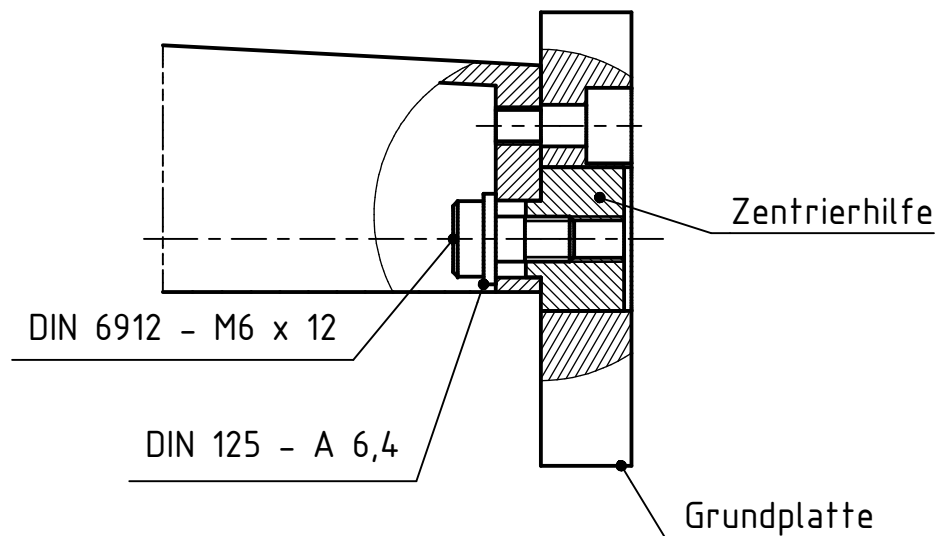

Zentrierhilfe Al M:1

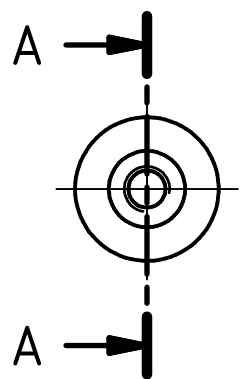

A-A (1 : 1)

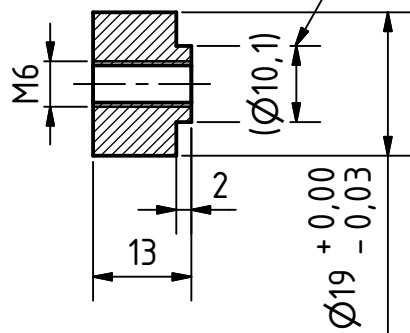

An Spindelführung angepasst

Datum	Name		
16.07.2024	JR		
M 1:1	Spindelführung		
		A4	