

CRYSTAL CLOCK OSCILLATORS

T-50-23

Our Crystal Clock Oscillator series are available over the high frequency range 4.01 MHz to 70 MHz. Their design can meet TTL compatible output. Those internal used crystal has been operated either fundamental or overtone oscillation mode. The characteristic high quality is achieved by integration of technologies, hybrid and crystal.

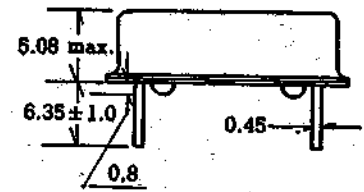
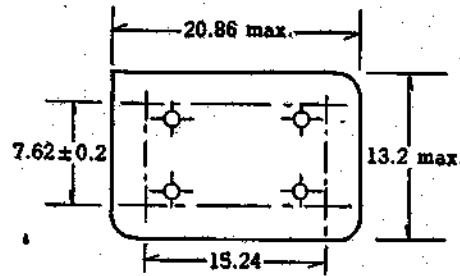

PIN CONNECTION

1	NC
7	GND.
8	OUT PUT
14	+5 DVC

WAVE SHAPE

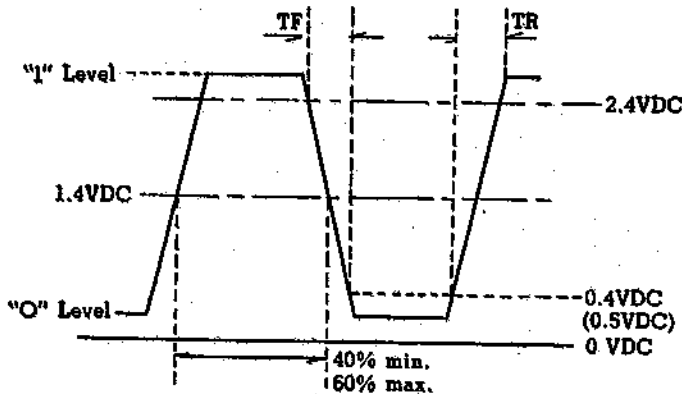

TEST CIRCUIT

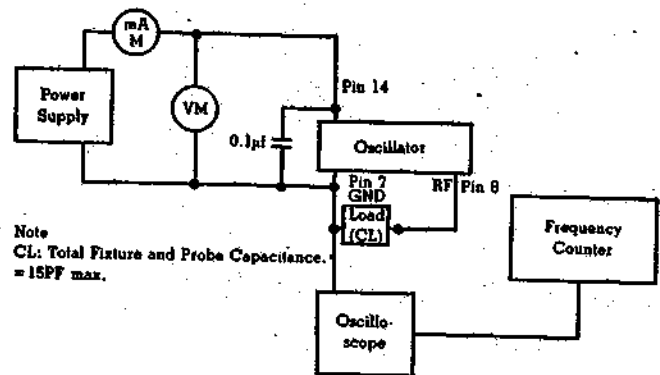

ITEM	TYPE	DOC-2S	DOC-20(E.N)	DOC-20S	DOC-70
Frequency Range		1.0 to 4.0 MHz	4.01 to 20 MHz		20.1 to 70 MHz
Freq. Tolerance		50ppm, 100ppm, 200ppm, SELECT reserve			
Operating Temp. Range		0°C to +70°C			
Storage Temp.		-55°C to +125°C			
OUT PUT	Level	TTL Level standard			
	"0" Level	+0.4V max.	+0.4V max.		+0.4Vmax./20.1-32.0 MHz +0.5Vmax./32.1-70.0 MHz
	"1" Level	+2.4V min.			
	Symmetry	60/40 to 40/60 at 1.4V DC Level			
	Rise and Fall Time 0.4-2.4 DC Level	15ns max.	15ns max./4.01-8.99 MHz 10ns max./9.0-20.0 MHz		10ns max./20.1-32 MHz 6ns max./32.1-70 MHz
	Output Load	1 to 10 TTL STD Gates	1 to 10 TTL STD Gates	1 to 5 TTL STD Gates	1-10 TTL STD Gates
Power Voltage		+5V DC ±0.5V			
Consumption Current		30mA max./+5V/25°C			

ORDERING INFORMATION

Please state clearly the following qualifications when you place an order.

CRYSTAL OSCILLATOR

1. Package Size:
2. Nominal Frequency: _____ MHz (KHz)
3. Frequency Tolerance: _____ × 10⁻⁶ at 25°C
4. Output/Waveform: "0" Level _____ "1" Level _____

2 OUT PUT CRYSTAL CLOCK OSCILLATOR

CHARACTERISTICS

- 2 output frequencies are available between 8,000MHz and 32,000 MHz upon request.
- Capable to match C-MOS or 10 LS TTL.
- High reliability by metal sealing.

DIMENSIONS AND OUT PUT TERMINAL

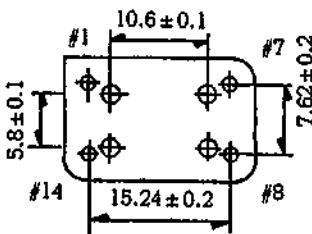
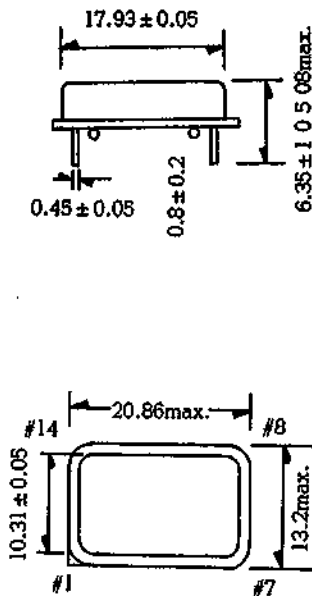

Fig-1

PIN CONNECTION

- #1 OUT-1 8.0~32.0MHz
- #7 GND (CASE GND)
- #8 OUT-2 8.0~32.0MHz
- #14 × 5V DC

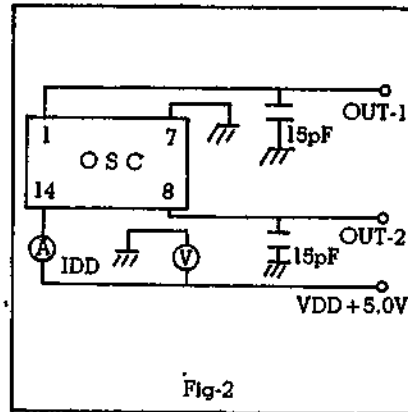

Fig-2

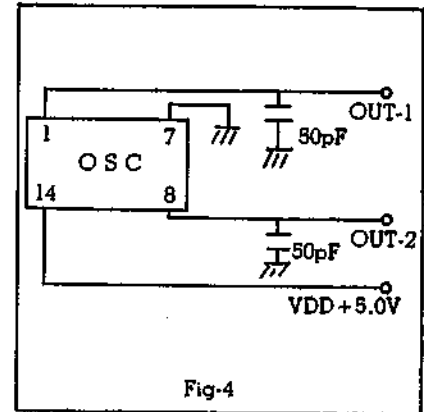

Fig-4

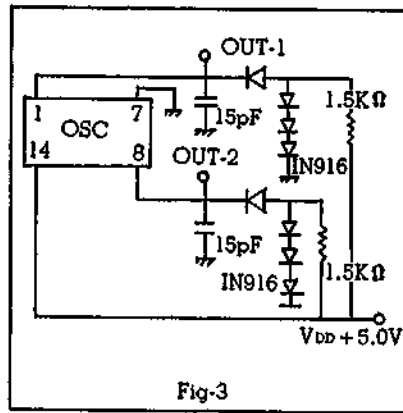
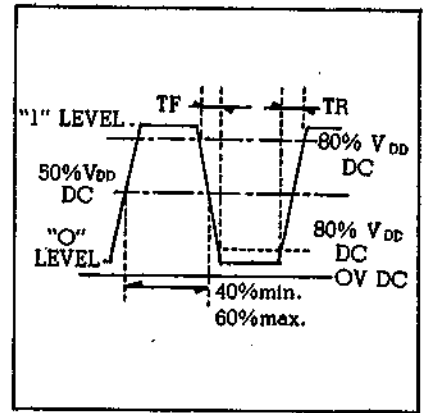

Fig-3



SPECIFICATIONS

Item	Specifications		
Output Frequency	8.0~32.0MHz 2 Output (Pin #1 8.0~32.0MHz) (Pin #8 8.0~32.0MHz)	Refer to Fig-1	
Frequency Tolerance	± 100ppm max.	Refer to Fig-2	
Operating Temp. Range	0 ~ + 70 °C		
Storage Temp. Range	- 55 ~ + 125 °C		
Out Put characteristics	"0" Level	+ 0.5V max.	Fig-3
	"1" Level	+ 4.0V min.	Fig-3
	Rise and Fall Time Fall	15ns max./20~80% VDD DC	Fig-4
	Output Load	50pF or 10LS TTL	
	Symmetry	40/60~60/40%/50% VDD DC	Fig-4
	Power Supply Voltage (VDD)	+ 5.0V ± 0.5V DC	
	Current Consumption	40mA max.	Fig-2