

ADC-SYSCLK: 8,3886Mhz(max) 4.194Mhz(norm)
 ADC-BCLK(max): ADC-SYSCLK/2
 LRCK: ADC-SYSCLK/256
 FS: ADC-SYSCLK/2048
 BCLK-GATE: ADC-SYSCLK/128
 MUX(A): ADC-SYSCLK/64
 PLL-IN-CLK: ADC-SYSCLK/2048 4096Hz(max) 2048Hz (norm)

	DATE	NAME	AD / COM	REV.: 1.0
DRAWN:				
CHECKED:		G. Raich		
PROJECT:	8CH AD-FRONTEND		DWG-NAME:	Sheet:
FILENAME:				

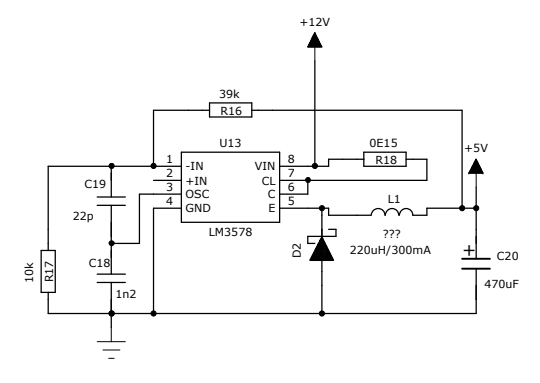
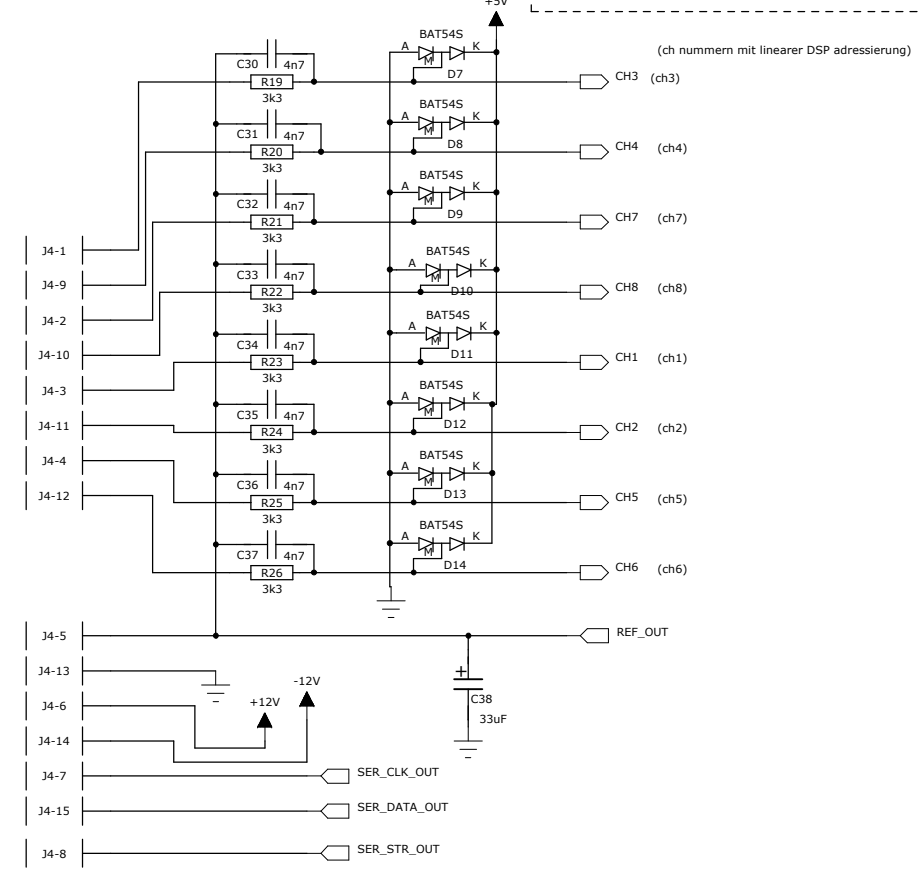
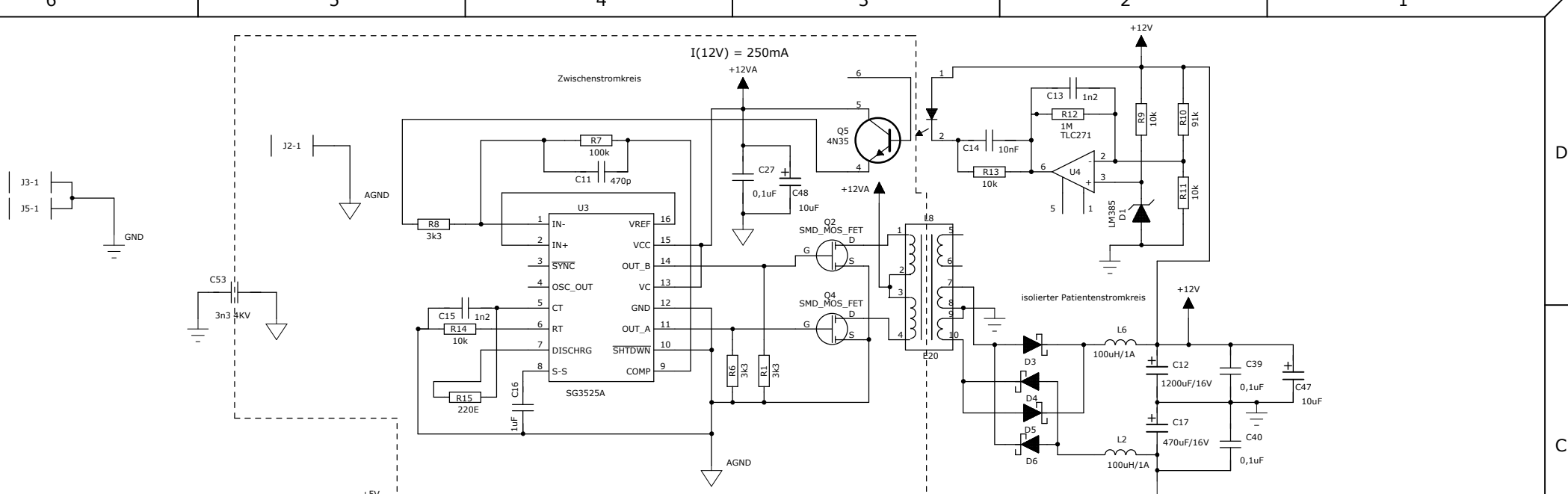

DATE	NAME	Supply	REV.: 1.0
DRAWN:	CHECKED: G. Raich		Sheet:
PROJECT: 8CH AD-FRONTEND	DWG-NAME:		
FILENAME:			